

Tesla Solar Inverter with Solar Shutdown Device

Tesla Solar Inverter completes the Tesla home solar system, converting DC power from solar to AC power for home consumption. Tesla's renowned expertise in power electronics has been combined with robust safety features and a simple installation process to produce an outstanding solar inverter that is compatible with both Solar Roof and traditional solar panels. Once installed, homeowners use the Tesla mobile app to manage their solar system and monitor energy consumption, resulting in a truly unique ecosystem experience.

KEY FEATURES

- Built on Powerwall technology for exceptional efficiency and reliability
- Wi-Fi, Ethernet, and cellular connectivity with easy over-the-air updates
- Designed to integrate with Tesla Powerwall and Tesla App
- 0.5% revenue-grade metering for Solar Renewable Energy Credit (SREC) programs included



Tesla Solar Inverter Technical Specifications

Electrical Specifications: Output (AC)	Model Number	1538000-xx-y
	Output (AC)	7.6 kW
	Nominal Power	7,600 W
	Maximum Apparent Power	7,680 VA at 240 V
	Maximum Continuous Current	32 A
	Breaker (Overcurrent Protection)	40 A
	Nominal Power Factor	1 - 0.9 (leading / lagging)
	THD (at Nominal Power)	<5%

Electrical Specifications: Input (DC)	MPPT	4
	Input Connectors per MPPT	1-2-1-2
	Maximum Input Voltage	600 VDC
	DC Input Voltage Range	60 - 550 VDC
	DC MPPT Voltage Range	60 - 480 VDC ¹
	Maximum Current per MPPT (I_{MP})	13 A ²
	Maximum Short Circuit Current per MPPT (I_{SC})	17 A ²

¹ Maximum current.

² Where the DC input current exceeds an MPPT rating, jumpers can be used to allow a single MPPT to intake additional DC current up to 26 A I_{MP} / 34 A I_{SC} .

Performance Specifications	Peak Efficiency	98.6% at 240 V
	CEC Efficiency	98.0% at 240 V
	Allowable DC/AC Ratio	1.7
	Customer Interface	Tesla Mobile App
	Internet Connectivity	Wi-Fi (2.4 GHz, 802.11 b/g/n), Ethernet, Cellular (LTE/4G) ³
	Revenue Grade Meter	Revenue Accurate (+/- 0.5%)
	AC Remote Metering Support	Wi-Fi (2.4 GHz, 802.11 b/g/n), RS-485
	Protections	Integrated arc fault circuit interrupter (AFCI), Rapid Shutdown
	Supported Grid Types	60 Hz, 240 V Split Phase

³ Cellular connectivity subject to network operator service coverage and signal strength.

Tesla Solar Inverter Technical Specifications

Mechanical Specifications

Dimensions

660 mm x 411 mm x 158 mm (26 in x 16 in x 6 in)

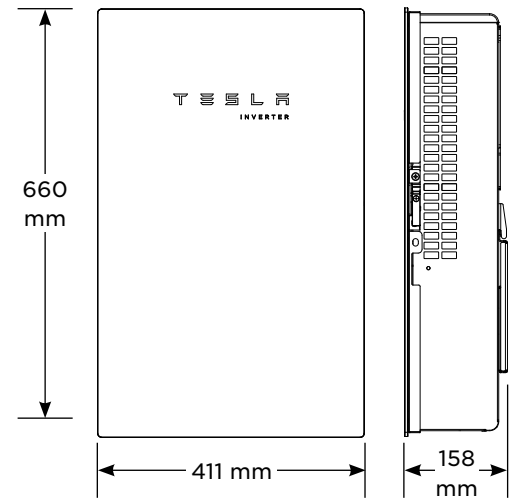

Weight

52 lb⁴

Mounting Options

Wall mount (bracket)

⁴ Door and bracket can be removed for a mounting weight of 37 lb.

Environmental Specifications

Operating Temperature

-30°C to 45°C (-22°F to 113°F)⁵

Operating Humidity (RH)

Up to 100%, condensing

Storage Temperature

-30°C to 70°C (-22°F to 158°F)

Maximum Elevation

3000 m (9843 ft)

Environment

Indoor and outdoor rated

Enclosure Rating

Type 3R

Ingress Rating

IP55 (Wiring compartment)

Pollution Rating

PD2 for power electronics and terminal wiring compartment, PD3 for all other components

Operating Noise @ 1 m

< 40 db(A) nominal, < 50 db(A) maximum

⁵ Performance may be de-rated to 6.2 kW at 240 V when operating at temperatures greater than 45°C.

Compliance Information

Grid Certifications

UL 1741, UL 1741 SA, UL 1741 SB, IEEE 1547-2018, IEEE 1547.1

Safety Certifications

UL 1741 PVRSS, UL 1699B, UL 1998 (US), UL 3741

Emissions

EN 61000-6-3 (Residential), FCC 47CFR15.109 (a)

Solar Shutdown Device 1 Technical Specifications

The Solar Shutdown Device is a Mid-Circuit Interrupter (MCI) and is part of the PV system rapid shutdown (RSD) function in accordance with Article 690 of the applicable NEC. When paired with Tesla Solar Inverter, solar array shutdown is initiated by any loss of AC power.

Electrical Specifications	Nominal Input DC Current Rating (I_{MP})	12 A
	Maximum Input Short Circuit Current (I_{SC})	19 A
	Maximum System Voltage (PVHCS)	600 V DC
RSD Module Performance	Maximum Number of Devices per String	5
	Control	Power Line Excitation
	Passive State	Normally Open
	Maximum Power Consumption	7 W
	Warranty	25 years
Environmental Specifications	Ambient Temperature	-40°C to 50°C (-40°F to 122°F)
	Storage Temperature	-30°C to 70°C (-22°F to 158°F)
	Enclosure Rating	NEMA 4X / IP65
Compliance Information	Certifications	UL 1741 PVRSE, UL 3741, PVRSA (Photovoltaic Rapid Shutdown Array)
	RSD Initiation Method	PV System AC Breaker or Switch
	Compatible Equipment	See Compatibility Table below

Mechanical Specifications	Model Number	MCI-1
	Electrical Connections	MC4 Connector
	Housing	Plastic
	Dimensions	125 mm x 150 mm x 22 mm (5 in x 6 in x 1 in)
	Weight	350 g (0.77 lb)
	Mounting Options	ZEP Home Run Clip
		M4 Screw (#10) M8 Bolt (5/16") Nail / Wood screw

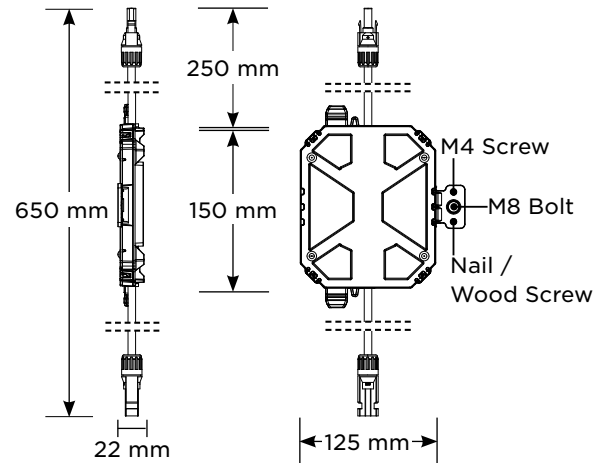

UL 3741 PV Hazard Control (and PVRSA) Compatibility

Tesla Solar Roof and Tesla/Zep ZS Arrays using the following modules are certified to UL 3741 and UL 1741 PVRSA when installed with Tesla Solar Inverter and Solar Shutdown Devices. See [Tesla Solar Inverter Rapid Shutdown: Module Selection Based on PV Hazard Control System Listing](#) for guidance on installing Tesla Solar Inverter and Solar Shutdown Devices with other modules.

Brand	Model	Required Solar Shutdown Devices
Tesla	Solar Roof V3	1 Solar Shutdown Device per 10 modules
Tesla	Tesla TxxxS (where xxx = 405 to 450 W, increments of 5)	1 Solar Shutdown Device per 3 modules ⁶
Tesla	Tesla TxxxH (where xxx = 395 to 415 W, increments of 5)	1 Solar Shutdown Device per 3 modules
Hanwha	Q.PEAK DUO BLK-G5 or Q.PEAK DUO BLK-G6+	1 Solar Shutdown Device per 3 modules

⁶ **Exception:** Tesla solar modules installed in locations where the max Voc for three modules at low design temperatures exceeds 165 V shall be limited to two modules between Solar Shutdown Devices.