

FASTENERS SOLD SEPARATELY

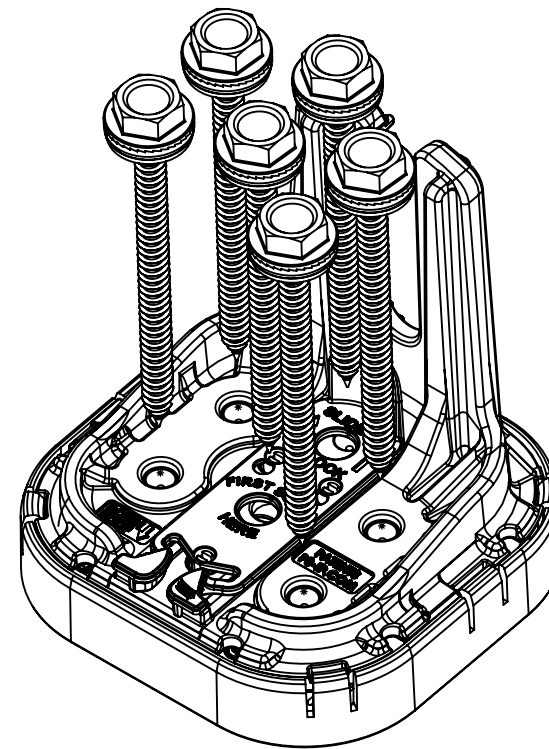

DECK ATTACH - 6 FASTENERS

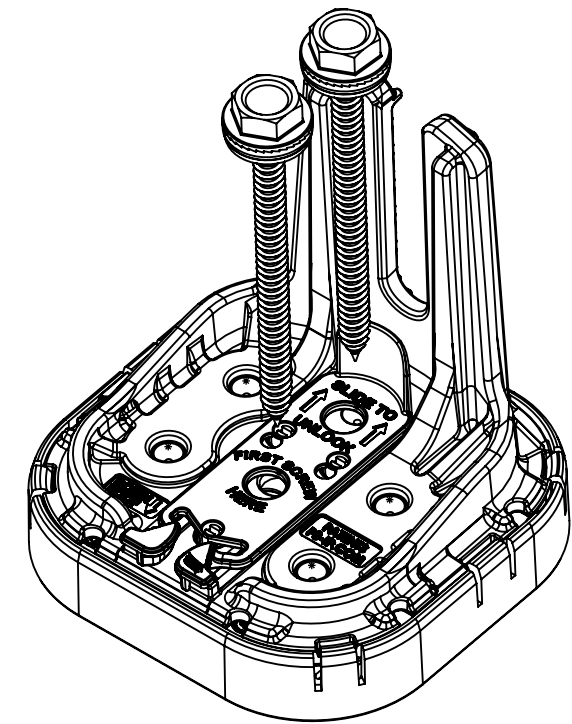

RAFTER ATTACH - 2 FASTENERS

PROPRIETARY AND CONFIDENTIAL
 THE INFORMATION CONTAINED IN THIS DRAWING IS THE SOLE PROPERTY OF PEGASUS SOLAR INC. ANY REPRODUCTION IN PART OR AS A WHOLE WITHOUT THE WRITTEN PERMISSION OF PEGASUS SOLAR INC IS PROHIBITED.

COMMENTS:

UNLESS OTHERWISE SPECIFIED: DIMENSIONS ARE IN MILLIMETERS

INTERPRET DRAWING PER ASME Y14.5-2009

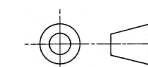

3RD ANGLE PROJECTION

TITLE:  **PEGASUS INSTAFLASH 2**

PART NUMBER: **PIF2-B0, PIF2-M0, PIF2-BDT, PIF2-MDT**

DRAWN: I. WOGAN

SIZE **B** REV **C**

CHECKED:

DATE: 20240523 SCALE: 1:1

SHEET 1 OF 1