



User Manual

Xtreme HV

A02 VERSION

E-mail: support@renonpower.com

Website: www.renonpower.com

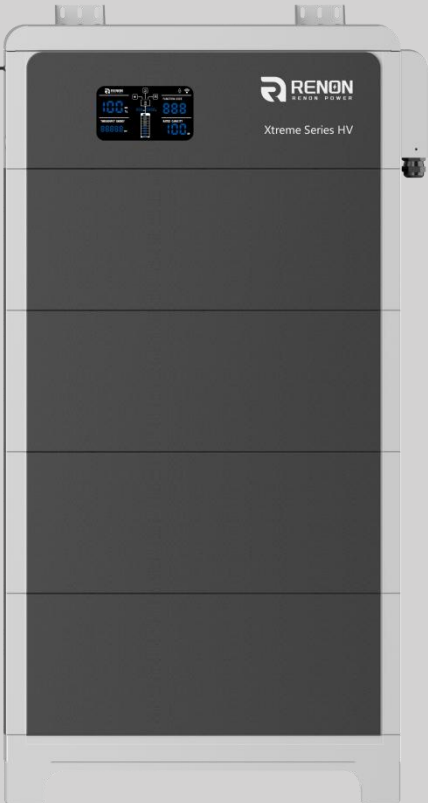

Renon Power Technology Inc.

© Renon Power Technology Inc.
All Rights Reserved Specifications are subject to change without notice.



Renon Power

We Care About Sustainability

With our own R&D team and automated production factory, we are dedicated to delivering innovative, reliable, and affordable energy storage solutions to customers globally.

At Renon, we believe that sustainable energy is the future. We are passionate about reducing carbon emissions and preserving our planet for future generations. That's why we invest heavily in research and development, leveraging the latest technologies to design and manufacture energy storage systems that are efficient, scalable, and adaptable.

Our products are designed to meet the needs of a wide range of applications, from residential and commercial buildings to industrial facilities and utility-scale projects. Whether you're looking to reduce your energy bills, increase your energy independence, or support your sustainability goals, Renon has the right solution for you.

Our commitment to quality and customer satisfaction is unwavering. We work closely with our clients to understand their unique needs and provide customized solutions that meet or exceed their expectations. We also provide comprehensive technical support, maintenance, and warranty services to ensure that our customers get the most out of their investment.

[JOIN US ON OUR MISSION TO MAKE RENEWABLE ENERGY WITHIN REACH.](#)

**PROVIDE INNOVATIVE,
RELIABLE, AND
AFFORDABLE ENERGY
STORAGE SOLUTIONS
TO CUSTOMERS**



Table of Contents

| | |
|--|----|
| 1. Safety Instructions | 6 |
| 1.1. General Safety Precautions | 6 |
| 1.2. Transportation and Storage Precautions | 6 |
| 1.3. Installation Precautions | 7 |
| 1.4. Usage Precautions | 8 |
| 1.5. Response to Emergency Situations | 8 |
| 1.6. Qualified Personnel | 9 |
| 2. Preparation before Installation | 10 |
| 2.1. Safe Handling Guide | 10 |
| 2.1.1. Familiarize Yourself with the Battery | 10 |
| 2.1.2. Precautions | 10 |
| 2.1.3. Tools | 10 |
| 2.1.4. Safety Gear | 11 |
| 2.2. System Premeasurement | 11 |
| 2.3. Installation location | 11 |
| 2.4. Package Items | 12 |
| 3. Installation | 15 |
| 3.1. Device Installation | 15 |
| 3.2. Connections of Cable and Power | 19 |
| 3.3. Parallel | 21 |
| 3.3.1. Two Batteries | 21 |
| 3.3.2. Multiple Batteries | 22 |
| 3.4. Power On | 22 |
| 4. Cloud Platform Configuration | 23 |
| 5. Battery Specifications | 31 |
| 5.1. Product Features | 31 |
| 5.2. Specifications | 32 |
| 5.3. Function Introduction | 33 |

| | |
|---|----|
| 5.3.1. Protection | 33 |
| 5.3.2. Forced Discharge | 33 |
| 5.3.3. Charging Self-Adaptation Control | 33 |
| 5.3.4. Emergency Stop | 33 |
| 5.4. Interface Information | 34 |
| 5.4.1. Inverter Dial Switch | 34 |
| 5.4.2. Address Dial Switch | 36 |
| 5.4.3. Function Dial Switch | 36 |
| 5.4.4. Parallel | 36 |
| 5.4.5. USB Port | 36 |
| 5.4.6. Dry Contact | 37 |
| 5.4.7. Inverter Communication Port (connector) | 37 |
| 5.4.8. Inverter Communication Port (RJ45) | 37 |
| 5.4.9. Debug Port | 38 |
| 5.4.10. Link A and Link B | 39 |
| 5.4.11. Power Positive & Negative | 39 |
| 5.4.12. Power Switch | 39 |
| 5.4.13. Active Switch | 39 |
| 5.4.14. On/Off | 39 |
| 5.4.15. WiFi Antenna | 39 |
| 5.4.16. Dial Code Switch | 40 |
| 5.5. Monitoring Screen | 42 |
| 5.5.1. LCD Screen Introduction | 42 |
| 5.5.2. SOC, SOH and Upgrading State | 42 |
| 5.5.3. Version and Accumulated Discharge Energy | 43 |
| 5.5.4. ESS status, Power, and Voltage | 43 |
| 5.5.5. Battery Operation Status | 43 |
| 5.6. Screen Display Code | 44 |
| 6. Troubleshooting & Maintenance | 47 |

| | |
|--------------------------------|----|
| 6.1. Regular Maintenance | 47 |
| 6.2. Troubleshooting | 47 |
| 6.3. Status Codes | 48 |
| 6.3.1. Warning Codes | 49 |
| 6.3.2. Error Codes | 51 |
| 6.3.3. Protection Codes | 54 |

1. Safety Instructions

For safety reasons, installer and user are responsible for familiarizing themselves with the contents of this document and all warnings before installation and usage.

1.1. General Safety Precautions

- Please carefully read this manual before any work is carried out on the product, and keep it located near the product for future reference.
- All installation and operation must comply with local electrical standards.
- Please ensure the electrical parameters of the product are compatible to related equipment.
- Do not open or dismantle the battery module. Electrolyte is very corrosive. In normal working conditions contact with the electrolyte is impossible. If the battery casing is damaged, do not touch the exposed electrolyte or powder because it is corrosive.
- The electronics inside the product are vulnerable to electrostatic discharge.
- Do not place items or tools on the product.
- Do not damage the product by dropping, deforming, impacting, or cutting.
- Keep the product away from liquid. Do not touch the product if liquid spills on it. There is a risk of electric shock.
- Do not expose the product to flammable or harsh chemicals or vapors.
- Do not paint any part of the product, include any internal or external components.
- Do not change any part of the product, especially the battery and cell.
- Besides connection under this manual, any other foreign object is prohibited from being inserted into any part of the product.
- The warranty claims are excluded for direct or indirect damage due to items above.
- Batteries must not be mixed with domestic or industrial waste.
- Batteries marked with the recycling symbol must be processed via a recognized recycling agency. By agreement, they may be returned to the manufacturer.

1.2. Transportation and Storage Precautions

- The batteries must be transported according to UN3480, they must be packed according to packaging requirements of Special Regulation 230 of IMDG CODE (40-20 Edition) for maritime transport, and P965 IA for air transport (SOC less than 30%). The original packaging complies with these instructions.

- If the product needs to be moved or repaired, the power must be cut off and completely shut down.
- The product must be transported in its original or equivalent package; the battery module must be placed at upright position.
- The modules are heavy. Ensure adequate and secure mounting and always use suitable handling equipment for transportation.
- If the product is in its package, use soft slings to avoid damage.
- Do not stand below the product when it is hoisted.
- During transportation, severe impact, extrusion, direct sunlight, and rain should be avoided.
- Store in a cool and dry place.
- Store the product in clean environment, free of dust, dirt, and debris.
- Store the product out of reach of children and animals.
- Don't store the battery under 50% SOC for over one month. This may result in permanent damage to the battery and void the warranty.
- During long term storage, it is required to charge the battery module every 3 months, and the SOC should be no less than 90%.

1.3. Installation Precautions

- Do not install the product in an airtight enclosure or in an area without ventilation.
- Do not install the product in living areas of dwelling units or in sleeping units other than within utility closets and storage or utility spaces.
- If the product is installed in a garage or carport, ensure there is adequate clearance from vehicles.
- While working on the product wear protective eyeglasses and clothing.
- Handle the battery wearing insulated gloves.
- Use insulated tools. Do not wear any metallic items such as watches, bracelets, etc.
- Turn-off related circuit breakers before and during the installation to avoid electric shock.
- Do not connect any AC conductors or photovoltaic conductors directly to the battery pack. These are only to be connected to the inverter.
- Wiring must be correct, do not mistake the positive and negative cables, and ensure no short circuit with the external device.
- Over-voltages or wrong wiring could damage the battery pack and cause combustion which can be extremely dangerous.
- Make sure the product is well grounded, and complies with local specifications. The recommended grounding resistance is less than 1Ω .

- Handle with care because Li-ion Battery is sensitive to mechanical shock.

1.4. Usage Precautions

- Before starting the system, the operator should strictly check the connection terminals to ensure that the terminals are firmly connected.
- If there's a circuit breaker between battery and inverter, the breaker is supposed to be on before powering on the battery.
- Do not open the product, connect, or disconnect any wires when it's working to avoid electric shock.
- Battery needs to be recharged within 12 hours after fully discharging.
- The default temperature range over which the battery can be discharged is -4°F (-20°C) to 122°F (50°C). Frequently discharging the battery in high or low temperature may deteriorate the performance and life of the battery pack.
- The default temperature range over which the battery can be charged is 32°F (0°C) to 122°F (50°C). Frequently charging the battery in high or low temperature may deteriorate the performance and life of the battery pack.
- Do not charge or discharge a damaged battery.
- Please contact the supplier within 24 hours if there is something abnormal.

1.5. Response to Emergency Situations

- Damaged batteries are dangerous and must be handled with extreme care. They are not suitable for use and may cause danger to people or property. If the battery pack appears to be damaged, place it in the original container and return it to an authorized dealer.
- If the battery pack is wet or submerged in water, do not allow anyone to touch the water, and then contact authorized dealer for technical support.
- In case of fire, use carbon dioxide, FM-200 or ABC dry powder fire extinguisher; if possible, move the battery pack to a safe area before it catches fire.
- If a user happens to be exposed to the internal materials of the battery cell due to damage on the outer casing, the following actions are recommended.
- In case of inhalation: Leave the contaminated area immediately and seek medical attention.
- In case of contact with eyes: Rinse eyes with running water for 15 minutes and seek medical attention.
- In case of contact with skin: Wash the contacted area with soap thoroughly and seek medical attention.

- In case of ingestion: Induce vomiting and seek medical attention.

1.6. Qualified Personnel

The installation guide part described herein is intended for use by skilled staff only. Skilled staff is defined as a trained and qualified electrician or installer who has all the following skills and experience:

- Knowledge of battery specification and properties.
- Knowledge of the installation of electrical devices.
- Knowledge of torsion and screwdrivers for different types of screws.
- Knowledge of local installation standards.
- Electrical license for battery installation required by the country or state.
- Knowledge of the dangers and risks associated with installing and using electrical devices and acceptable mitigation methods.
- Knowledge of and adherence to this guide and all safety precautions and best practices.

For safety reasons, installers are responsible for familiarizing themselves with the contents of this document and all warnings before performing installation and usage.

2. Preparation before Installation

2.1. Safe Handling Guide

2.1.1. Familiarize Yourself with the Battery

Be careful when unpacking the system. Every module of the product is heavy. Don't lift them with a pole. The weight of the modules can be found in the chapter "**Specifications**".

Familiarize yourself with the battery. The battery poles are located on the top and bottom sides of the battery module. It's designed of fast mounting and simplicity, no need to recognize the positive and negative poles, but take care of them especially the bottom one.

2.1.2. Precautions

Before installation, be sure to read the contents in chapter "**Safety Precautions**", which is related to the operation safety of installation personnel, please pay attention to it.

2.1.3. Tools

The following tools are required to install the product:



Cordless Drill

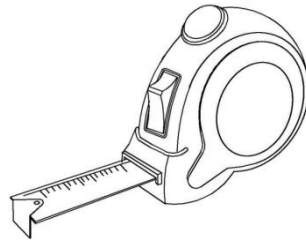

Measuring Tape



Pencil or Marker

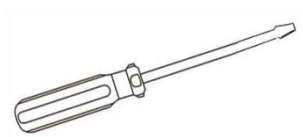

Flathead Screwdriver

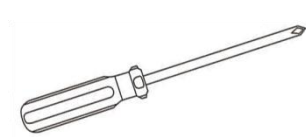

Phillips Screwdriver

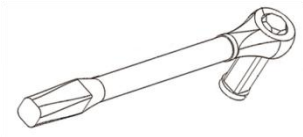

Torque Wrench

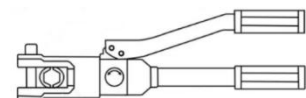

Hydraulic Clamp

Use properly insulated tools to prevent accidental electric shock or short circuits. If insulated tools are not available, cover the entire exposed metal surfaces of the available tools, except their tips, with electrical tape.

2.1.4. Safety Gear

It is recommended to wear the following safety gear when dealing with the product:



Insulated gloves

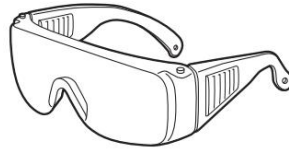

Safety goggles



Safety shoes

2.2. System Premeasurement

The battery requires adequate clearance for installation, cabling and airflow. The minimum clearance for system configuration is given below. The cable connected between battery pack and inverter should be in accordance with the installation guide or manual of the inverter.

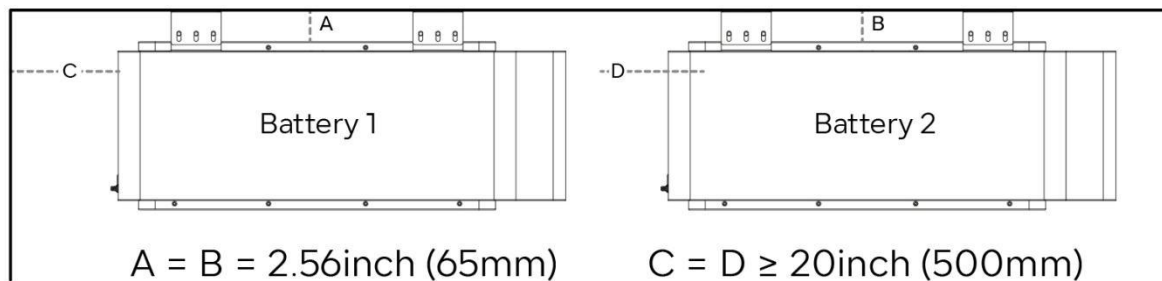

Figure 2.2.1. System clearance

2.3. Installation location

Make sure that the installation location meets the following conditions:

- The floor is flat and level.
- The surface of the wall is smooth and perpendicular to the ground, which can bear the weight.
- The area is completely water proof.
- The area shall avoid direct sunlight.
- There are no flammable or explosive materials.







- The distance from heat source is more than 80 in (2m).
- The ambient temperature should not exceed the range of battery usage temperature.
- The humidity should not exceed the range of battery usage humidity.
- There is minimal dust and dirt in the area.
- Avoid installation in an area confined or with high salinity.
- Do not install outside directly.
- Do not place in an area accessible to children or pets.











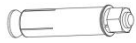

2.4. Package Items

After receiving the product, please unpack the boxes, and check product and packing list first. If product is damaged or lacks parts, please contact the local retailer.



Here is the Xtreme HV Packing List:

(1) Main controller:

| No. | Item | Specification | Qty | Usage | Diagram |
|-----|--------------------|---|-----|--|---|
| 1 | Main controller | 32.3*10.6*9inches /820*270*229mm | 1 | Controller of the battery cluster |  |
| 2 | Base | 30.5*9.4*4.8inches /775*238*121.5mm | 1 | Bottom base of the battery cluster |  |
| 3 | Mounting bracket A | 3.1*2.2*2.2inches /80*55*55mm | 2 | Mounted at the rear of the controller, used to stabilize the cluster |  |
| 4 | Mounting bracket B | 3.1*1.6*0.9inches /80*40*22mm | 2 | Combine the mounting bracket A to wall, used to stabilize the cluster |  |
| 5 | Screw | Stainless steel M4*12 triple combination | 8 | Fasten mounting bracket A to controller, fix the side panel connector to the bottom base |  |
| 6 | Screw | Stainless steel M6*16 triple combination | 6 | Fasten mounting bracket B to A |  |
| 7 | Screw | Stainless steel M4*10 | 8 | Side plate fixing screws |  |

| | | | | | |
|----|--|---|---|--|---|
| 8 | Screw | Plastic expansion screw 10*60 | 6 | Fasten mounting bracket B to wall |  |
| 9 | Screw | Stainless steel expansion screw M8*80 | 4 | Fasten base to floor |  |
| 10 | WIFI antenna | 2.4GHz L-type | 1 | Connect with internet |  |
| 11 | User manual | Xtreme HV series | 1 | User manual |  |
| 12 | Positive power cable (customizable) | Red, 6AWG, with RNB14-6S terminals on both side, 1.5m | 1 | Connect positive pole of battery and inverter |  |
| 13 | Negative power cable (customizable) | Black, 6AWG, with RNB14-6S terminals on both side, 1.5m | 1 | Connect negative pole of battery and inverter |  |
| 14 | Communication cable(optional) | Standard RJ45 network cable, 200mm*1, 2000mm*1 | 2 | Connect the communication pole of battery and inverter |  |
| 15 | Pin order select box (optional) | 3.3*1.0*0.9inches /85*26*22mm | 1 | Set the pin order of the communication cable of battery and inverter, cooperate with 2 standard network cable |  |
| 16 | Allen key | M4 | 1 | Tighten the screws on the side cover of the main controller |  |
| 17 | Pedestal layer | 163x15, SPCC, T=2 | 2 | Under aluminum side panel |  |
| 18 | Main control layer | 163x26, Aluminum, T=4.5 | 2 | Main control sides |  |
| 19 | Communication cable | RJ45, L=2m | 1 | Parallel communication cable |  |
| 20 | OT terminal | RNB14-6 | 2 | Use for power cable |  |

(2) Battery module:

| No. | Item | Specification | Qty | Usage | Diagram |
|-----|----------------|--|-----|----------------------------|---|
| 1 | Battery module | 30.5*10.6*11inches /775*270*279mm | 1 | Storage of cells |  |
| 2 | Screw | M4*10 screws with collar | 4 | Side plate fixing screws |  |
| 3 | Side plate | 10.4*6.5*0.2inches /264.8*164*4.5mm | 2 | To fix the battery modules |  |

3. Installation

3.1. Device Installation

1) Preparation of main control: Fastened 2 mounting brackets A to the top back of the controller and screw those properly.

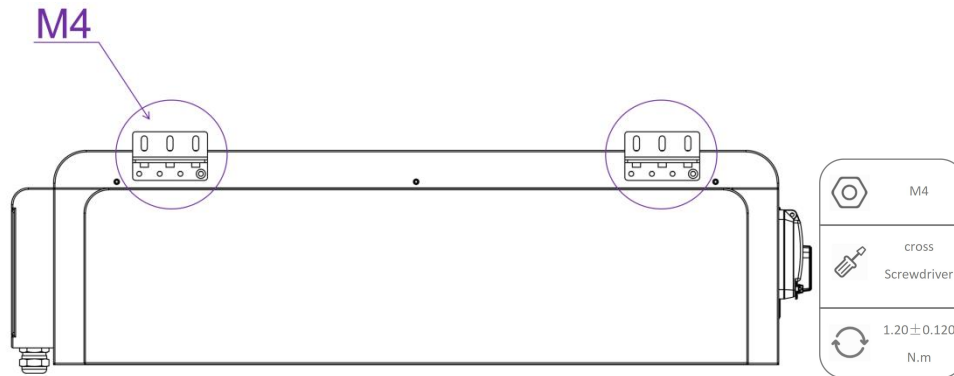

Figure 3.1.1. Fasten the mounting bracket A

Preparation of the module: Fastened 2 mounting brackets B to mounting bracket A and screw those properly.

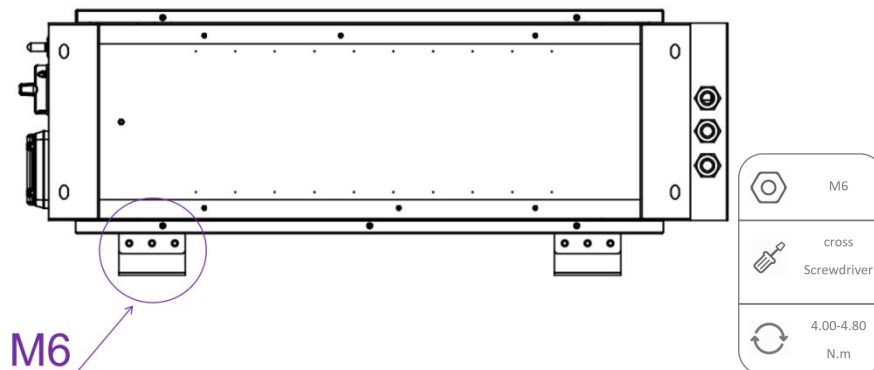

Figure 3.1.2. Fasten the mounting bracket B

2) Place the base on the floor be close to the wall 2.08 in (53mm), the connector of the base should be placed at the left side.

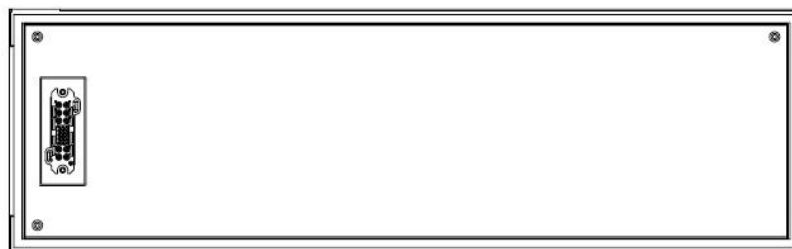

Figure 3.1.3. Put the base on the floor

3) Fasten the 4 mounting holes of the base on the floor in a stable condition.

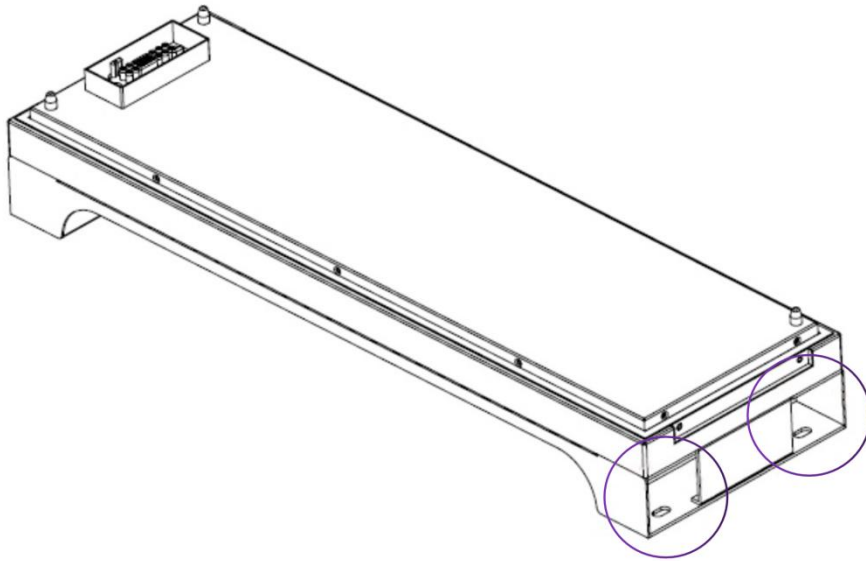

Figure 3.1.4. Mounting holes of the base

4) Stack up the battery modules, and then place the main control on the top finally. There are protective patches on both top and bottom of the connectors, please tear off them before stack.

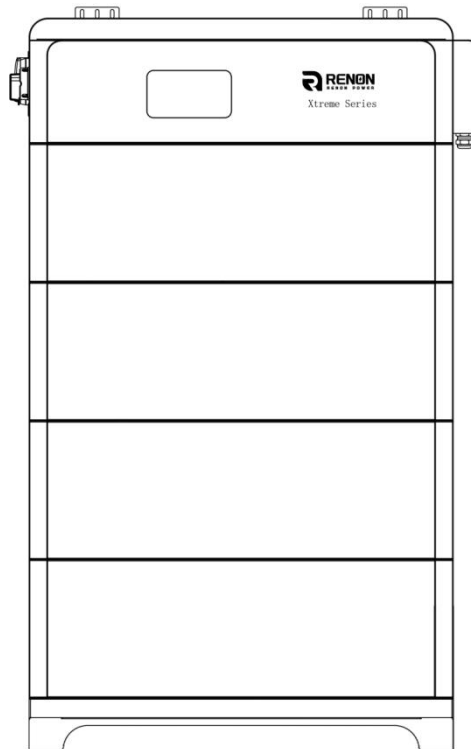

Figure 3.1.5. Stacked product (4 modules)

5) Fasten the 6 mounting holes of the mounting bracket B on the wall in a stable condition.

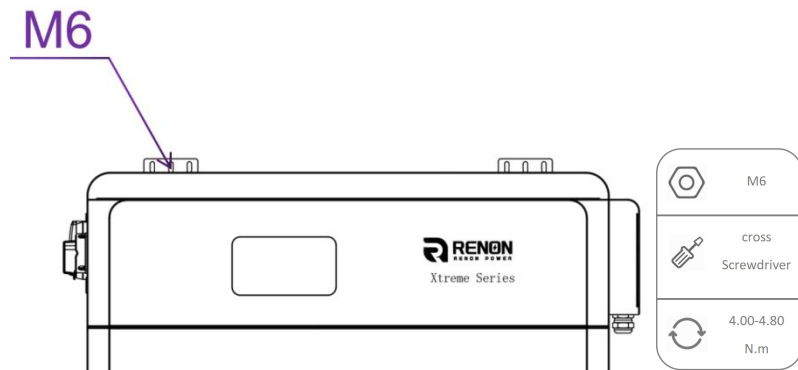

Figure 3.1.6. Mounting battery to the wall

6) Install the pedestal layer between the bottom battery module and the base.

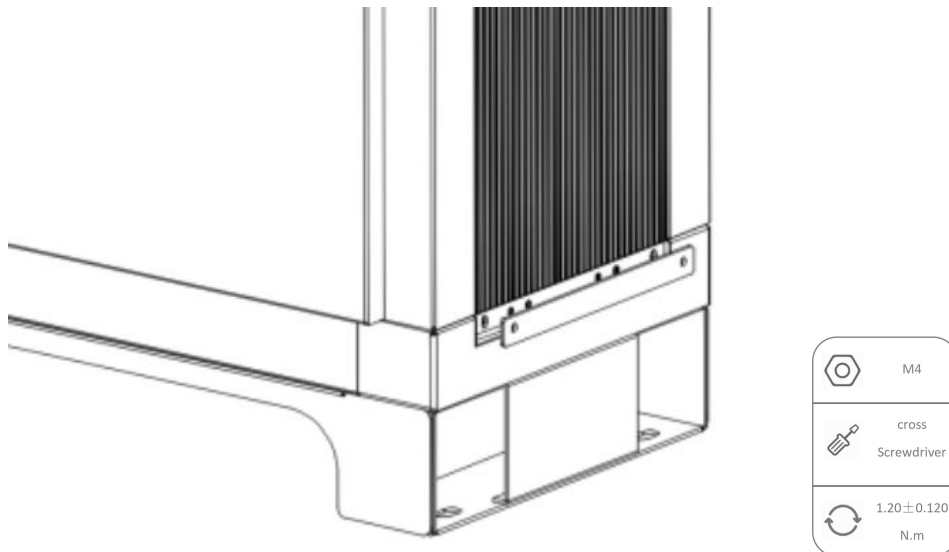

Figure 3.1.7. Mounting side panel connector

7) Screw the side plate to the side of each battery modules and make sure it is attached and screw properly.

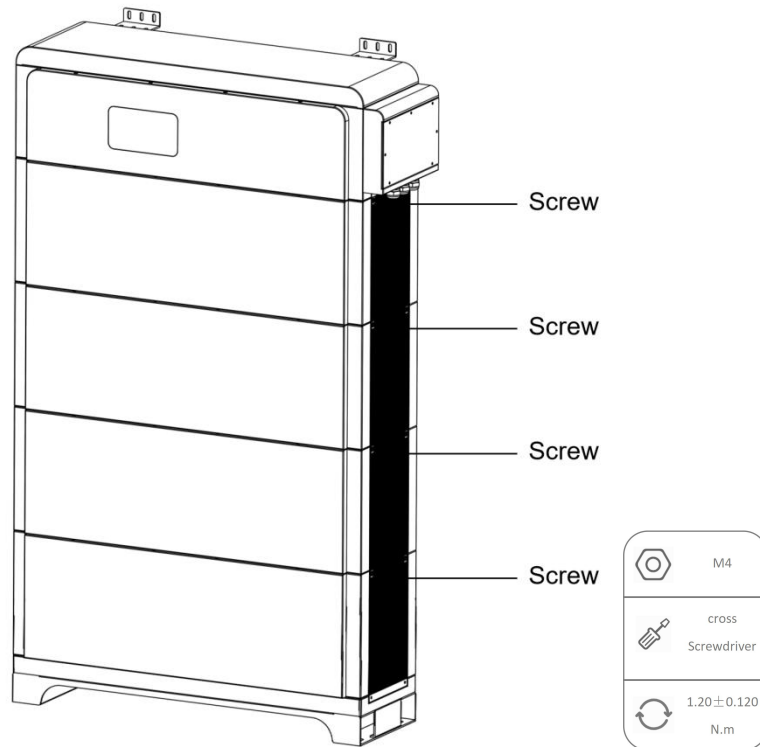

Figure 3.1.8. Install diagram of the mounting brackets

8) Install WiFi antenna

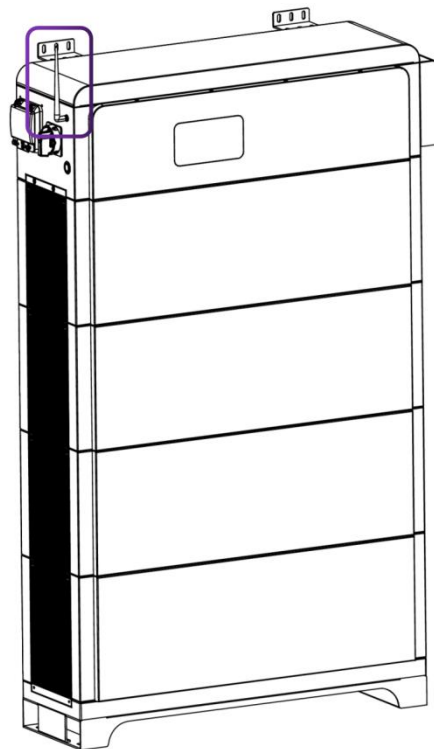

Figure 3.1.9. Install WiFi antenna

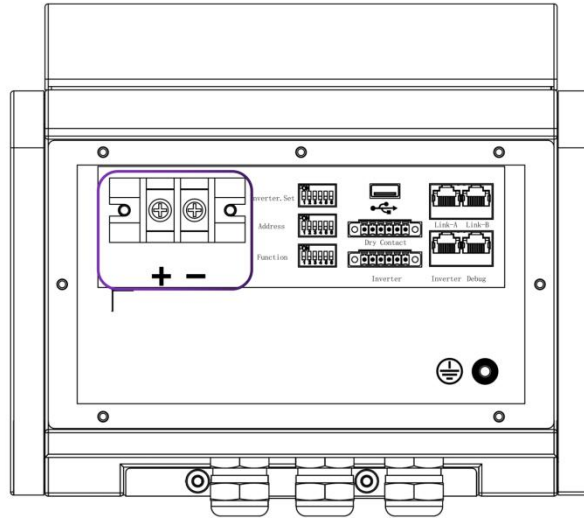

Figure 3.2.3. Positive & Negative

4) Communication cable connection

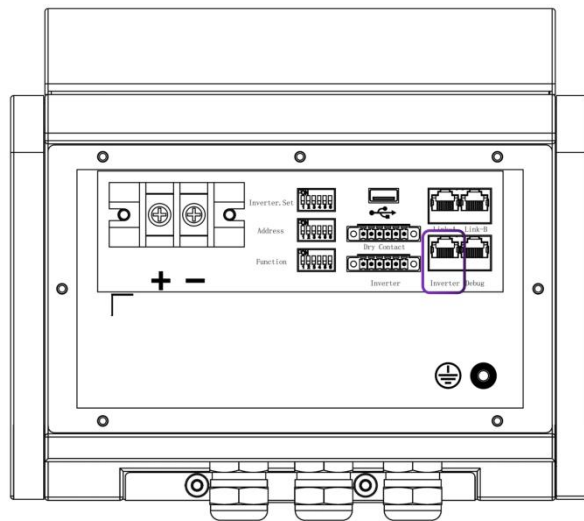

Figure 3.2.4. Inverter port

5) Dial code setting

Step 1: Please refer to the 5.3.1 Inverter Dial Switch for inverter configuration.

Step 2: Please refer to the 5.3.2 Address Dial Switch for address configuration.

Step 3: Please refer to the 5.3.3 Function Dial Switch for function configuration.

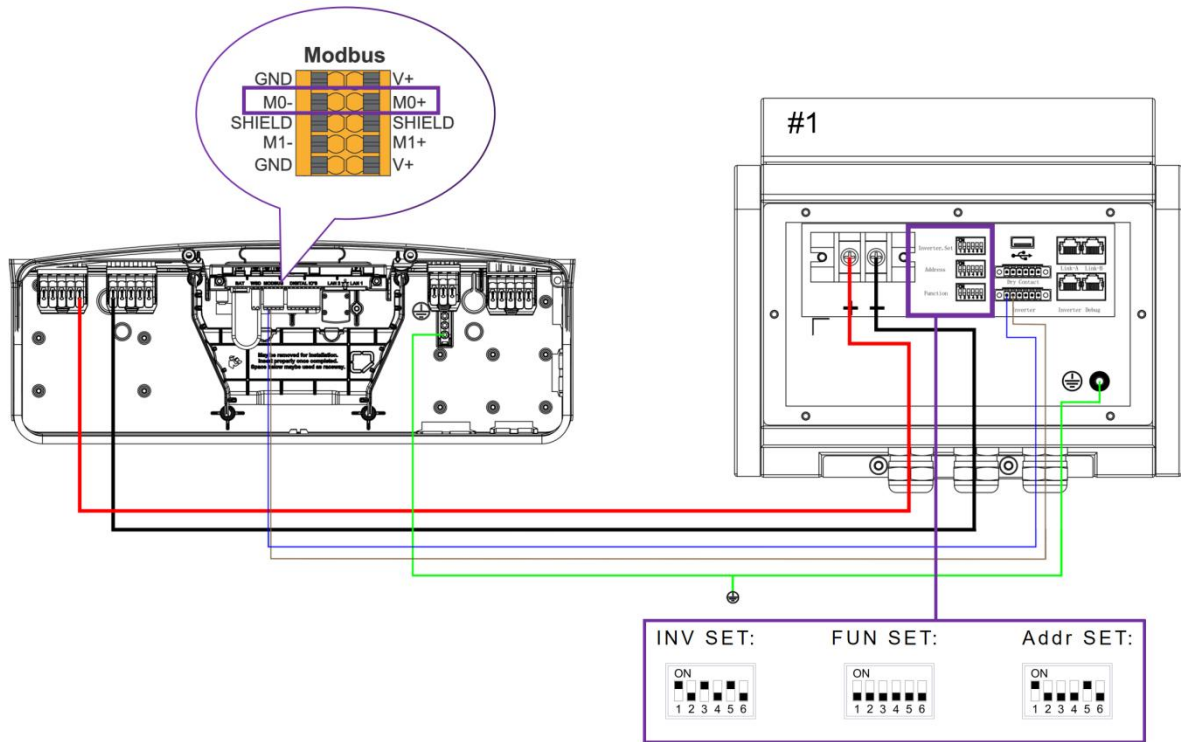

Figure 3.2.5. Dial code setting

3.3. Parallel

3.3.1. Two Batteries

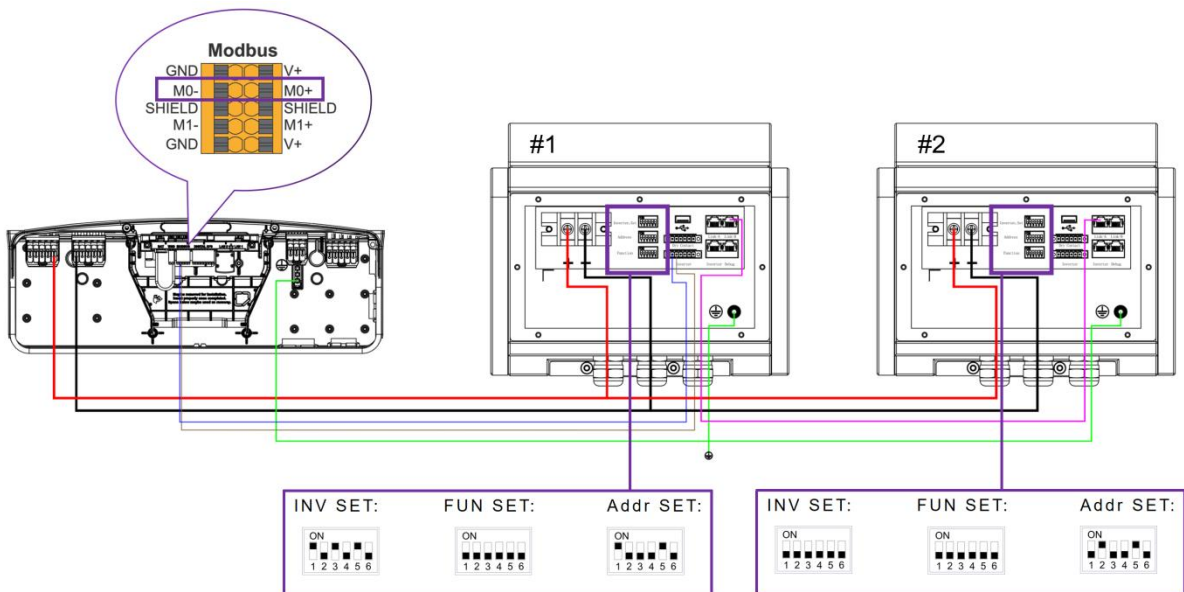

Figure 3.3.1. Two batteries in parallel

3.3.2. Multiple Batteries

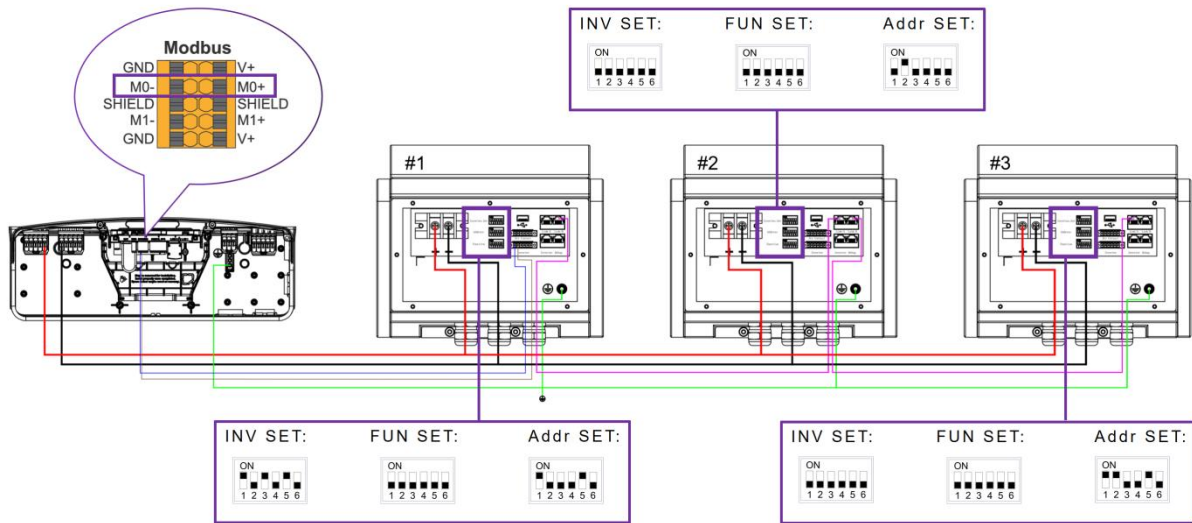

Figure 3.3.2. Multiple batteries in parallel

3.4. Power On

Please turn on the DC breaker of the inverter if it has one, then turn on the power switch, rotate the active switch to the “ON” position, press the power button, wait for the beeper sound occurred, and then rotate the active switch back to the “OFF” position.

| No. | Operation |
|-----|---------------------------------------|
| 1 | Turn on the power switch. |
| 2 | Rotate the active switch to the “ON”. |
| 3 | Press the power button. |
| 4 | Rotate the active back to the “OFF”. |

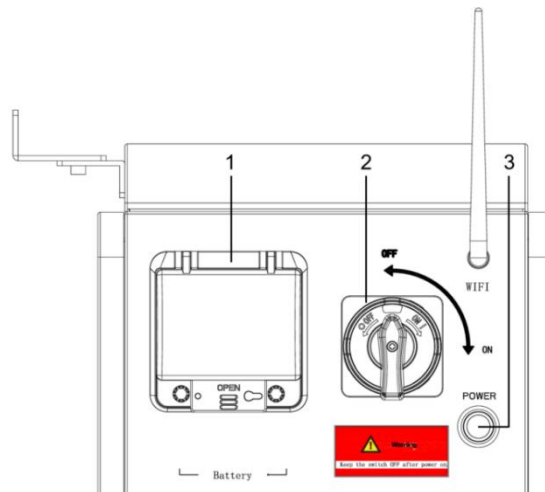

Figure 3.4.1. Side of the battery

4. Cloud Platform Configuration

1) Download App

Download and install Renon app from Google play or App Store by searching “Renon Smart”.



Figure 4.1.1. Install Renon App



Figure 4.1.2. Android QR code



Figure 4.1.3. IOS QR code



2) Register

For new account registration, please retrieve the Registration Code from your installer. Existing users may log in directly, while new users must create an account.

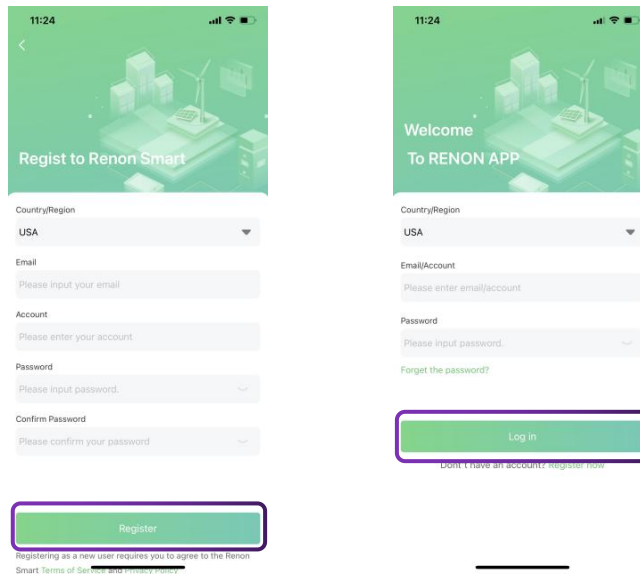

Figure 4.1.4. Register & Log in

3) Log in

This is a general user account.

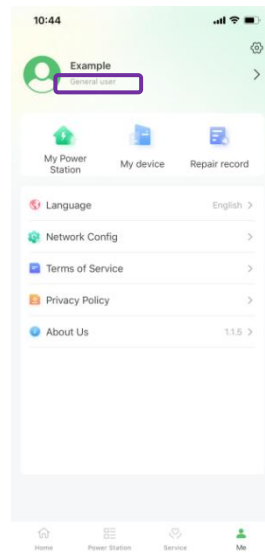

Figure 4.1.5. General user

4) Binding

Method 1:

a. Distribution

To register as an end user, scan the binding QR code provided by your installer, then request device assignment to your account.

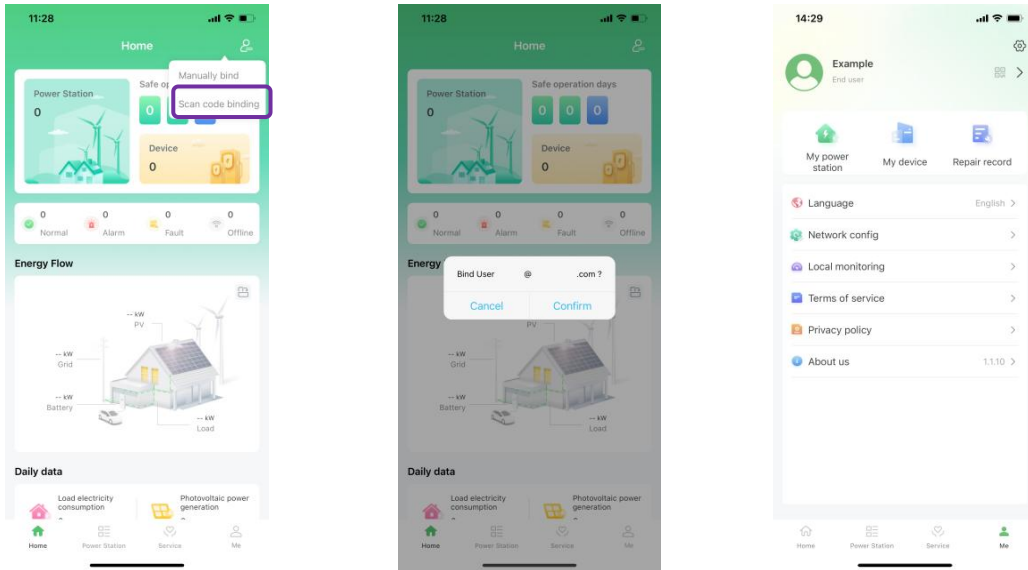

Figure 4.1.6. Scan upper-level account, Confirm binding & Become end user

b. Scan QR code

Select "Scan code binding" and scan the QR code using your device camera. Contact the installer if unsuccessful.

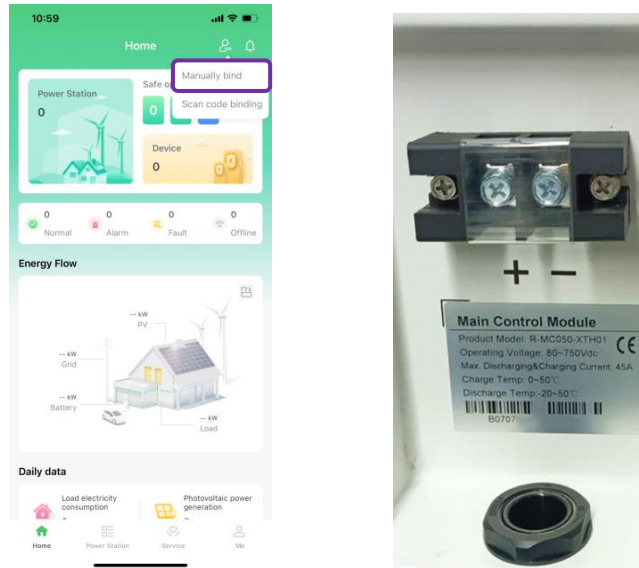

Figure 4.1.7. Scanning QR code

Method 2:

Click "My device" to enter the "Add a device" page, scan the QR code as illustrated, then select a upper-level account to complete binding.

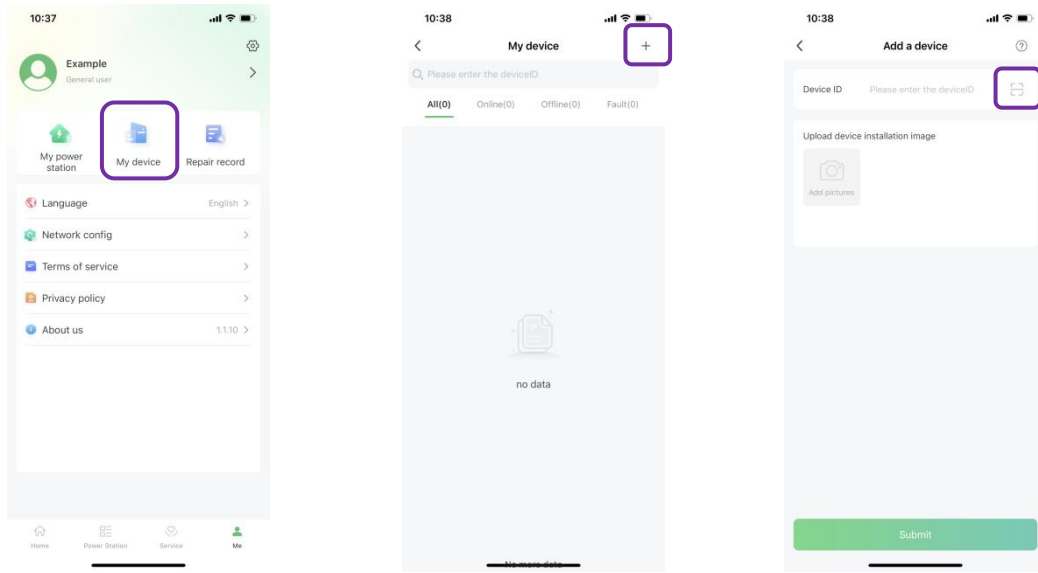

Figure 4.1.8. My device, add & scanning

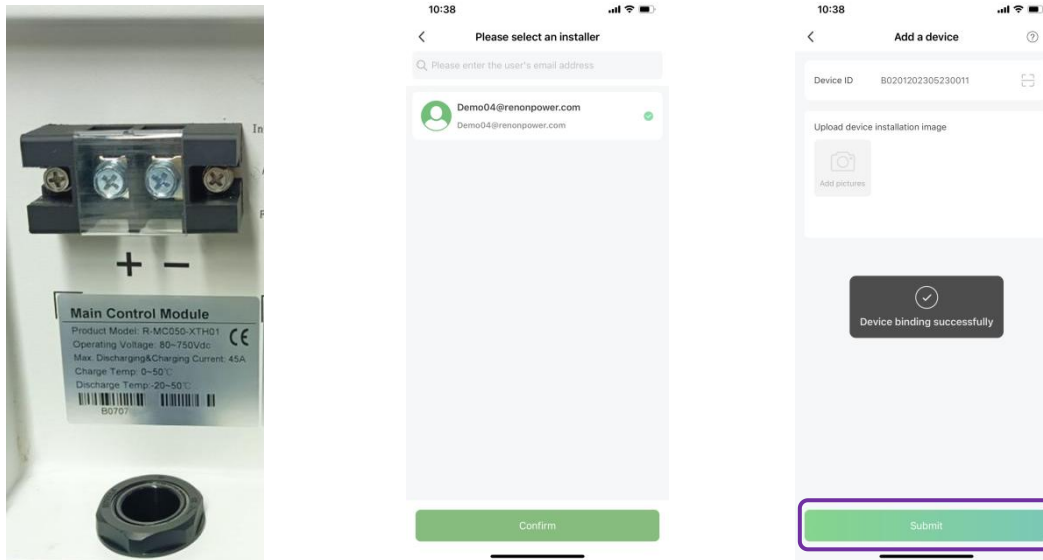

Figure 4.1.9. QR code, upper-level account & binding successfully

If the above methods are not successful, please contact Renon, email address: support@renon-usa.com, Renon Power Support: +1 (833) 736-6687. Be sure to write your account name/email address and device serial number clearly.

5) WiFi configuration

Set the inverter dial code to 63 (111111) as shown below before WiFi configuration.

Note: In a system with multiple batteries operating in parallel, you only need to configure the master battery unit (set to Address 1). Once configured, all other units will automatically retrieve network settings and connect seamlessly without manual intervention.

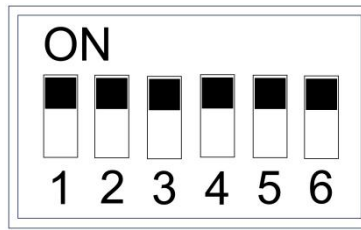

Turn to the “Me” page, click Network Configuration, then click Bluetooth, followed by WiFi configuration.

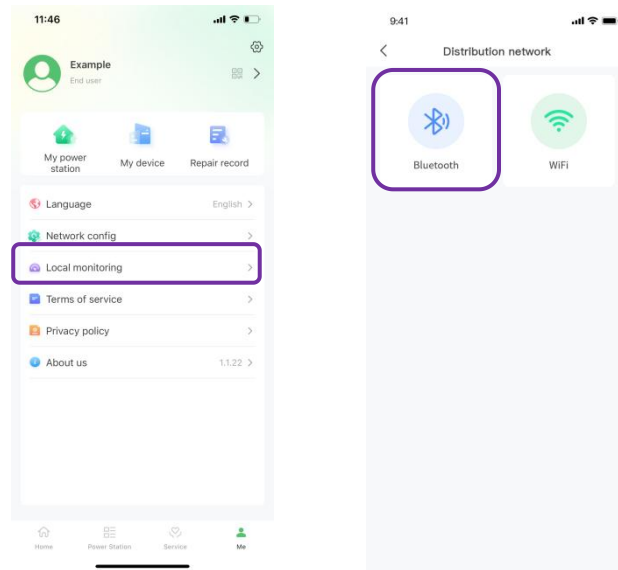

Figure 4.1.10. Bluetooth network setting

Enable Bluetooth on your mobile device, then select the detected device to access its Bluetooth network configuration page

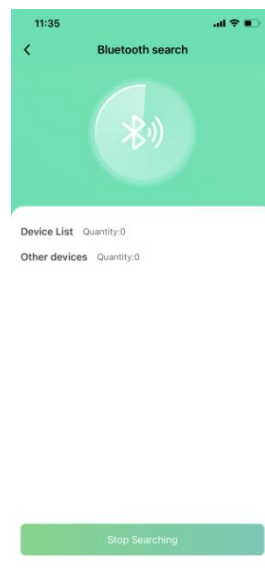

Figure 4.1.11. Connect battery Bluetooth

Enter your private WiFi credentials (SSID and password) to connect the master controller.

Note: Devices assigned to end users will auto-populate the authentication key.

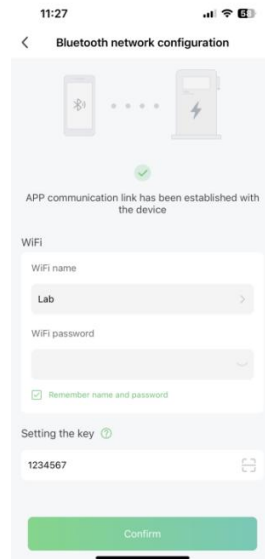

Figure 4.1.12. Connecting private WiFi

6) Create a power station

Navigate to the Power Station page on the app, create a new station by setting its name, type, pricing, superior view, address, and uploading station images.

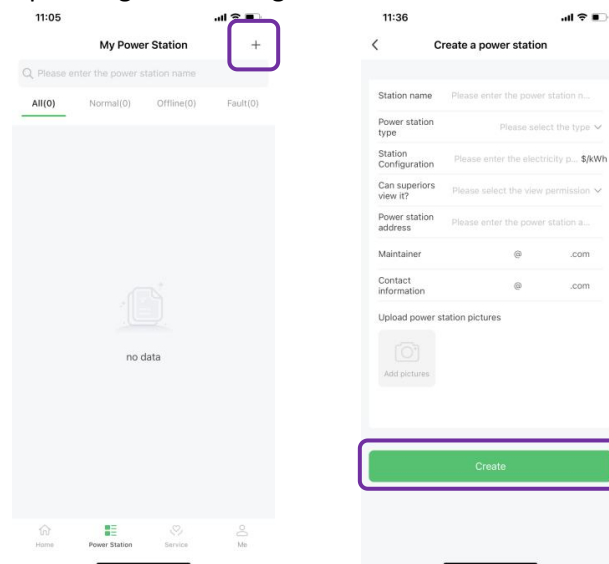

Figure 4.1.13. Create a new power station

After successful power station creation, select the newly created station to view its details, then tap "+" on the Binding Device page to add your desired device.

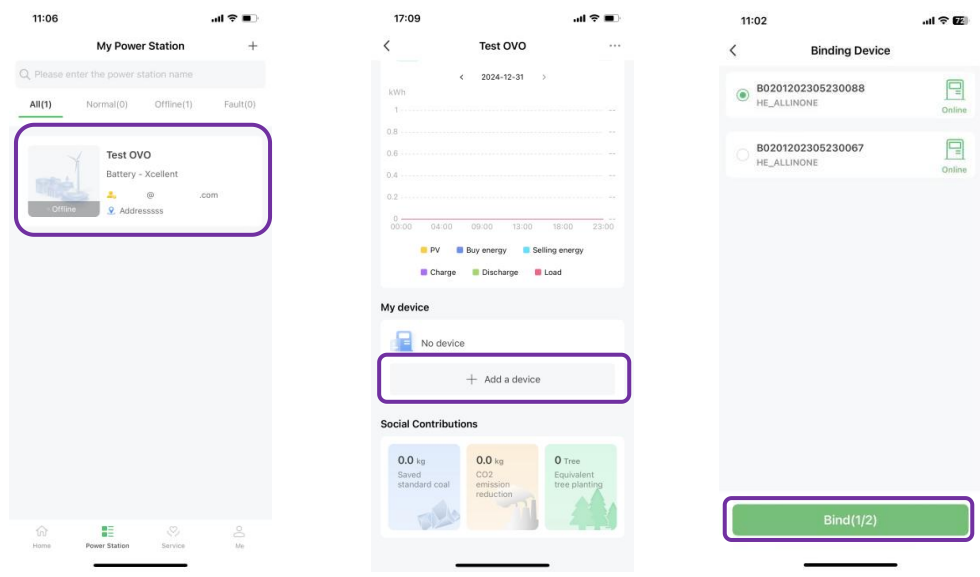

Figure 4.1.14. Manage your power station & Confirm your device

The device can be managed both through the app and the web portal (contact your installer for the website URL).



Figure 4.1.15. Manage your device

Once WiFi is connected, the device enables real-time monitoring of operational status, instantaneous power, and energy consumption (daily/cumulative) via the network platform or mobile app, while also supporting remote parameter configuration.

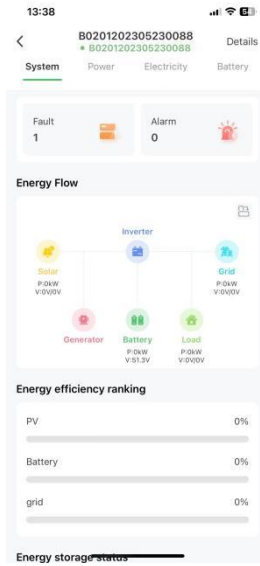

Figure 4.1.16. Monitoring device

Set the inverter dial code to match the inverter brand after WiFi configuration is complete (Please refer to the chapter **5.3.1 Inverter Dial Switch**).

5. Battery Specifications

The Xtreme HV series is a lithium iron phosphate (LFP) battery-based energy storage product developed and produced by RENON, it can supply reliable power for nearly all kinds of household appliances and equipment.

The Xtreme HV series consists of a main controller and several battery modules, each battery module has a battery information collection unit, which can monitor cells information including voltage and temperature. The main controller can sense the total voltage and current, communicate with all battery modules, manage and protect the battery.

The Xtreme HV series is very easy to install, and has a well-designed exterior suitable for indoor use.

Supports up to 6 battery modules to extend the energy of a single stack.

5.1. Product Features

- The whole product is non-toxic, pollution-free and environment-friendly.
- The battery chemistry is made from LiFePO₄ with safety, performance, and a long cycle life.
- The battery is small in volume, has plug & play embedded design module, and is easy to install and maintain.
- Working temperature range is between -4°F and 122°F (-20°C to 50°C) with excellent discharge performance.
- The battery management system (BMS) has protection functions for over-discharge, over-charge, over-current, and high/low temperature.
- The battery can self-discharge up to 3 months without charging and offers excellent performance of shallow charge and discharge.
- The system can automatically manage battery charge and discharge state and save energy costs with various automation options.

5.2. Specifications

| Item | R-XH096021 (-H) | R-XH014031 (-H) | R-XH019041 (-H) |
|--|---|---------------------------------|---------------------------------|
| Controller Model | R-MC050-XTH01(-H) | | |
| Battery Module Model | R-EM096050-XTH01 (-H) | | |
| Battery Chemistry | LiFePO4 | | |
| Module Quantity | 2 | 3 | 4 |
| Nominal Energy (kWh) | 9.6 | 14.4 | 19.2 |
| Nominal Capacity (Ah) | 50 | | |
| Max. Charging Current (A) | 45 | | |
| Max. Discharging Current (A) | 48 | | |
| Nominal Voltage (V) | 192 | 288 | 384 |
| Recommend Charging Voltage (V) | 213 | 319.5 | 426 |
| Discharge Cut-off Voltage (V) | 162 | 243 | 324 |
| Heating Film Resistance (Ω) | 56 per module (-H model only) | | |
| Heating Start Temperature ($^{\circ}$ F/ $^{\circ}$ C) | Reserved | | |
| Operation Temperature ($^{\circ}$ F/ $^{\circ}$ C) | Discharge: -4~122 / -20~50 Charge: 32~122 / 0~50 | | |
| Safety Function | Over-charge, Over-discharge, Over-current, Low/High-temperature, Short-circuit Protections | | |
| Communication | RS485/CAN/Wi-Fi | | |
| Weight (lbs/kg) (Approx.) | 331/150 | 460/208.5 | 589/267 |
| Physical Dimensions (inches/mm) (W*D*H) | 32.3*10.6*32.6 /820*270*829 | 32.3*10.6*42.6 /820*270*1082 | 32.3*10.6*52.5 /820*270*1334 |
| Level of Protection | IP65 | | |
| Altitude | \leq 4000m | | |

Note: -H indicates that this product contains a heating film and has a heating film function.

5.3. Function Introduction

5.3.1. Protection

The battery system is equipped with comprehensive protection features, including but not limited to overcharge/overdischarge protection, high/low temperature protection during charging/discharging, and overcurrent protection during charging/discharging, ensuring the safety and stability of the battery under various usage conditions.

5.3.2. Forced Discharge

When the system enters sleep mode due to undervoltage, users can manually activate the forced discharge mode by pressing the power button. Additionally, the system will automatically wake up at scheduled intervals to enter forced discharge mode, thereby activating the charger or inverter (the inverter requires grid connection) to provide necessary supplemental charging to the battery, ensuring its continued availability.

5.3.3. Charging Self-Adaptation Control

The system will automatically reduce charging power when the battery is in low/high temperature conditions or low/high SOC.

5.3.4. Emergency Stop

The first battery (Address 1)'s Dry Contact port (Pins 5-6) can be connected to the normally open (NO) contacts of an external emergency stop button. When activated, this will disconnect all battery outputs.

When multiple batteries are connected in parallel, the ESS disconnect only needs to be connected to the master battery.

If the inverter is equipped with Rapid Shutdown (RSD) capabilities, the emergency stop feature can initiate this function. It is recommended to check with the local Authority Having Jurisdiction (AHJ) and the National Electrical Code (NEC) for compliance.

5.4. Interface Information

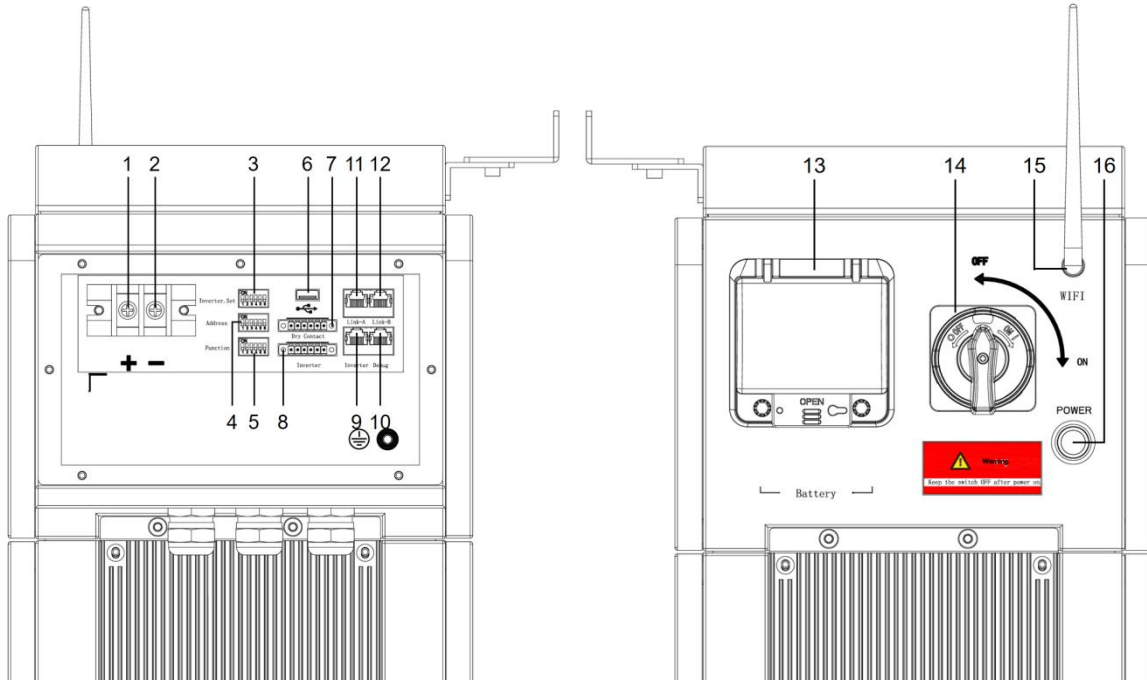

Figure 5.3.1. Interface definition of Controller module

| No. | Instructions | No. | Instructions |
|-----|---|-----|------------------------------------|
| 1 | Power Positive | 9 | Inverter Communication Port (RJ45) |
| 2 | Power Negative | 10 | Debug Port |
| 3 | Inverter Dial Switch | 11 | Link A |
| 4 | Address Dial Switch | 12 | Link B |
| 5 | Function Dial Switch | 13 | Power Switch |
| 6 | USB Port for Upgrade | 14 | Active Switch |
| 7 | Dry Contact | 15 | WiFi Antenna |
| 8 | Inverter Communication Port (connector) | 16 | On/Off |

5.4.1. Inverter Dial Switch

Code 0 ~ 20 of this Dial Switch are used to match which brand of inverter is using.





The definitions of code 0 ~ 20 are shown as below table.

| Code | Dial Switch Position | Brand | Logo |
|------|---|------------|---|
| 0 |  | Renon |  |
| 2 |  | Sol-Ark |  |
| 4 |  | Sermatec |  |
| 5 |  | Invt |  |
| 6 |  | ThinkPower |  |
| 8 |  | Deye |  |
| 9 |  | ATESS |  |
| 10 |  | Solis |  |
| 11 |  | Growatt |  |
| 13 |  | MEGAREVO |  |
| 14 |  | Sofar |  |
| 15 |  | Renac |  |
| 17 |  | AFORE |  |
| 18 |  | SINENG |  |
| 20 |  | Solinteg |  |
| 21 |  | Fronius |  |

5.4.2. Address Dial Switch

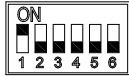
Use this Dial Switch to set the address of master controller and then turn on to activate the system.

The illustration of dialing as shown below:

| Code | Dial Switch Position | Definition |
|------|---|--|
| 1 |  | Set as Cluster 1 (communicate with inverter by this cluster) |
| 2 |  | Set as Cluster 2 |
| 3 |  | Set as Cluster 3 |
| 4 |  | Set as Cluster 4 |

5.4.3. Function Dial Switch







Use this dial switch to match the communication impedance:

| Code | Dial Code Switch Position | Definition |
|------|---|-----------------------------|
| 0 |  | When used as single cluster |

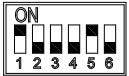
5.4.4. Parallel

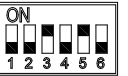
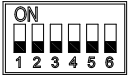
The upper limit for parallel battery connections is 4 units.

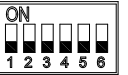
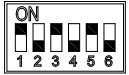
Note: The fifth bit of the address dial code for the first and last batteries should be set.

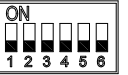
| | 1 | 2 | 3 | 4 |
|----------|---|---|--|---|
| Address |  |  |  |  |
| Function |  |  |  |  |
| Inverter |  |  |  |  |

5.4.5. USB Port

USB Port for firmware upgrade and storage log data, leave it open if not used.

5.4.6. Dry Contact

Terminal type: 6-Pin terminal block

This is for General-purpose output which reserved for future communication and used for an uncommitted digital signal pin on an integrated circuit or electronic circuit (e.g. MCUs/MPUs) board which may be used as an output, and is controllable by software.

Defined as below:

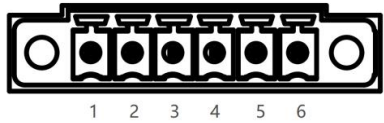
| 6pin Terminal | Pin | Usage |
|---|-----|---------------------------------|
|  | 1 | DRY1_NO |
| | 2 | DRY1 |
| | 3 | DRY1_NC |
| | 4 | DRY2_NO |
| | 5 | DRY2 / Emergency stop node 1 |
| | 6 | DRY2_NC / Emergency stop node 1 |

5.4.7. Inverter Communication Port (connector)

Terminal type: 6-Pin terminal block

Usage: Reserved for direct connection with inverter, same function as the RJ45 port (chapter " **Inverter Communication Port (RJ45)**"), either one of these two will be used.

Defined as below:

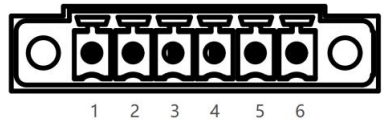
| 6pin Terminal | Pin | Usage |
|---|-----|------------|
|  | 1 | RS485_2B |
| | 2 | RS485_2A |
| | 3 | RS485_2GND |
| | 4 | CAN2L |
| | 5 | CAN2H |
| | 6 | CAN2GND |

5.4.8. Inverter Communication Port (RJ45)

Terminal type: RJ45

Usage: Communicates with inverter, PCS or other equipment.

Installer needs to check the cable pin out before connecting inverter to the battery in order to gain the communication.

For the general information or technical matters in regarding to inverter, please refers to user manual.

Illustration for battery connection port as shown below:

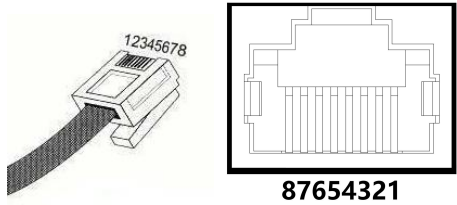
| Port definitions | RJ45 Pin | Function |
|---|----------|----------|
|  | 1 | RS485_2B |
| | 2 | RS485_2A |
| | 3 | SGND |
| | 4 | SGND |
| | 5 | SGND |
| | 6 | SGND |
| | 7 | CAN2H |
| | 8 | CAN2L |

5.4.9. Debug Port

Terminal type: RJ45

Usage: Debug port of the system which used by technician only.

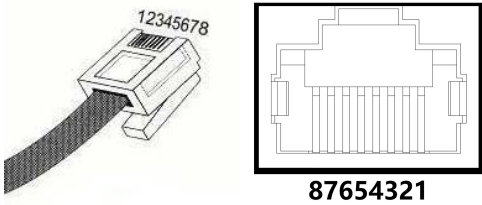
| Port definitions | RJ45 Pin | Function |
|---|----------|------------|
|  | 1 | RS485_2B |
| | 2 | RS485_2A |
| | 3 | RS485_2GND |
| | 4 | CAN1GND |
| | 5 | CAN2GND |
| | 6 | RS485_2GND |
| | 7 | CAN1H |
| | 8 | CAN1L |

5.4.10. Link A and Link B

Link A and Link B is reserved, leave them open.

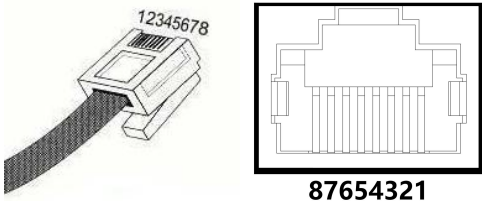
| Port definitions | RJ45 Pin | Function |
|---|----------|----------|
|  | 1 | CAN2L |
| | 2 | CAN2H |
| | 3 | CAN2GND |
| | 4 | CAN2GND |
| | 5 | CAN2GND |
| | 6 | CAN2GND |
| | 7 | CAN2H |
| | 8 | CAN2L |

5.4.11. Power Positive & Negative

| OT terminal | Screw | Torsion | Wire diameter |
|-------------|-------|-------------|---------------|
| RNB14-6 | M6 | 6.0-6.5 N.m | 6 AWG |

5.4.12. Power Switch

Power switch: Power on/off the main circuit of the battery.

5.4.13. Active Switch

Twist the switch right to active the main controller circuit, after power on, please twist it to upside, otherwise the output will be disable.

5.4.14. On/Off





Press this button once to power on the system, and press it again to power off.

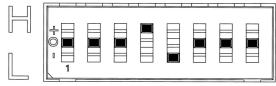
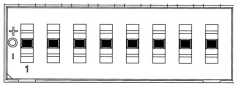
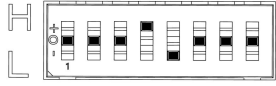
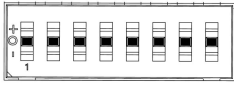
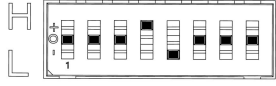
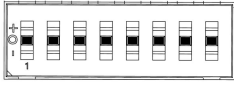
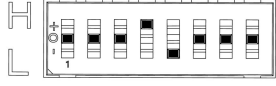

5.4.15. WiFi Antenna

Connect the WIFI antenna to the port in order to get the APP and WEB Function.

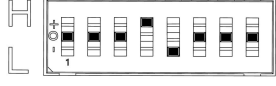
5.4.16. Dial Code Switch

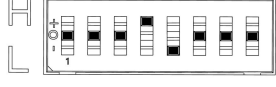
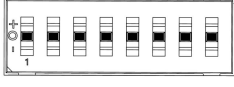
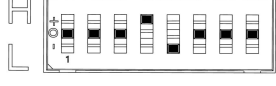
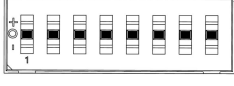
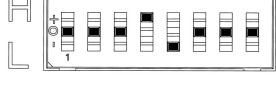
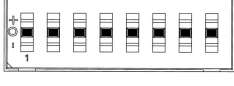
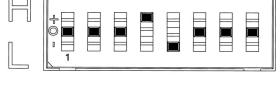
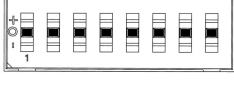
If you are using the pin order select box, please refer to the table below to set the dial switch, according to the inverter brand. If the inverter brand is not shown in the table, please refer to the inverter manual or consult Renon's engineer.

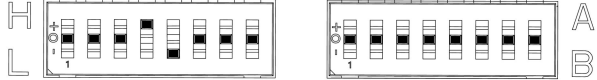
| Dial switch position | | Inverter brand | Comm Mode |
|--|--|----------------|-----------|
|  CAN |  RS485 | Renon | CAN |
|  CAN |  RS485 | Sol-Ark | CAN |
|  CAN |  RS485 | Sermatec | CAN |
|  CAN |  RS485 | Invt | CAN |
|  CAN |  RS485 | ThinkPower | CAN |
|  CAN |  RS485 | Deye | CAN |
|  CAN |  RS485 | ATESS | CAN |
|  CAN |  RS485 | Solis | CAN |
|  CAN |  RS485 | Growatt | CAN |

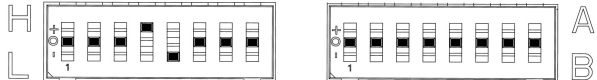
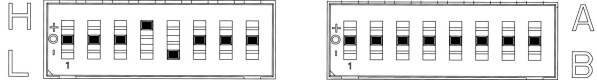
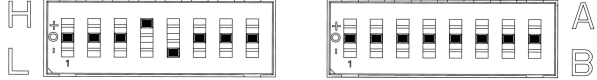
| | | |
|---|-----------------|------------|
|  <p>CAN RS485</p> | <p>MEGAREVO</p> | <p>CAN</p> |
|  <p>CAN RS485</p> | <p>Sofar</p> | <p>CAN</p> |
|  <p>CAN RS485</p> | <p>Renac</p> | <p>CAN</p> |
|  <p>CAN RS485</p> | <p>AFORE</p> | <p>CAN</p> |
|  <p>CAN RS485</p> | <p>SINENG</p> | <p>CAN</p> |
|  <p>CAN RS485</p> | <p>Solinteg</p> | <p>CAN</p> |

5.5. Monitoring Screen

5.5.1. LCD Screen Introduction

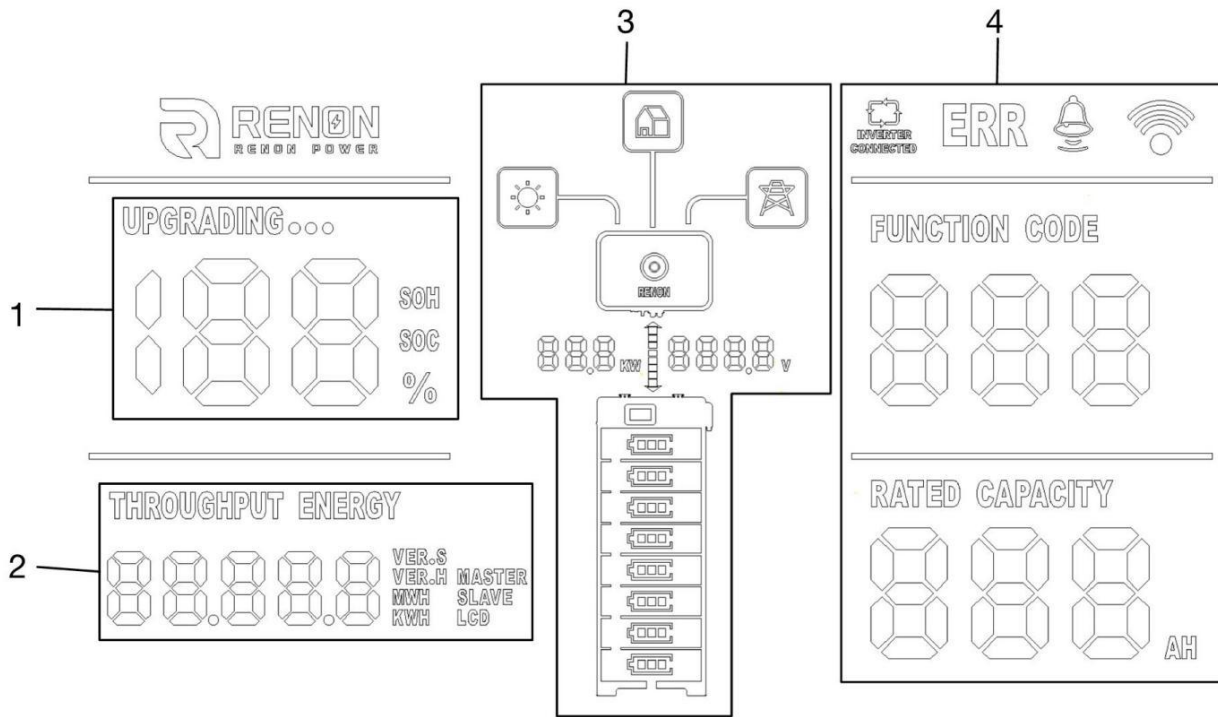

Figure 5.4.1 LCD Screen Introduction

| No. | Instructions |
|-----|--|
| 1 | SOC, SOH and Upgrading State |
| 2 | Version and Accumulated Discharge Energy |
| 3 | ESS status, Power, and Voltage |
| 4 | Battery Operation State |

5.5.2. SOC, SOH and Upgrading State

1) The SOC percentage displays when the SOC symbol displays a light underneath, and the current SOH when there is a blinking light underneath SOH. The SOC lights up in 60 second intervals, and the SOH lights up in 3 second intervals.

2) The “UPGRADING...” icon will show up when the battery is performing an upgrade. The percentage indicates the progress of the upgrade.

5.5.3. Version and Accumulated Discharge Energy

The number shows the version of software and hardware for LCD, master, slave, and accumulated discharged energy in kWh or MWh, respectively. Each item will be displayed in 3 second intervals.

5.5.4. ESS status, Power, and Voltage

1) This number displays current power and volage of the complete battery stack. Direction of the arrow between those two numbers indicates if it's charging or discharging.

2) The battery module icons will indicate the number of battery modules. Online modules will have lights on constantly while offline modules will blink periodically.

5.5.5. Battery Operation Status

1) Indication Code

If there is any error or warning sign, the Indication Code will show up. When the Indication Code displays "ERR", it means an error has occurred. The Indication Code displays "🔔" as a warning reminder. When there is no warning or error, the function code will show as 0.

2) Inverter Connection

"INVERTER CONNECTION" indicates the status of the connection between inverter and battery. It will display when proper connection is detected. Otherwise, it will be off. Some inverters do not feedback signal to battery, this symbol may always off.

3) WiFi Connection Symbol

The WiFi icon will display as long as the WiFi connection id sufficient. It will blink periodically when the WiFi configured for the battery cannot connect to the server. Off means the battery is waiting for WiFi configuration.

| No. | Status | Instructions |
|-----|---------------------------|--------------|
| 1 | Cloud platform connection | Light on |
| 2 | WiFi connection | Flashing |
| 3 | Not connection | Light off |

4) Rated Capacity

Rated Capacity indicates the nominal capacity of current cluster.

5.6. Screen Display Code

Warning Code (Sign like “”)

| Code | Warning Type |
|------|--|
| 1 | Battery cell undervoltage protection |
| 2 | Overcurrent charge protection |
| 3 | Overcurrent discharge protection |
| 4 | High charge temp protection |
| 5 | High discharge temp protection |
| 6 | Low charge temp protection |
| 7 | Low discharge temp protection |
| 8 | High ambient temp protection |
| 9 | Excessive voltage difference protection |
| 10 | Excessive temp of main control relay |
| 11 | Overtemp protection of master DC busbar |
| 12 | Low insulation resistance protection |
| 13 | Low total voltage protection |
| 14 | Low ambient temp protection |
| 15 | High MOS temp protection |
| 16 | Battery cell overvoltage protection |
| 17 | High total voltage protection |
| 18 | Low SOC protection |
| 19 | Overcurrent discharge 2 protection |
| 21 | Excessive temp difference protection |
| 22 | Positive connector high temp protection |
| 23 | Negative connector high temp protection |
| 24 | Relay high temp protection |
| 25 | Positive high temp protection for docking terminal |
| 26 | Negative high temp protection for docking terminal |

| | |
|-----|--|
| 27 | Positive high temp protection for discharge port |
| 28 | Negative high temp protection for discharge port |
| 30 | Charger overvoltage protection |
| 400 | PCS disconnect (All-in-one only) |

Error Code (Display as: "ERR")

| Code | Warning Type |
|------|---|
| 100 | The main control discharge relay is faulty |
| 101 | The main control charge relay is faulty |
| 102 | Battery cell fault |
| 103 | NTC fault |
| 104 | Current sensor fault |
| 105 | Pack disconnection |
| 106 | Short circuit fault |
| 107 | Internal total voltage detection fault |
| 108 | Heating fault |
| 109 | Battery module conflict |
| 110 | Cluster address conflict |
| 111 | Charge MOS fault |
| 112 | Discharge MOS fault |
| 113 | Addressing failure |
| 114 | Precharge fault |
| 115 | Cluster disconnection |
| 116 | Battery reverse connection fault |
| 117 | External total voltage detection fault |
| 118 | Address non-1 fault |
| 119 | Address break-sign failure |
| 121 | The faulty of power on switch is not turned off |



| | |
|-----|--|
| 123 | Microelectronic fault |
| 124 | Smoke sensor fault |
| 125 | The number of slave voltage strings does not match |
| 126 | Temp NTC short circuit of master relay |
| 127 | Temp NTC open circuit of master relay |
| 128 | Temp NTC short circuit of master DC busbar |
| 129 | Temp NTC open circuit of master DC busbar |
| 130 | Master drop-off fault |
| 132 | EMS SN is empty |
| 133 | Master SN is empty |
| 134 | Pack SN is empty |
| 136 | High voltage relay fault |
| 137 | DC breaker disconnect |
| 138 | Overcurrent charge 2 protection |
| 200 | Battery cell undervoltage safety lock |
| 201 | Battery cell high voltage safety lock |
| 202 | Charge high temp safety lock |
| 203 | Charge low temp safety lock |
| 204 | Discharge high temp safety lock |
| 205 | Discharge low temp safety lock |
| 206 | Charge overcurrent safety lock |
| 207 | Discharge overcurrent safety lock |

6. Troubleshooting & Maintenance

6.1. Regular Maintenance

- 1) Check the battery modules every 3 months to verify whether there are damages.
- 2) Check the battery modules every 3 months to verify whether the operating parameter is normal or there is no abnormal heating.
- 3) Fully charge and discharge the battery system every 3 months.
- 4) Clean the battery modules with a dry rag once a month.

6.2. Troubleshooting

| Phenomenon | Investigation & troubleshooting |
|--|---|
| <p>The number of battery module symbol is incorrect.</p>  | <ol style="list-style-type: none"> 1. Make sure the whole battery system is stacked neatly. 2. Try to restart the battery system. |
| <p>The symbol of battery modules on the screen is blinking (frequency of 1s)</p>  | <ol style="list-style-type: none"> 1. Make sure the whole battery system is stacked neatly. 2. Make sure the function dial switch code setting is correct, please refer to chapter “function dial switch”. 3. Try to restart the battery system. |
| <p>Unable to turn on the battery</p> | <ol style="list-style-type: none"> 1. Try to charge the battery with the activation charging function on the inverter when power is on. |
| <p>Unable to find the battery on the app or the Cloud</p> | <ol style="list-style-type: none"> 1. Make sure the antenna is tightened properly. 2. Make sure the WiFi configuration is correct. 3. Make sure the SSID & PASSWORD of your private WiFi is correct, please enter information case-sensitively without space. 4. Make sure the frequency of the WiFi connected to the product is not 5GHz (2.4GHz and 2.4GHz / 5GHz is acceptable). 5. Make sure the signal is strong enough. 6. Make sure is working. 7. Make sure installer has added your products to your account. 8. Try to restart the WiFi router. |

| | |
|--|---|
| No output after power on. | <ol style="list-style-type: none"> 1. Make sure the address dial code setting is correct, refer to the chapter of address dial code. 2. Make sure SOC is not 0%, otherwise charge battery. 3. Make sure the activate switch is rotate to "OFF" (upside). |
| Unable to communicate with inverter | <ol style="list-style-type: none"> 1. Make sure the connection of communication cable and power cable is correct, refer to the chapter of connection of cable and power. 2. Make sure the address dial code of the master controller connected to inverter is 1. 3. Make sure the inverter dial code of the master controller connected to inverter is correct, refer to the chapter of inverter dial code. 4. If you are using a pin order select box, please verify that the dialing switch is configured correctly. |
| Unable to be charged by inverter | <ol style="list-style-type: none"> 1. Make sure power cable connection is correct. 2. Check whether inverter has faults. 3. Check whether grid or PV is available. 4. Make sure Time of Use of the inverter setting is correct. 5. Make sure charging voltage and charging current setting of the inverter match the parameters of the battery. 6. Check the battery low or high temperature protection alarm. 7. Check the over current protection alarm. 8. Make sure the SOC value is below 96% (default value). |
| Unable to discharge while SOC is not zero. | <ol style="list-style-type: none"> 1. Make sure the connection of cables is correct and circuit breaker is ON. 2. Check whether inverter has faults. 3. Make sure the inverter setting is not in back up mode. 4. Check whether SOC is lower than the shutdown value of the inverter. 5. Check the battery low or high temperature protection alarm. 6. Check the over current protection alarm. |
| SOC value change instantly. | <ol style="list-style-type: none"> 1. It is normal that the SOC value will be calibrated when the battery has been fully charged, or deeply discharged. |
| Error or Alarm shown on the screen | <ol style="list-style-type: none"> 1. Check the battery. Refer to the definition of the error or warning codes. If you cannot determine the cause of the error. |

6.3. Status Codes

The following status codes are displayed on the cloud platform.

6.3.1. Warning Codes

| Code | Warning type | Investigation & troubleshooting |
|------|---------------------------------|---|
| W1 | Battery cell undervoltage alarm | 1. Low voltage level and needs to be charged. |
| W2 | Charge overcurrent alarm | 1. Restore to factory setting; 2. Make sure the inverter's setting of max current does not exceed the max charge current of the battery. |
| W3 | Discharge overcurrent 1 alarm | 1. Make sure the power of load does not exceed the power of battery. |
| W4 | High charge temp alarm | 1. Make sure the battery temperature shown on the inverter or the app is below 131°F (55°C), otherwise turn off the battery until the temperature is below 131°F (55°C), and then try to charge battery. |
| W5 | High discharge temp alarm | 1. Make sure the battery temperature shown on the inverter or the app is below 131°F (55°C), otherwise turn off the battery until the temperature is below 131°F (55°C), and then try to discharge battery. |
| W6 | Low charge temp alarm | 1. Make sure the battery temperature shown on the inverter or the app is above 32°F (0°C), otherwise turn off the battery until the temperature is above 32°F (0°C), and then try to charge battery. |
| W7 | Low discharge temp alarm | 1. Make sure the battery temperature shown on the inverter or the app is above -4°F (-20°C), otherwise turn off the battery until the temperature is above -4°F (-20°C), and then try to charge battery. |
| W8 | High ambient temp alarm | 1. Make sure the ambient temperature of the battery is below 122°F (50°C). |
| W9 | High voltage difference alarm | 1. Restart the battery, and if error code W9 still remains or reappears, contact your installer. |
| W11 | High main DC busbar temp alarm | 1. Restart the battery, and if error code W11 still remains or reappears, contact your installer. |
| W12 | Low insulation resistance alarm | 1. Restart the battery, and if error code W12 still remains or reappears, contact your installer. |
| W13 | Low total voltage alarm | 1. Low voltage level and needs to be charged |
| W14 | Low ambient temp alarm | 1. Make sure the ambient temperature of the battery is above -13°F (-25°C). |

| | | |
|------|---|--|
| W15 | High MOS temp alarm | 1. Reduce the ambient temperature and restart the battery. |
| W16 | Battery cell overvoltage alarm | 1. High voltage level and needs to be discharged. |
| W17 | High total voltage alarm | 1. High voltage level and needs to be discharged. |
| W18 | Low SOC alarm | 1. Low SOC and needs to be charged. |
| W21 | High temp difference alarm | 1. Restart the battery, and if error code W21 still remains or reappears, contact your installer. |
| W22 | Positive connector high temp alarm | 1. Restart the battery, and if error code W22 still remains or reappears, contact your installer. |
| W23 | Negative connector high temp alarm | 1. Restart the battery, and if error code W23 still remains or reappears, contact your installer. |
| W24 | Relay high temp alarm | 1. Restart the battery, and if error code W24 still remains or reappears, contact your installer. |
| W25 | Positive high temp alarm for docking terminal | 1. Restart the battery, and if error code W25 still remains or reappears, contact your installer. |
| W26 | Negative high temp alarm for docking terminal | 1. Restart the battery, and if error code W26 still remains or reappears, contact your installer. |
| W27 | Positive high temp alarm for discharge port | 1. Restart the battery, and if error code W27 still remains or reappears, contact your installer. |
| W28 | Negative high temp alarm for discharge port | 1. Restart the battery, and if error code W28 still remains or reappears, contact your installer. |
| W400 | PCS disconnection | 1. Restart the battery, and if error code W400 still remains or reappears, contact your installer. |

6.3.2. Error Codes

| Code | Error Type | Investigation & troubleshooting |
|------|--|--|
| F100 | The main control discharge relay is faulty | 1. Restart the battery, and if error code F100 still remains or reappears, contact your installer. |
| F101 | The main control charge relay is faulty | 1. Restart the battery, and if error code F101 still remains or reappears, contact your installer. |
| F102 | Battery cell fault | 1. Restart the battery, and if error code F102 still remains or reappears, contact your installer. |
| F103 | NTC fault | 1. Restart the battery, and if error code F103 still remains or reappears, contact your installer. |
| F104 | Current sensor fault | 1. Restart the battery, and if error code F104 still remains or reappears, contact your installer. |
| F105 | Pack disconnection | 1. Restart the battery, and if error code F105 still remains or reappears, contact your installer. |
| F106 | Short circuit fault | 1. Make sure the external connection for both battery and inverters are proper; 2. Disconnect all external connections and restart the battery, and if error code F106 still, contact your installer. |
| F107 | Internal total voltage detection fault | 1. Restart the battery, and if error code F107 still remains or reappears, contact your installer. |
| F108 | Heating fault | 1. Restart the battery, and if error code F108 still remains or reappears, contact your installer. |
| F109 | Battery module conflict | 1. Restart the battery, and if error code F109 still remains or reappears, contact your installer. |
| F110 | Cluster address conflict | 1. Restart the battery, and if error code F110 still remains or reappears, contact your installer. |
| F111 | Charge MOS fault | 1. Restart the battery, and if error code F111 still remains or reappears, contact your installer. |
| F112 | Discharge MOS fault | 1. Restart the battery, and if error code F112 still remains or reappears, contact your installer. |
| F113 | Addressing failure | 1. Restart the battery, and if error code F113 still remains or reappears, contact your installer. |
| F114 | Precharge fault | 2. Restart the battery, and if error code F114 still remains or reappears, contact your installer. |

| | | |
|------|--|--|
| F115 | Cluster disconnection | 1. Restart the battery, and if error code F115 still remains or reappears, contact your installer. |
| F116 | Battery reverse connection fault | 1. Restart the battery, and if error code F116 still remains or reappears, contact your installer. |
| F117 | External total voltage detection fault | 1. Restart the battery, and if error code F117 still remains or reappears, contact your installer. |
| F118 | Address non-1 fault | 1. Restart the battery, and if error code F118 still remains or reappears, contact your installer. |
| F119 | Address break-sign failure | 1. Restart the battery, and if error code F119 still remains or reappears, contact your installer. |
| F120 | Pack disconnect fault | 1. Restart the battery, and if error code F120 still remains or reappears, contact your installer. |
| F121 | The faulty of power on switch is not turned off | 1. Restart the battery, and if error code F121 still remains or reappears, contact your installer. |
| F123 | Microelectronic fault | 1. Restart the battery, and if error code F123 still remains or reappears, contact your installer. |
| F124 | Smoke sensor fault | 1. Restart the battery, and if error code F124 still remains or reappears, contact your installer. |
| F125 | The number of slave voltage strings does not match | 1. Restart the battery, and if error code F125 still remains or reappears, contact your installer. |
| F126 | Temp NTC short circuit of master relay | 1. Restart the battery, and if error code F126 still remains or reappears, contact your installer. |
| F127 | Temp NTC open circuit of master relay | 1. Restart the battery, and if error code F127 still remains or reappears, contact your installer. |
| F128 | Temp NTC short circuit of master DC busbar | 1. Restart the battery, and if error code F128 still remains or reappears, contact your installer. |
| F129 | Temp NTC open circuit of master DC busbar | 1. Restart the battery, and if error code F129 still remains or reappears, contact your installer. |
| F130 | Master drop-off fault | 1. Restart the battery, and if error code F130 still remains or reappears, contact your installer. |
| F132 | EMS SN is empty | 1. Restart the battery, and if error code F132 still remains or reappears, contact your installer. |

| | | |
|------|---------------------------------------|--|
| F133 | Master SN is empty | 1. Restart the battery, and if error code F133 still remains or reappears, contact your installer. |
| F134 | Pack SN is empty | 1. Restart the battery, and if error code F134 still remains or reappears, contact your installer. |
| F136 | High voltage relay fault | 1. Restart the battery, and if error code F136 still remains or reappears, contact your installer. |
| F137 | DC breaker disconnect | 1. Restart the battery, and if error code F137 still remains or reappears, contact your installer. |
| F138 | Overcurrent charge 2 protection | 1. Restart the battery, and if error code F138 still remains or reappears, contact your installer. |
| F200 | Battery cell undervoltage safety lock | 1. Restart the battery, and if error code F200 still remains or reappears, contact your installer. |
| F201 | Battery cell high voltage safety lock | 1. Restart the battery, and if error code F201 still remains or reappears, contact your installer. |
| F202 | Charge high temp safety lock | 1. Restart the battery, and if error code F202 still remains or reappears, contact your installer. |
| F203 | Charge low temp safety lock | 1. Restart the battery, and if error code F203 still remains or reappears, contact your installer. |
| F204 | Discharge high temp safety lock | 1. Restart the battery, and if error code F204 still remains or reappears, contact your installer. |
| F205 | Discharge low temp safety lock | 1. Restart the battery, and if error code F205 still remains or reappears, contact your installer. |
| F206 | Charge overcurrent safety lock | 1. Restart the battery, and if error code F206 still remains or reappears, contact your installer. |
| F207 | Discharge overcurrent safety lock | 1. Restart the battery, and if error code F207 still remains or reappears, contact your installer. |

6.3.3. Protection Codes

| Code | Error Type | Investigation & troubleshooting |
|------|---|--|
| P1 | Battery cell undervoltage protection | 1. Low voltage level and needs to be charged. |
| P2 | Overcurrent charge protection | 1. Restore to factory setting; 2. Make sure the inverter's setting of max current does not exceed the max charge current of the battery. |
| P3 | Overcurrent discharge protection | 1. Make sure the power of load does not exceed the power of battery. |
| P4 | High charge temp protection | 1. Make sure the battery temperature shown on the inverter or the app is below 131°F (55°C), otherwise turn off the battery until the temperature is below 131°F (55°C), and then try to charge battery. |
| P5 | High discharge temp protection | 1. Make sure the battery temperature shown on the inverter or the app is below 131°F (55°C), otherwise turn off the battery till the temperature is below 131°F (55°C), and then try to discharge battery. |
| P6 | Low charge temp protection | 1. Make sure the battery temperature shown on the inverter or the app is above 32°F (0°C), otherwise turn off the battery till the temperature is above 32°F (0°C), and then try to charge battery. |
| P7 | Low discharge temp protection | 1. Make sure the battery temperature shown on the inverter or the app is above -4°F (-20°C), otherwise turn off the battery till the temperature is above -4°F (-20°C), and then try to charge battery. |
| P8 | High ambient temp protection | 1. Make sure the ambient temperature of the battery is below 122°F (50°C). |
| P9 | Excessive voltage difference protection | 1. Restart the battery, and if error code P9 still remains or reappears, contact your installer. |
| P10 | Excessive temp of main control relay | 1. Reduce the ambient temperature, and restart the battery. |
| P11 | Overtemp protection of master DC busbar | 1. Reduce the ambient temperature, and restart the battery. |
| P12 | Low insulation resistance protection | 1. Restart the battery, and if error code P12 still remains or reappears, contact your installer. |
| P13 | Low total voltage protection | 1. Low voltage level, and needs to be charged. |
| P14 | Low ambient temp protection | 1. Make sure the ambient temperature of the battery is above -13°F (-25°C). |

| | | |
|-----|--|---|
| P15 | High MOS temp protection | 1. Reduce the ambient temperature, and restart the battery. |
| P16 | Battery cell overvoltage protection | 1. High voltage level, and needs to be discharged. |
| P17 | High total voltage protection | 1. High voltage level, and needs to be discharged. |
| P18 | Low SOC protection | 1. Low voltage level, and needs to be charged. |
| P19 | Overcurrent discharge 2 protection | 1. Make sure the power of load does not exceed the power of battery. |
| P21 | Excessive temp difference protection | 1. Restart the battery, and if error code P21 still remains or reappears, contact your installer. |
| P22 | Positive connector high temp protection | 1. Reduce the ambient temperature, and restart the battery. |
| P23 | Negative connector high temp protection | 1. Reduce the ambient temperature, and restart the battery. |
| P24 | Relay high temp protection | 1. Reduce the ambient temperature, and restart the battery. |
| P25 | Positive high temp protection for docking terminal | 1. Reduce the ambient temperature, and restart the battery. |
| P26 | Negative high temp protection for docking terminal | 1. Reduce the ambient temperature, and restart the battery. |
| P27 | Positive high temp protection for discharge port | 1. Reduce the ambient temperature, and restart the battery. |
| P28 | Negative high temp protection for discharge port | 1. Reduce the ambient temperature, and restart the battery. |
| P30 | Charger overvoltage protection | 1. Restart the battery, and if error code P30 still remains or reappears, contact your installer. |

P/N: 118.601.00.0144



Renon Power Technology Inc.

5900 Balcones Drive Suite 100, Austin, TX 78731 USA

Renon Power Solutions Sp.z o.o.

ul. ELBLĄSKA 1, 93-459, ŁÓDŹ, POLAND

Renon Power Technology B.V.

Rietbaan 10, 2908 LP Capelle aan den IJssel

Renon Power 株式会社

東京都中央区日本橋箱崎町 20-5 VORT 箱崎 5F



WhatsApp



LinkedIn



Website