

# User Manual

## Xtreme LV 1.0

**A13 VERSION**

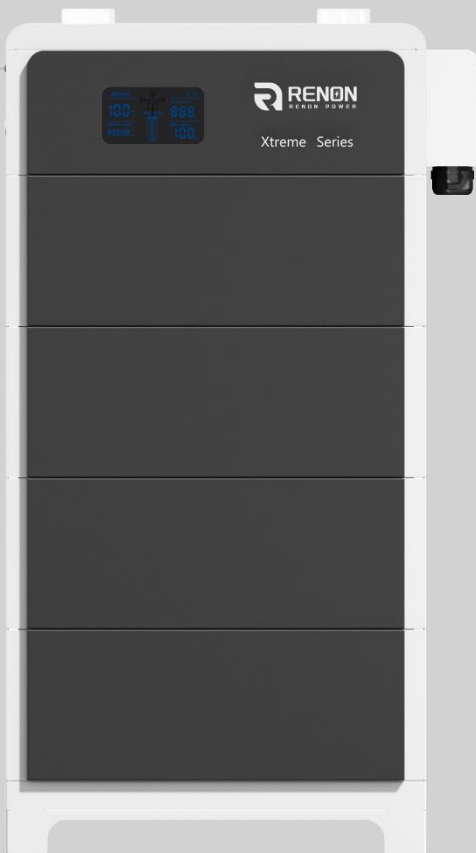

E-mail: [support@renonpower.com](mailto:support@renonpower.com)

Website: [www.renonpower.com](http://www.renonpower.com)

**Renon Power Technology Inc.**

© Renon Power Technology Inc.  
All Rights Reserved Specifications are subject to change without notice.



# Renon Power

## We Care About Sustainability

With our own R&D team and automatic production factory, we are dedicated to delivering innovative, reliable, and affordable energy storage solutions to global customers.

At Renon, we believe that sustainable energy is the future. We are passionate about reducing carbon emissions and preserving our planet for future generations. That's why we invest heavily in research and development, leveraging the latest technologies to design and manufacture energy storage systems that are efficient, scalable, and adaptable.

Our products are designed to meet the needs of a wide range of applications, from residential and commercial buildings to industrial facilities and utility-scale projects. Whether you're looking to reduce your energy bills, increase your energy independence, or support your sustainability goals, Renon has the right solution for you.

Our commitment to quality and customer satisfaction is unwavering. We work closely with our clients to understand their unique needs and provide customized solutions that meet or exceed their expectations. We also provide comprehensive technical support, maintenance, and warranty services to ensure that our customers get the most out of their investment.

**JOIN US ON OUR MISSION TO MAKE RENEWABLE ENERGY WITHIN REACH.**

---

**PROVIDE INNOVATIVE,  
RELIABLE, AND  
AFFORDABLE ENERGY  
STORAGE SOLUTIONS  
TO CUSTOMERS**

---



# Table of Contents

|   |    |
|---|----|
| 1 Safety Instructions .....                               | 6  |
| 1.1 General Safety Precautions .....                      | 6  |
| 1.2 Transportation and Storage Precautions .....          | 6  |
| 1.3 Installation Precautions .....                        | 7  |
| 1.4 Usage Precautions .....                               | 8  |
| 1.5 Response to Emergency Situations .....                | 8  |
| 1.6 Qualified Personnel .....                             | 9  |
| 2 Preparation before Installation .....                   | 10 |
| 2.1 Safe Handling Guide .....                             | 10 |
| 2.1.1 Familiar yourself with the Battery .....            | 10 |
| 2.1.2 Precautions .....                                   | 10 |
| 2.1.3 Tools .....   | 10 |
| 2.1.4 Safety Gear .....                                   | 11 |
| 2.2 System Premeasurement .....                           | 11 |
| 2.3 Installation Location .....                           | 11 |
| 2.4 Package Items .....                                   | 12 |
| 3 Installation .....                                      | 14 |
| 3.1 Device Installation .....                             | 14 |
| 3.2 Connection .....                                      | 17 |
| 3.3 Application Scenarios .....                           | 20 |
| 3.3.1 Single Stack .....                                  | 20 |
| 3.3.2 Parallel .....                                      | 21 |
| 3.3.3 Precautions for Multiple Parallel Connections ..... | 21 |
| 4 Cloud Platform Configuration .....                      | 24 |
| 5 Battery Specifications .....                            | 33 |
| 5.1 Product Features .....                                | 33 |
| 5.2 Specifications .....                                  | 34 |
| 5.2.1 Specifications 1 (16 series cells) .....            | 34 |
| 5.2.2 Specifications 1 (15 series cells) .....            | 35 |

|  |    |
|--|----|
| 5.3 Function Introduction .....                      | 36 |
| 5.3.1 Protection .....                               | 36 |
| 5.3.2 Heating .....                                  | 36 |
| 5.3.3 Forced Discharge .....                         | 36 |
| 5.3.4 Full Charge .....                              | 36 |
| 5.3.5 Charging Self-Adaptation Control .....         | 36 |
| 5.3.6 Safety Lock .....                              | 36 |
| 5.4 Interface Information .....                      | 37 |
| 5.4.1 Power Button .....                             | 37 |
| 5.4.2 WiFi Antenna Port7 .....                       | 38 |
| 5.4.3 Inverter Dial Switch .....                     | 38 |
| 5.4.4 Address Dial Switch .....                      | 39 |
| 5.4.5 Function Dial Switch .....                     | 40 |
| 5.4.6 Inverter Communication Port .....              | 41 |
| 5.4.7 Debug Port .....                               | 41 |
| 5.4.8 INVERTER 1 Port (RJ45) .....                   | 42 |
| 5.4.9 INVERTER 2 Port (RJ45) .....                   | 42 |
| 5.4.10 Parallel Communication Port A & B .....       | 43 |
| 5.4.11 Power Negative &Positive .....                | 43 |
| 5.4.12 Dial Code Switch .....                        | 43 |
| 5.5 LCD Screen .....                                 | 46 |
| 5.5.1 SOC, SOH and Upgrading State .....             | 47 |
| 5.5.2 Version and Accumulated Discharge Energy ..... | 47 |
| 5.5.3 ESS Status, Power, and Voltage .....           | 47 |
| 5.5.4 Battery Operation Status .....                 | 47 |
| 5.5.5 Screen Display Code .....                      | 48 |
| 6 Troubleshooting & Maintenance .....                | 52 |
| 6.1 Regular Maintenance .....                        | 52 |
| 6.2 Troubleshooting .....                            | 52 |

|                              |    |
|------------------------------|----|
| 6.3 Status Code .....        | 54 |
| 6.3.1 Warning Codes .....    | 54 |
| 6.3.2 Error Codes .....      | 56 |
| 6.3.3 Protection Codes ..... | 59 |

# 1 Safety Instructions

*For safety reasons, installer and user are responsible for familiarizing themselves with the contents of this document and all warnings before installation and usage.*

## 1.1 General Safety Precautions

- Please carefully read this manual before any work is carried out on the product, and keep it located near the product for future reference.
- All installation and operation must comply with local electrical standards.
- Please ensure the electrical parameters of the product are compatible to related equipment.
- Do not open or dismantle the battery module. Electrolyte is very corrosive. In normal working conditions contact with the electrolyte is impossible. If the battery casing is damaged, do not touch the exposed electrolyte or powder because it is corrosive.
- The electronics inside the product are vulnerable to electrostatic discharge.
- Do not place items or tools on the product.
- Do not damage the product by dropping, deforming, impacting, or cutting.
- Keep the product away from liquid. Do not touch the product if liquid spills on it. There is a risk of electric shock.
- Do not expose the product to flammable or harsh chemicals or vapors.
- Do not paint any part of the product, include any internal or external components.
- Do not change any part of the product, especially the battery and cell.
- Besides connection under this manual, any other foreign object is prohibited from being inserted into any part of the product.
- The warranty claims are excluded for direct or indirect damage due to items above.
- Batteries must not be mixed with domestic or industrial waste.
- Batteries marked with the recycling symbol must be processed via a recognized recycling agency. By agreement, they may be returned to the manufacturer.

## 1.2 Transportation and Storage Precautions

- The batteries must be transported according to UN3480, they must be packed according to packaging requirements of Special Regulation 230 of IMDG CODE (40-20 Edition) for maritime transport, and P965 IA for air transport (SOC less than 30%). The original packaging complies with these instructions.
- If the product needs to be moved or repaired, the power must be cut off and completely shut down.

- The product must be transported in its original or equivalent package; the battery module must be placed at upright position.
- The modules are heavy. Ensure adequate and secure mounting and always use suitable handling equipment for transportation.
- If the product is in its package, use soft slings to avoid damage.
- Do not stand below the product when it is hoisted.
- During transportation, severe impact, extrusion, direct sunlight, and rain should be avoided.
- Store in a cool and dry place.
- Store the product in clean environment, free of dust, dirt, and debris.
- Store the product out of reach of children and animals.
- Don't store the battery under 50% SOC for over one month. This may result in permanent damage to the battery and void the warranty.
- During long term storage, it is required to charge the battery module every 3 months, and the SOC should be no less than 90%.

### **1.3 Installation Precautions**

- Do not install the product in an airtight enclosure or in an area without ventilation.
- Do not install the product in living areas of dwelling units or in sleeping units other than within utility closets and storage or utility spaces.
- If the product is installed in a garage or carport, ensure there is adequate clearance from vehicles.
- While working on the product wear protective eyeglasses and clothing.
- Handle the battery wearing insulated gloves.
- Use insulated tools. Do not wear any metallic items such as watches, bracelets, etc.
- Turn-off related circuit breakers before and during the installation to avoid electric shock.
- Do not connect any AC conductors or photovoltaic conductors directly to the battery pack. These are only to be connected to the inverter.
- Wiring must be correct, do not mistake the positive and negative cables, and ensure no short circuit with the external device.
- Over-voltages or wrong wiring could damage the battery pack and cause combustion which can be extremely dangerous.
- Make sure the product is well grounded, and complies with local specifications. The recommended grounding resistance is less than  $1\Omega$ .
- Handle with care because Li-ion Battery is sensitive to mechanical shock.

## 1.4 Usage Precautions

- Before starting the system, the operator should strictly check the connection terminals to ensure that the terminals are firmly connected.
- If there's a circuit breaker between battery and inverter, the breaker is supposed to be on before powering on the battery.
- Do not open the product, connect, or disconnect any wires when it's working to avoid electric shock.
- Battery needs to be recharged within 12 hours after fully discharging.
- The default temperature range over which the battery can be discharged is  $-4^{\circ}\text{F}$  ( $-20^{\circ}\text{C}$ ) to  $122^{\circ}\text{F}$  ( $50^{\circ}\text{C}$ ). Frequently discharging the battery in high or low temperature may deteriorate the performance and life of the battery pack.
- The default temperature range over which the battery can be charged is  $32^{\circ}\text{F}$  ( $0^{\circ}\text{C}$ ) to  $122^{\circ}\text{F}$  ( $50^{\circ}\text{C}$ ). Frequently charging the battery in high or low temperature may deteriorate the performance and life of the battery pack.
- Do not charge or discharge a damaged battery.
- Please contact the supplier within 24 hours if there is something abnormal.

## 1.5 Response to Emergency Situations

- Damaged batteries are dangerous and must be handled with extreme care. They are not suitable for use and may cause danger to people or property. If the battery pack appears to be damaged, place it in the original container and return it to an authorized dealer.
- If the battery pack is wet or submerged in water, do not allow anyone to touch the water, and then contact authorized dealer for technical support.
- In case of fire, use carbon dioxide, FM-200 or ABC dry powder fire extinguisher; if possible, move the battery pack to a safe area before it catches fire.
- If a user happens to be exposed to the internal materials of the battery cell due to damage on the outer casing, the following actions are recommended.
- In case of inhalation: Leave the contaminated area immediately and seek medical attention.
- In case of contact with eyes: Rinse eyes with running water for 15 minutes and seek medical attention.
- In case of contact with skin: Wash the contacted area with soap thoroughly and seek medical attention.
- In case of ingestion: Induce vomiting and seek medical attention.

## 1.6 Qualified Personnel

The installation guide part described herein is intended for use by skilled staff only. Skilled staff is defined as a trained and qualified electrician or installer who has all the following skills and experience:

- Knowledge of battery specification and properties.
- Knowledge of the installation of electrical devices.
- Knowledge of torsion and screwdrivers for different types of screws.
- Knowledge of local installation standards.
- Electrical license for battery installation required by the country or state.
- Knowledge of the dangers and risks associated with installing and using electrical devices and acceptable mitigation methods.
- Knowledge of and adherence to this guide and all safety precautions and best practices.
- For safety reasons, installers are responsible for familiarizing themselves with the contents of this document and all warnings before performing installation and usage.

## 2 Preparation before Installation

### 2.1 Safe Handling Guide

#### 2.1.1 Familiar yourself with the Battery

Be careful when unpacking the system. Every module of the product is heavy. Don't lift them with a pole. The weight of the modules can be found in the chapter "**Specifications**".

Familiar yourself with battery. The battery poles are located on the top and bottom sides of the battery module. It's designed of fast mounting and simplicity, no need to recognize the positive and negative poles, but take care of them especially the bottom one.

#### 2.1.2 Precautions

Before installation, be sure to read the contents in chapter "**Safety Precautions**", which is related to the operation safety of installation personnel, please pay attention to it.

#### 2.1.3 Tools

The following tools are required to install the product:



Cordless Drill

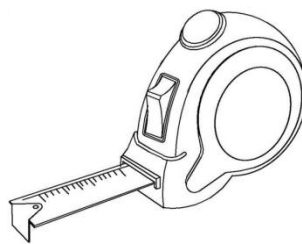

Measuring Tape



Pencil or Marker

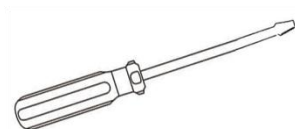

Flathead Screwdriver

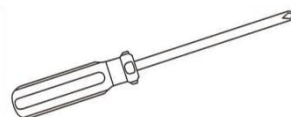

Phillips Screwdriver

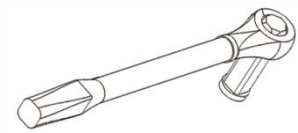

Torque Wrench

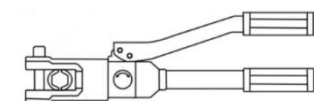

Hydraulic Clamp

Use properly insulated tools to prevent accidental electric shock or short circuits. If insulated tools are not available, cover the all exposed metal surfaces of the available tools, except their tips, with electrical tape.

### 2.1.4 Safety Gear

It is recommended to wear the following safety gear when dealing with the product:



Insulated Gloves



Safety Goggles



Safety Shoes

## 2.2 System Premeasurement

The battery requires adequate clearance for installation and airflow. The minimum clearance for system configuration is given below. The cable connected between battery pack and inverter should be in accordance with the installation guide or manual of the inverter.

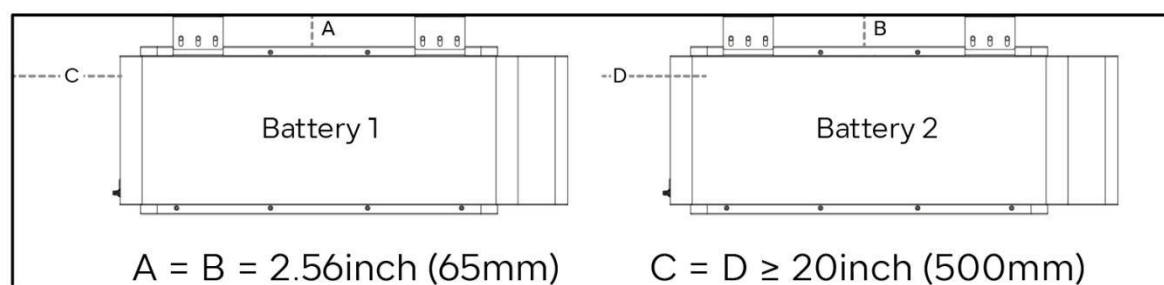

Figure 2.2.1. System clearance

## 2.3 Installation Location

Make sure that the installation location meets the following conditions:

- The floor is flat and level.
- The surface of the wall is smooth and perpendicular to the ground, which can bear the weight.
- The area is completely water proof.
- The area shall avoid direct sunlight.
- There are no flammable or explosive materials.
- The distance from heat source is more than 80 in (2m).
- The ambient temperature is within the range from 32°F (0°C) to 95°F (35°C).
- The humidity is maintained at a constant level.











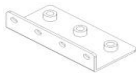

- There is minimal dust and dirt in the area.
- Avoid installation in an area confined or with high salinity.
- Do not place in an area accessible to children or pets.













## 2.4 Package Items

After receiving the product, please unpack the boxes, and check product and packing list first. If product is damaged or lacks parts, please contact the local retailer.



Here is the Xtreme Series Packing List:

(1) Main Controller:

| No. | Item                      | Specification  | Qty | Usage   | Diagram   |
|-----|---------------------------|--|-----|---|---|
| 1   | Main Controller           | R-MC300-XTL01  | 1   | Controller of the battery cluster   |    |
| 2   | Base                      | 25.0*9.4*5.7 in<br>/635*238*145 mm   | 1   | Bottom base of the battery cluster  |    |
| 3   | Mounting A                | 3.1*1.6*0.9 in<br>/80*40*22 mm   | 2   | Mounted at the rear of the controller, used to stabilize the cluster              |   |
| 4   | Mounting B                | 3.1*2.2*1.2 in<br>/80*55*30 mm   | 2   | Combines the Mounting A to wall, used to stabilize the cluster                    |  |
| 5   | Screw                     | Stainless steel M4*12<br>triple combination                                  | 8   | Fastens Mounting A to controller, fix the side panel connector to the bottom base |  |
| 6   | Screw                     | Stainless steel M6*16<br>triple combination                                  | 6   | Fastens Mounting B to A   |  |
| 7   | Allen                     | M4   | 1   | Tightens the screws on the side cover of the main controller                      |  |
| 8   | Screw                     | Plastic expansion screw<br>10x60 with M6x60 flange<br>304 self-tapping screw | 6   | Fastens Mounting B to wall  |  |
| 9   | Screw                     | M4x10, hexagon socket<br>head cap screw, 304<br>stainless steel              | 8   | Side plate fixing screws  |  |
| 10  | Screw                     | Stainless steel expansion<br>screw M8*80                                     | 4   | Fastens base to floor   |  |
| 11  | WiFi                      | 2.4/5GHz L-type  | 1   | Connects with internet  |  |
| 12  | OT Terminal<br>(Optional) | SC120-8  | 2   | Crimps power wire   |  |

|    |   |   |   |  |   |
|----|---|---|---|--|---|
| 13 | OT Terminal (Optional)                          | SC70-8  | 4 | Crimps power wire  |    |
| 14 | Communication Cable                             | RJ45 network cable T568B, 2m  | 1 | Communicates between clusters when parallel  |    |
| 15 | Inverter Communication Box and Cable (Optional) | 3.3*1.0*0.9 in /85*26*22 mm   | 1 | Sets the pin order of the communication cable of battery and inverter, cooperate with 2 standard network cable |    |
| 16 | User Manual                                     | Xtreme LV series  | 1 | User manual  |    |
| 17 | Main Control Layer                              | 163x26, Aluminum, T=4.5   | 2 | Main control sides   |    |
| 18 | Base Layer                                      | 163x15, SPCC, T=2.0   | 2 | Aluminum board sides   |    |
| 19 | Busbar (optional)                               | T2red copper, nickel plating,64x48x3, T=3mm, pitch-row27.5,2circular hole, M8 swage nut | 2 | Output busbar  |    |
| 20 | Screw(optional)                                 | M8x18, Philips, outer hexagon, carbon steel with blue zinc                              | 2 | Busbar installation  |   |
| 21 | Match Inverter System Labels                    | 108x62mm  | 1 | Sticks on the actual corresponding position of inverter  |  |
| 22 | Match Sol-Ark Inverter System Small Labels      | 38x35mm   | 1 | Sticks on the master side panel cover  |  |
| 23 | Quick Installation Manual                       | Xtreme LV series  | 1 | User manual  |  |
| 24 | Inverter Communication Cable(optional)          | RJ45 network cable  | 1 | Connects with inverter   |  |

(2) Battery Module:

| No. | Item           | Specification                    | Qty | Usage                      | Diagram   |
|-----|----------------|----------------------------------|-----|----------------------------|---|
| 1   | Battery Module | 25*9.4*5.7 in/<br>635*238*145 mm | 1   | Storage of cells           |  |
| 2   | Screw          | M4*10 screws with collar         | 4   | Side plate fixing screws   |  |
| 3   | Side plate     | 9.5*6.5*0.2 in<br>/240*164*5 mm  | 2   | To fix the battery modules |  |

### 3 Installation

#### 3.1 Device Installation

- 1) Take the device out of the box
- 2) Place the base on the ground, and then measure 65mm from the back of the base to the wall. Then use M8 screws to punch holes in the positions marked in the figure below and fix the base.

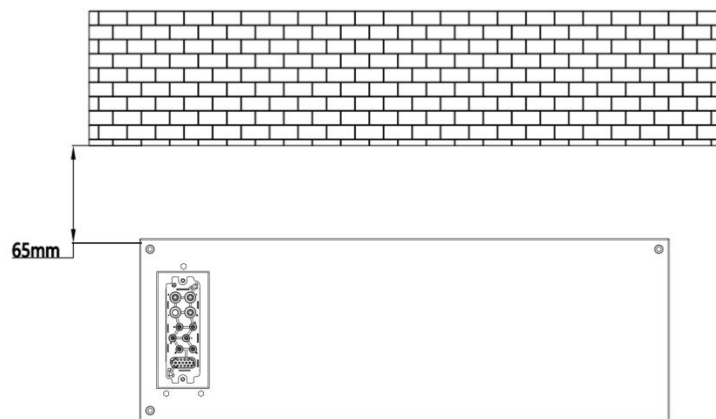

*Figure 3.1.1. Mounting distance*

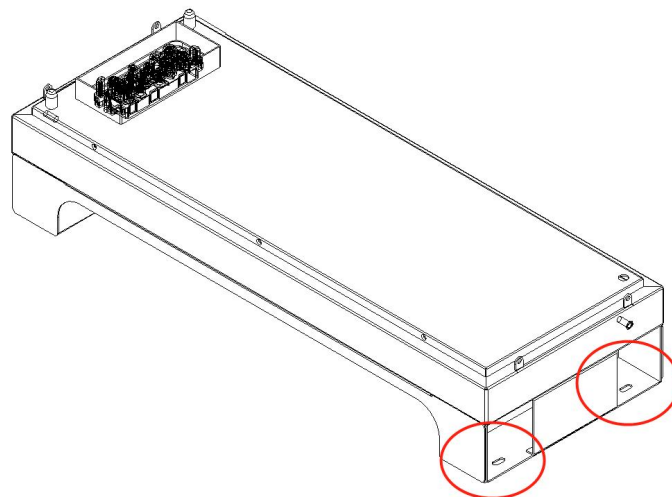

*Figure 3.1.2. Mounting position*

- 3) After securing the base, stack the remaining modules on top of each other. The main control unit must be placed in the uppermost layer. The sequence of the remaining modules is unaffected.

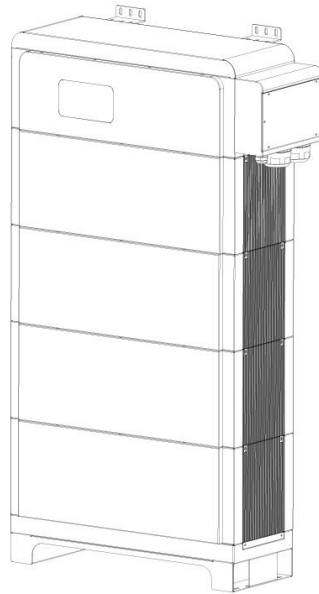

Figure 3.1.3. Battery

4) Use M4 screws to install the side panels of the modules as shown in the following figure. It should be noted that the base also has a base layer to install.

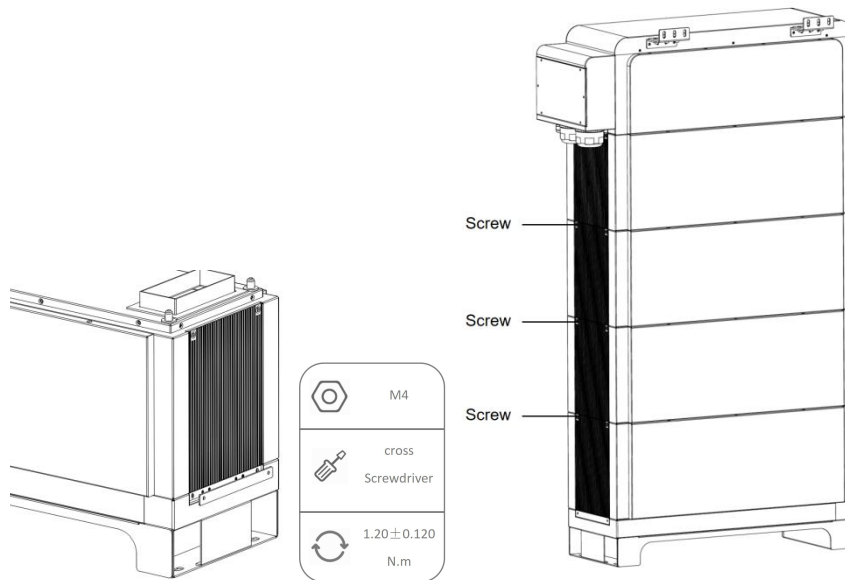

Figure 3.1.4. Base layer & Side panel

5) Install Mounting A and Mounting B on the back of the main control. Use M4 screws to secure Mounting A to the back of the main control, M6 screws to connect Mounting A to Mounting B.

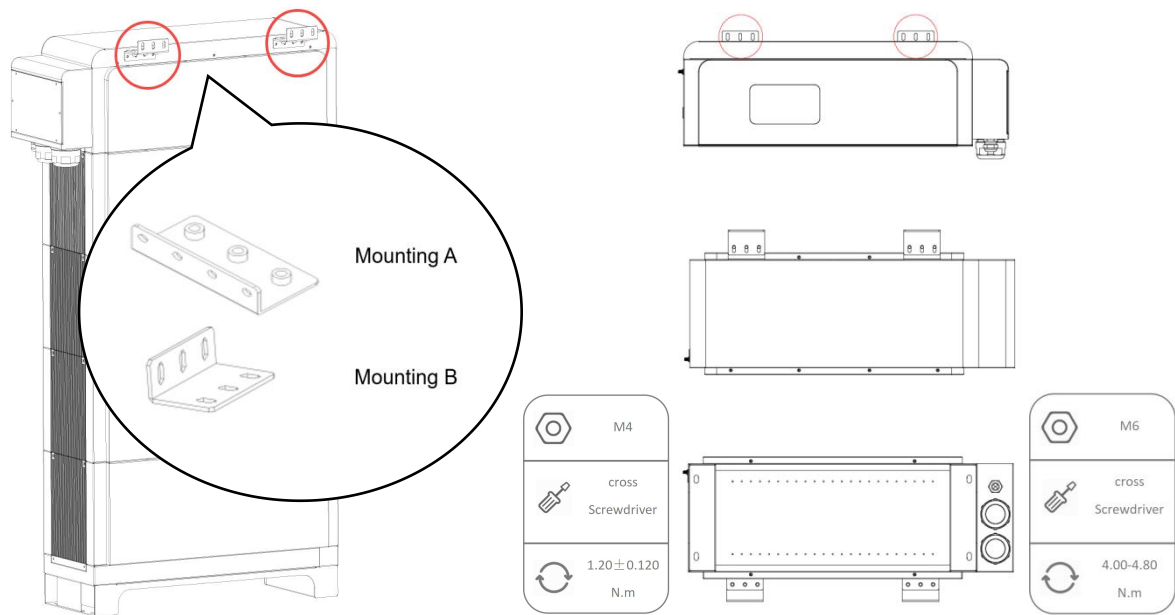

Figure 3.1.5. Mounting position & Master three views

6) Please first draw corresponding holes on the wall according to the position of the Mounting B behind the main control. Then drill holes and put them back on the main control, use Plastic expansion screw 10×60 with M6×60 flange 304 self-tapping screw to fix to the wall. At last, install the remaining side panels that connect to the main control.

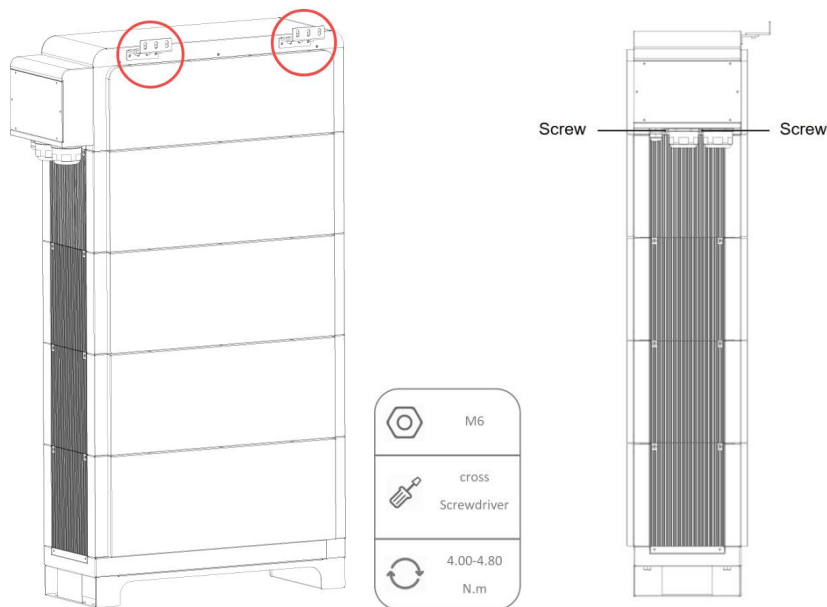

Figure 3.1.6. Mounting A position & Side panels connected to the main control

## 3.2 Connection

1) Remove the side cover panel of master to connect the cable.

This position is welded to the battery, only the side panel can be removed.

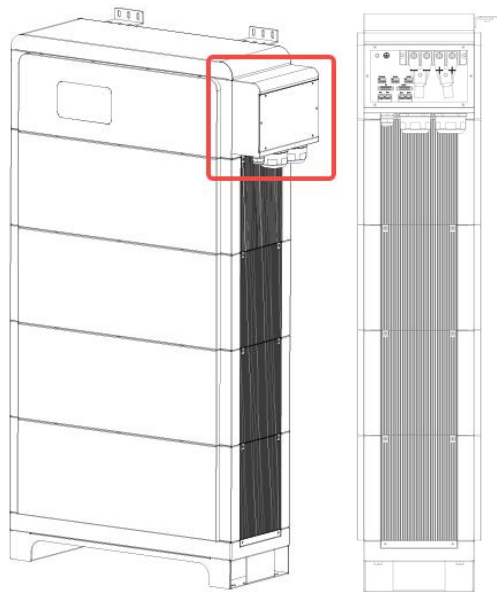

Figure 3.2.1. Side cover panel of master & Interface

2) Connect the ground wire as the diagram shows below.

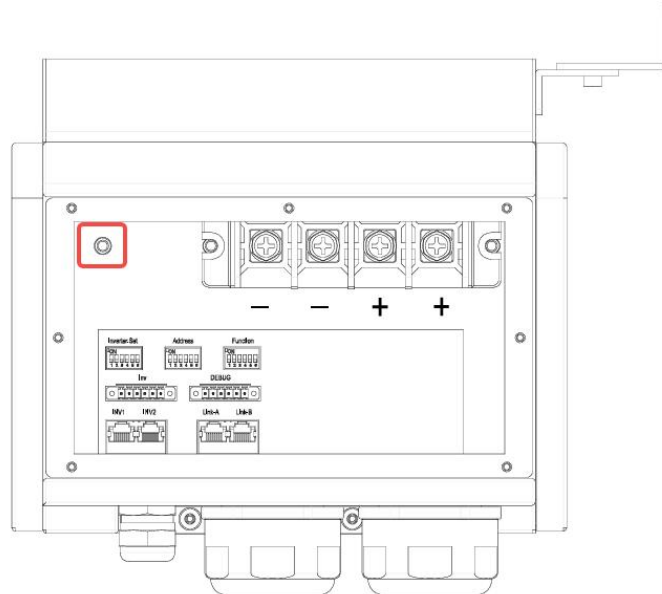

Figure 3.2.2. Grounding

3) Connect to inverter's negative and positive terminals.

Terminal type: 2/0 AWG

Torsion: 10N.m

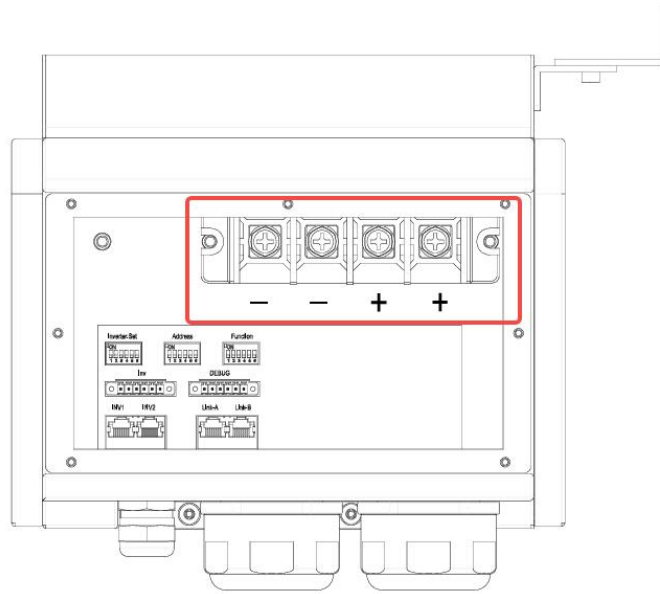

Figure 3.2.3. Positive & Negative

#### 4) Communication cable connection

Pay attention to the marked communication knockouts, you need to remove the knockouts first before install. The knockouts consists of three parts, respectively block shot, knockouts rubber pad and plastic parts.

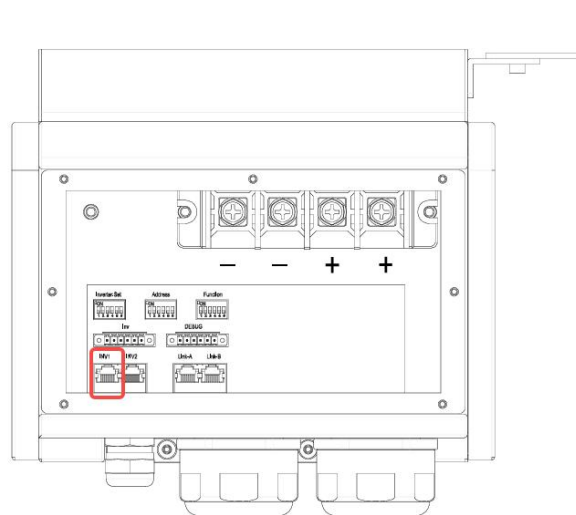

Figure 3.2.4. INV1 port

**Note:** Registered jack cannot go through the knockouts directly, please follow the steps below to install.

Step 1: Remove the block shot and fetch out the knockouts and rubber gasket.

Step 2: Gash the knockouts rubber pad follow the diagram to install communication cable.

Step 3: Install back to the original state in the order shown below after the communication cable goes through the knockouts.

Step 4: Simply tighten and install the three parts that have been sorted through the knockouts.

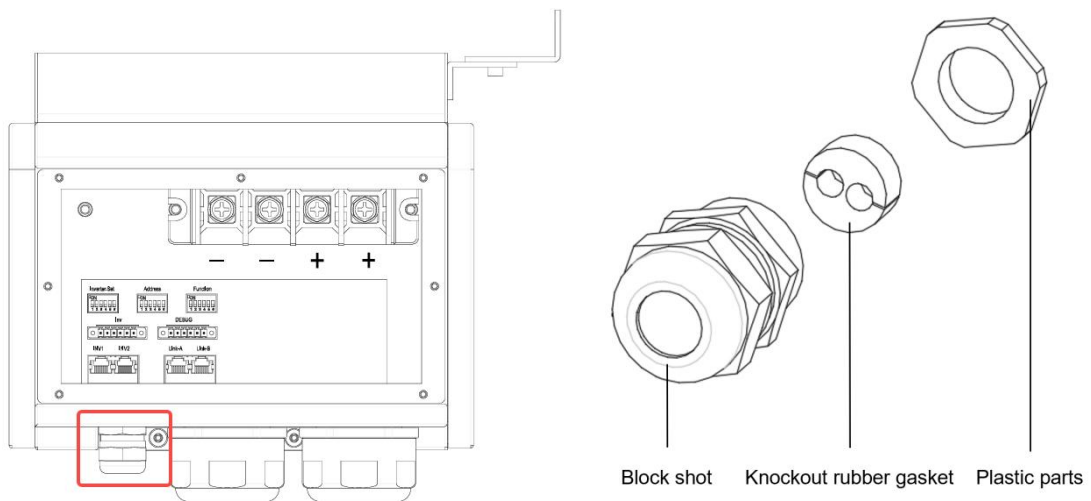

Figure 3.2.5. Communication cable connection & Knockouts parts

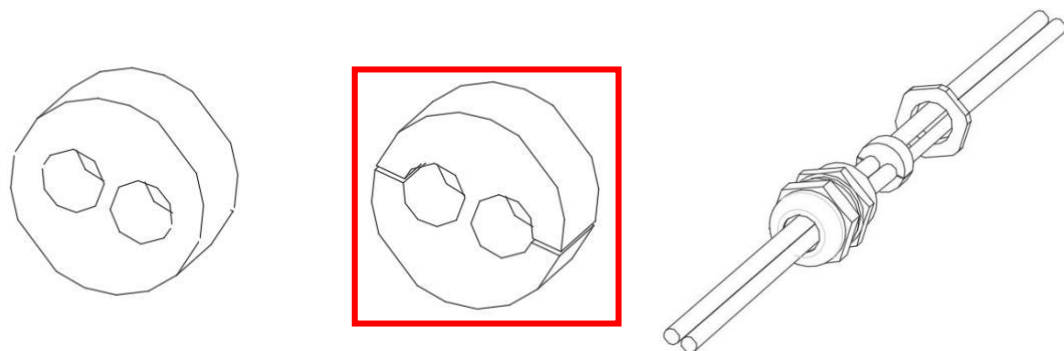

Figure 3.2.6. Knockout rubber gasket & Knockouts installation diagram

### 5) Dial code setting

Step 1: Please refer to the 5.4.3 Inverter Dial Switch for inverter configuration.

Step 2: Please refer to the 5.4.4 Address Dial Switch for address configuration.

Step 3: Please refer to the 5.4.5 Function Dial Switch for function configuration.

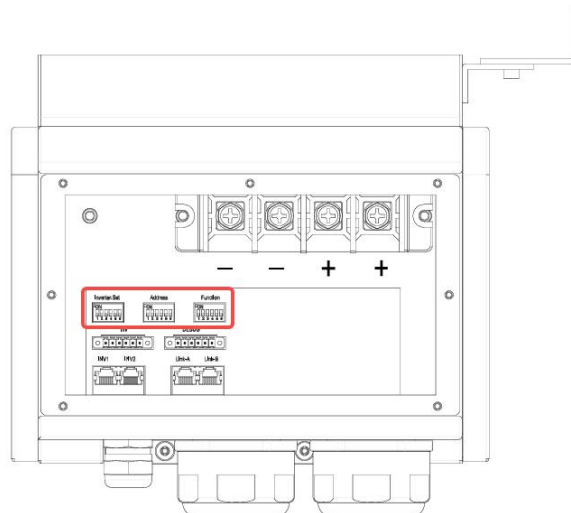

Figure 3.2.7. Dial code

### 3.3 Application Scenarios



#### 3.3.1 Single Stack

Step 1: Change the dial code of Inverter.Set, Address, and Function.

Step 2: Connect battery INV1 to inverter CAN Bus port.

Step 3: Connect the positive and negative terminal of the master to the positive and negative terminal of the slave using a 2\*2/0 AWG DC cable, and then connect the two cables together to the positive and negative terminal of the battery port.

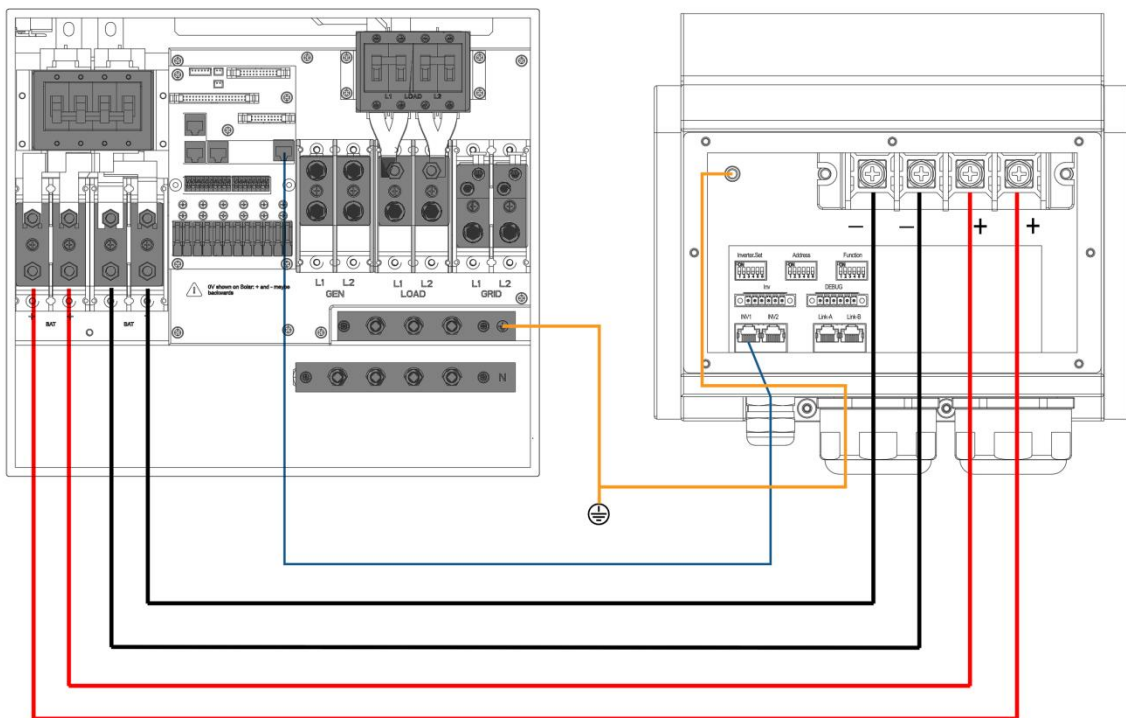

Figure 3.3.1. Connect with inverter

Example: Connect with Sol-Ark inverter.

|         | Address | Inverter | Function |
|---------|---------|----------|----------|
| Battery |         |          |          |

### 3.3.2 Parallel

Step 1: Change the dial code of Inverter.Set, Address, and Function.

Step 2: Connect Link-B of the master battery to Link-A of the slave battery.

Step 3: Connect battery INV1 to inverter CAN Bus port.

Step 4: Connect the positive and negative terminal of the master to the positive and negative terminal of the slave using a 2\*2/0 AWG DC cable, and then connect the two cables together with the positive and negative terminal of the battery port.

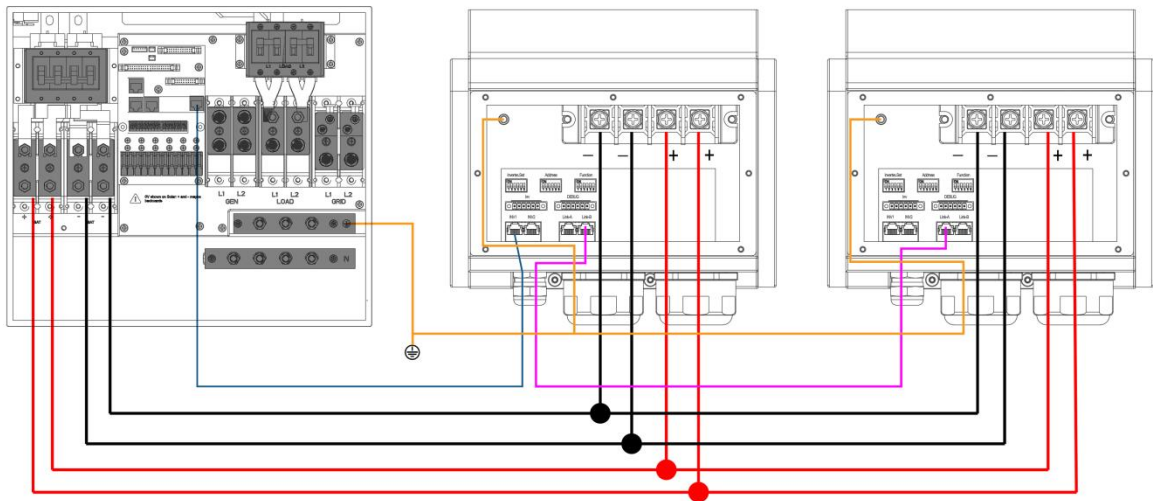

Figure 3.3.2. Diagram of two equipment in parallel

Example: Connect with Sol-Ark inverter.

|        | Address | Inverter | Function |
|--------|---------|----------|----------|
| Master |         |          |          |
| Slave  |         |          |          |

### 3.3.3 Precautions for Multiple Parallel Connections

1) Plan the distance between the two units and no less than 12 in (300mm), and 20 in (500mm) is recommended.

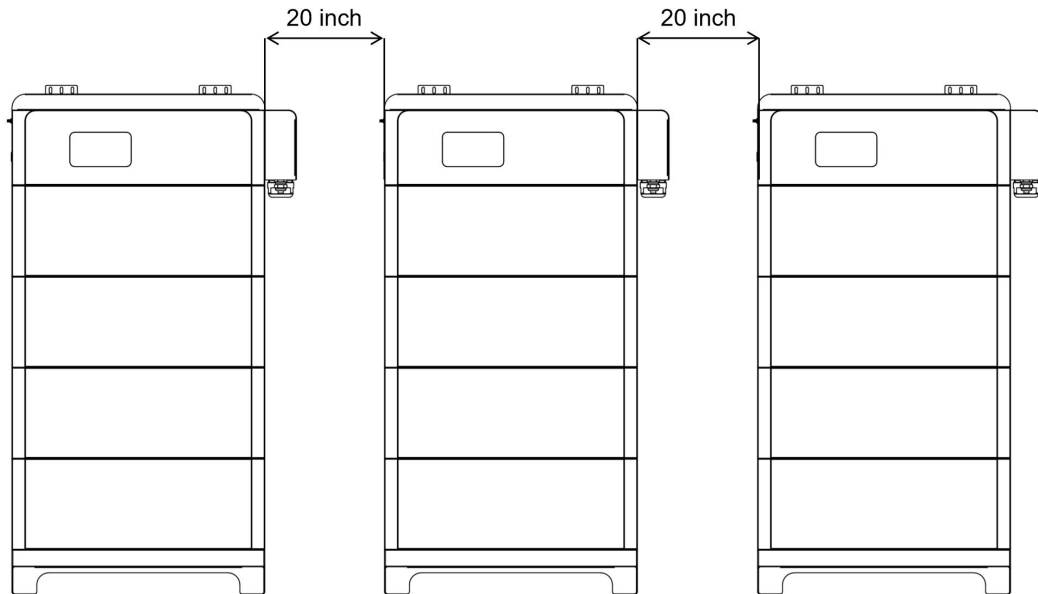

Figure 3.3.3. The distance between two adjacent battery stack

2) Before the parallel, every cluster's main controller needs to distinguish the number of battery modules for each cluster. Press the power button of each main controller. Listen for the beep sound which means the main controller has distinguished the number of battery modules are in the cluster successfully.

3) Turn off the system and then connect the positive and negative electrode of the cluster to busbar, the busbar must be able to withstand the maximum current of the system. Each main controller's address dial code should be set as 1,2, 3... in order.

4) Use parallel communication wire to connect with clusters. For instance, connect Link B of cluster 1 to Link A of cluster 2, and then connect Link B of cluster 2 to Link A of cluster 3, and so on.

**Note:** Multiple batteries in parallel require an additional busbar.

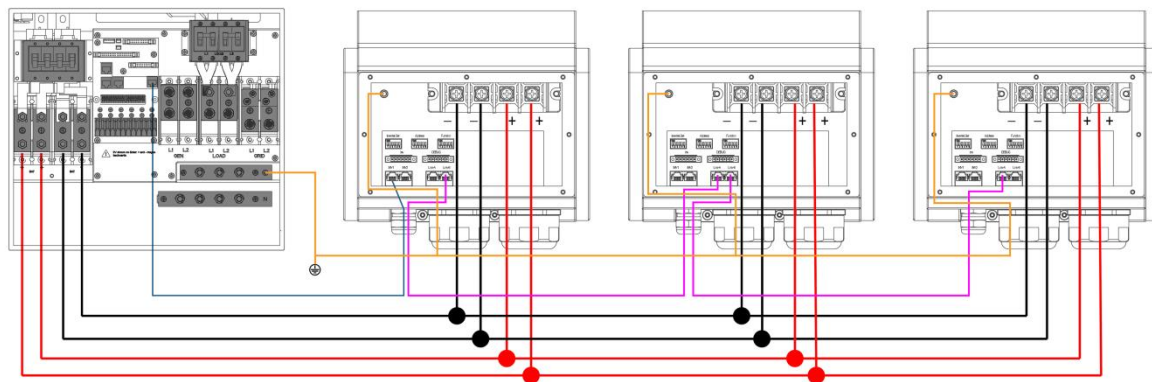

Figure 3.3.4. Diagram of multiple batteries in parallel

5) Set the first cluster and the last cluster of the system's function dial code as code 33 and set function dial code of remaining clusters to code 32.

Set the inverter dial switch according to the actual usage.

The address dial switch increases sequentially, please refer to the **5.4.4. Address Dial Switch** for details.

Example: Connect with Sol-Ark inverter.

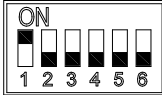
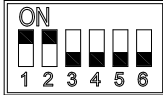
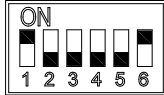
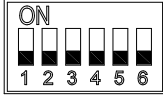
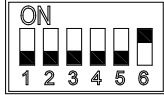
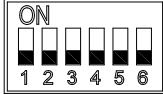
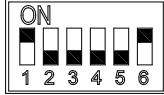
|           | Address   | Inverter   | Function   |
|-----------|---|--|--|
| Master    |  |   |   |
| Slave n   | ...   |   |   |
| Slave n+1 | ...   |  |  |

6) Make sure all clusters are turned on except first one. Turn on the first cluster to detect the number of clusters installed in parallel. After finishing this step, set the inverter dial code of the first cluster to the corresponding inverter's code. Only cluster 1 need to be connected to inverter by communication wire.

## 4 Cloud Platform Configuration

Screw the antenna into the antenna connection port firmly before WiFi configuration.

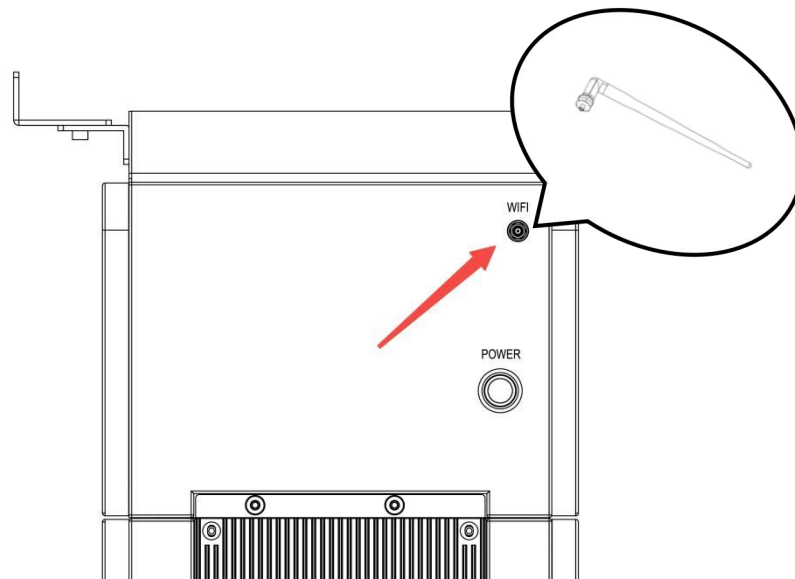

Figure 4.1.1. WiFi wiring position

### 1) Download App

Download and install Renon app from Google play or App Store by searching “Renon Smart”.



Figure 4.1.2. Install Renon App



Figure 4.1.3. Android QR code



Figure 4.1.4. IOS QR code



## 2) Register

For new account registration, please retrieve the Registration Code from your installer. Existing users may log in directly, while new users must create an account.

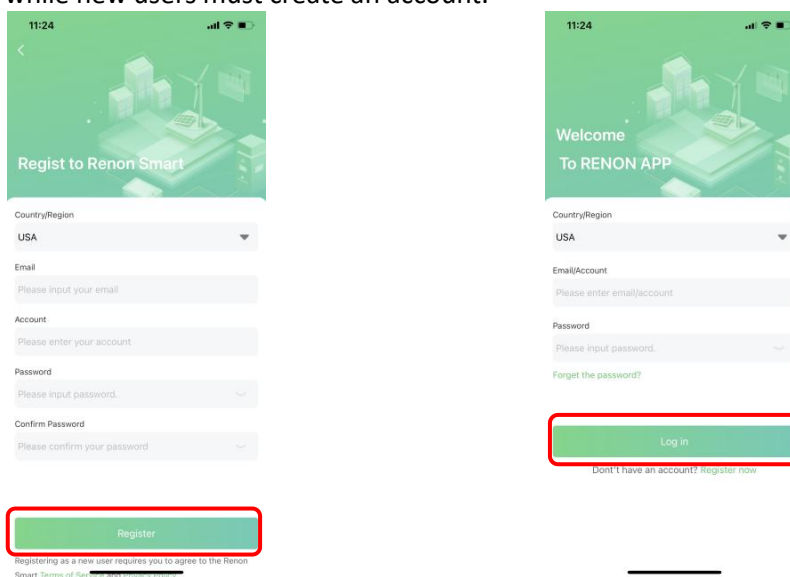

Figure 4.1.5. Register & Log in

## 3) Log in

This is a general user account.

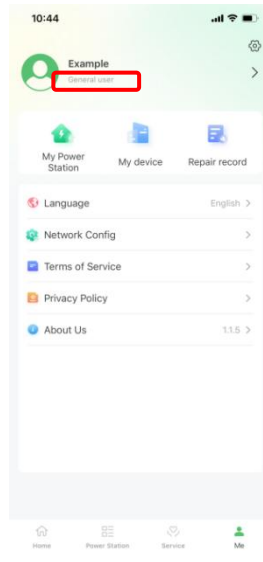

Figure 4.1.6. General user

#### 4) Binding

Merhod 1:

##### a. Distribution

To register as an end user, scan the binding QR code provided by your installer, then request device assignment to your account.

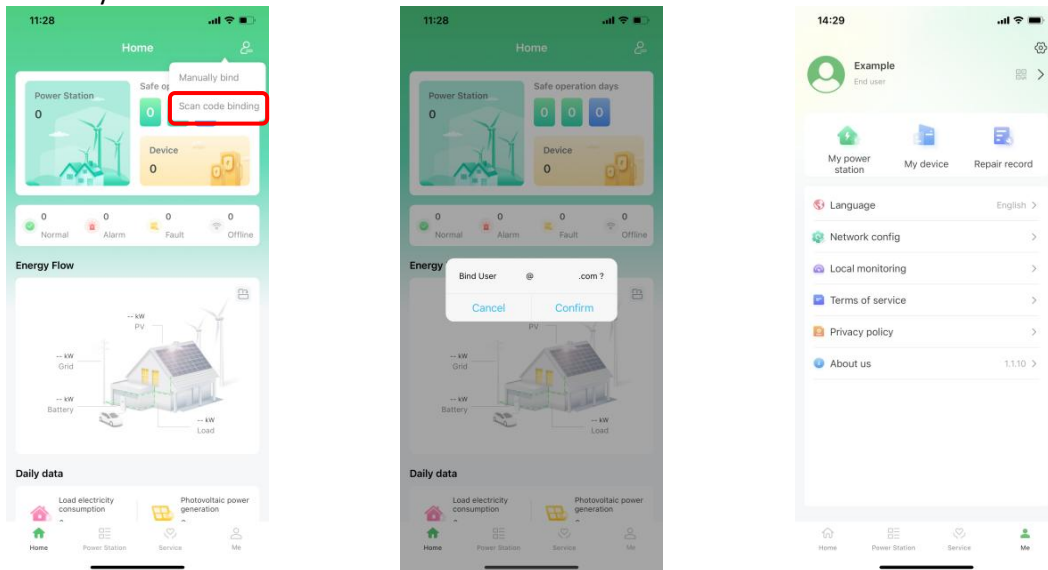

Figure 4.1.7. Scan upper-level account, Confirm binding & Become end user

##### b. Scan QR code

Select "Scan code binding" and scan the QR code using your device camera. Contact the installer if unsuccessful.

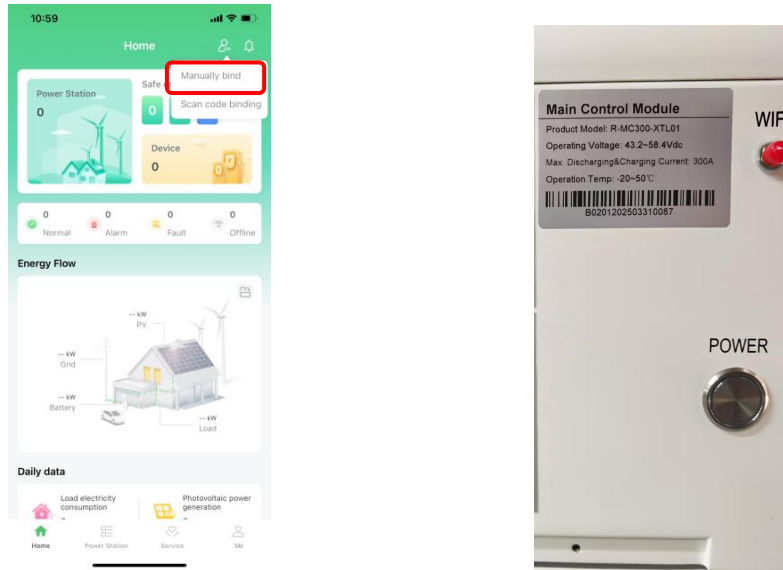

Figure 4.1.8. Scanning QR code

Method 2:

Click "My device" to enter the "Add a device" page, scan the QR code as illustrated, then select a upper-level account to complete binding.

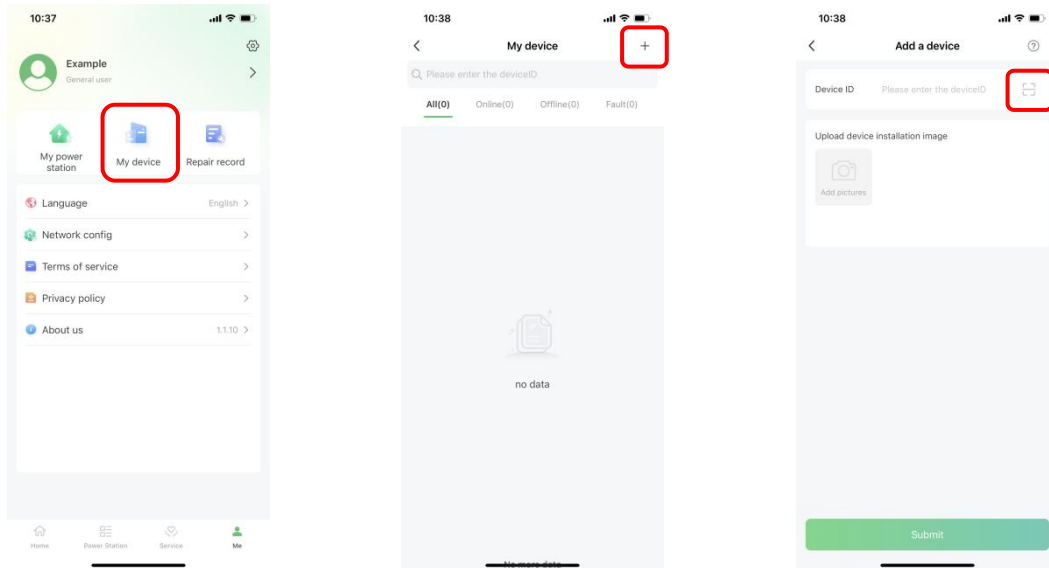

Figure 4.1.9. My device, add & scanning

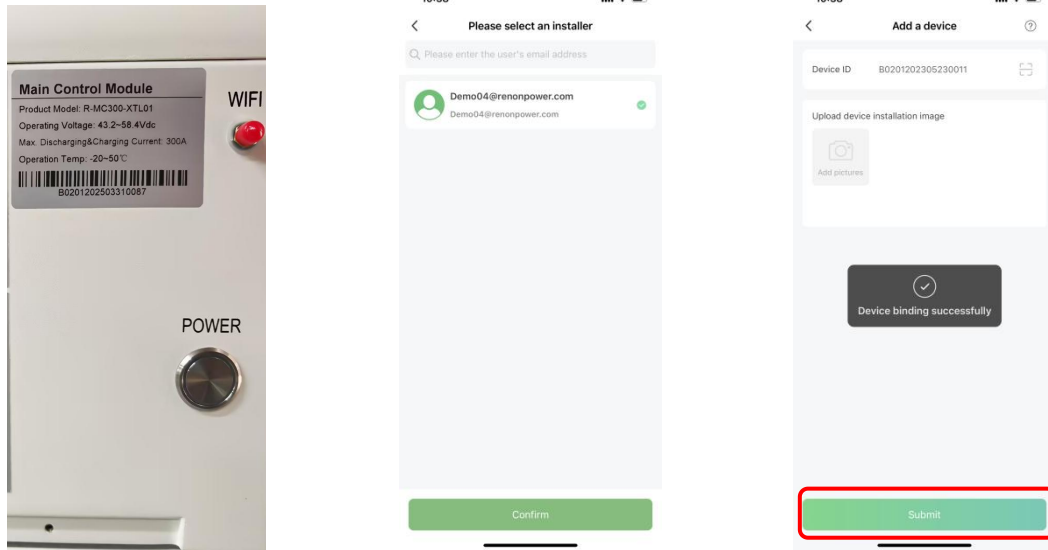

Figure 4.1.10. QR code, upper-level account & binding successfully

If the above methods are not successful, please contact Renon, email address: [support@renon-usa.com](mailto:support@renon-usa.com), Renon Power Support: +1 (833) 736-6687. Be sure to write your account name/email address and device serial number clearly.

## 5) WiFi configuration

Set the inverter dial code to 63 (111111) as shown below before WiFi configuration.

**Note:** In a system with multiple batteries operating in parallel, you only need to configure the master battery unit (set to Address 1). Once configured, all other units will automatically retrieve network settings and connect seamlessly without manual intervention.

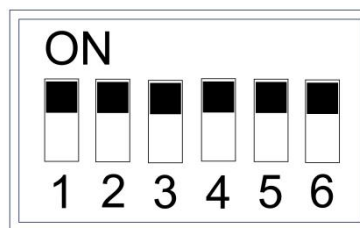

Turn to the “Me” page, click Network Configuration, then click Bluetooth, followed by WiFi configuration.

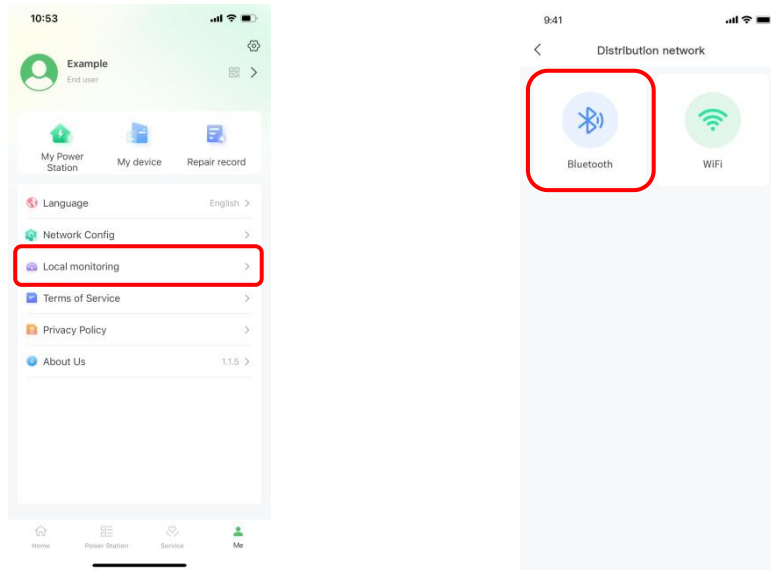

Figure 4.1.11. Bluetooth network setting

Enable Bluetooth on your mobile device, then select the detected device to access its Bluetooth network configuration page

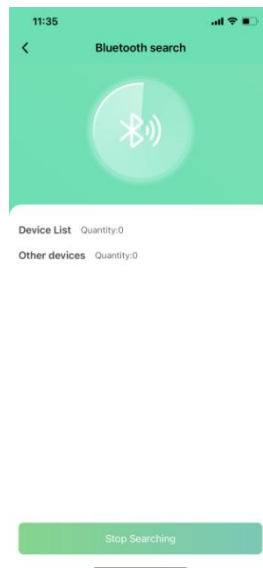

Figure 4.1.12. Connect battery Bluetooth

Enter your private WiFi credentials (SSID and password) to connect the master controller.

**Note:** Devices assigned to end users will auto-populate the authentication key.

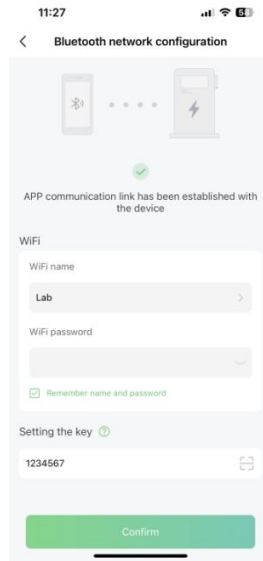

Figure 4.1.13. Connecting private WiFi

## 6) Create a power station

Navigate to the Power Station page on the app, create a new station by setting its name, type, pricing, superior view, address, and uploading station images.

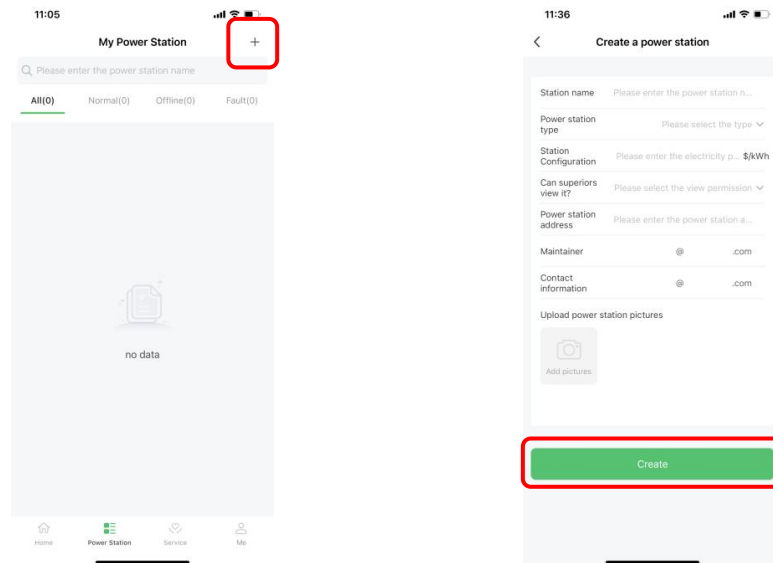

Figure 4.1.14. Create a new power station

After successful power station creation, select the newly created station to view its details, then tap "+" on the Binding Device page to add your desired device.

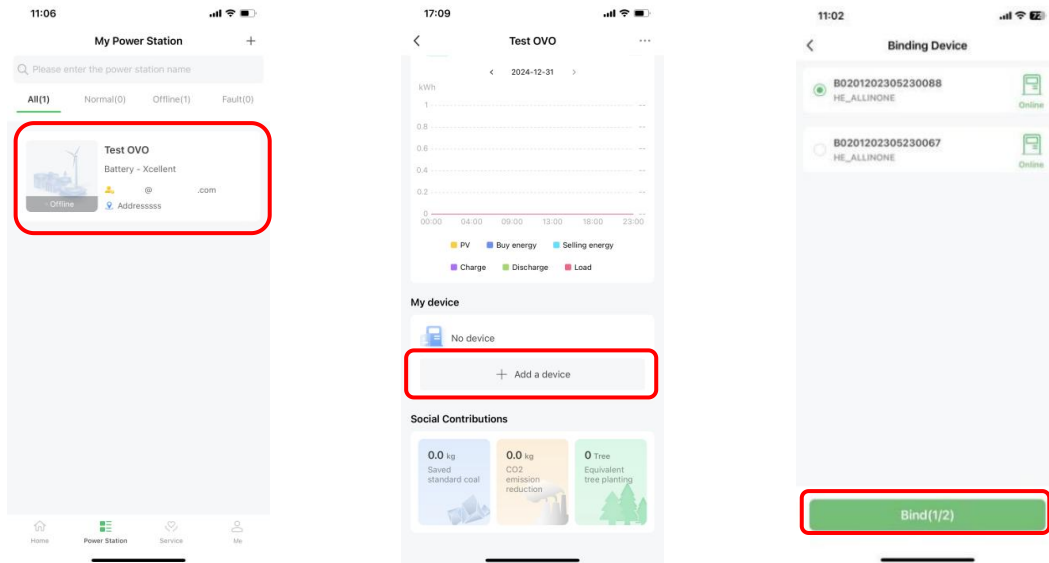

Figure 4.1.15. Manage your power station & Confirm your device

The device can be managed both through the app and the web portal (contact your installer for the website URL).

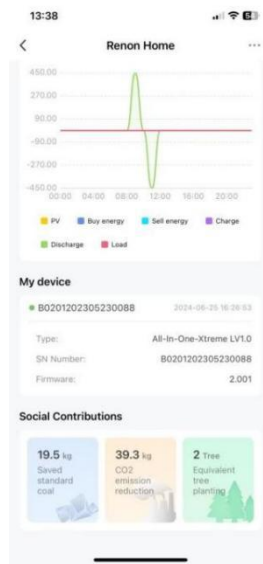

Figure 4.1.16. Manage your device

Once WiFi connected, the device enables real-time monitoring of operational status, instantaneous power, and energy consumption (daily/cumulative) via the network platform or mobile app, while also supporting remote parameter configuration.



Figure 4.1.17. Monitoring device

Set the inverter dial code to match the inverter brand after WiFi configuration is complete (Please refer to the chapter **5.4.3 Inverter Dial Switch**).

## 5 Battery Specifications

The Xtreme LV series is a lithium iron phosphate (LFP) battery-based energy storage product developed and produced by RENON, it can supply reliable power for nearly all kinds of household appliances and equipment.

The Xtreme LV series consists of a main controller and several battery modules, each battery module has a built-in BMS battery management system, which can manage and monitor cells information including voltage, and a DC-DC converter, current and temperature, used to limit the balance current between different batteries when parallel use.

Multiple battery stacks are allowed to be connected to expand capacity and power to meet the requirements of longer power supporting duration and higher power consumption.

### 5.1 Product Features

- With a DC-DC converter inside, users can extend or change battery modules whenever they want, no need to consider the quality or SOC of old modules.
- The whole product is non-toxic, pollution-free, and environment-friendly.
- The battery chemistry is made from LiFePO<sub>4</sub> with safety, performance, and a long cycle life.
- The battery is small in volume, has plug & play embedded design module, and is easy to install and maintain.
- Working temperature range is between -4°F and 122°F (-20°C to 50°C) with excellent discharge performance.
- The battery management system (BMS) has protection functions for over-discharge, over-charge, over-current, and high/low temperature.
- The battery can self-discharge up to 3 months without charging and offers excellent performance of shallow charge and discharge.
- The system can automatically manage battery charge and discharge state, and save energy costs with various automatic options.

## 5.2 Specifications

### 5.2.1 Specifications 1 (16 series cells)

| Item                                  | R-XL010021 (-H)  | R-XL015031 (-H)             | R-XL020041 (-H)             | R-XL025051 (-H)             | R-XL030061 (-H)             | R-XL035071 (-H)           | R-XL040081 (-H)             |
|---------------------------------------|--|-----------------------------|-----------------------------|-----------------------------|-----------------------------|---------------------------|-----------------------------|
| Controller Model                      | R-MC300-XTL01  |                             |                             |                             |                             |                           |                             |
| Battery Module Model                  | R-EM51100-XTL01 (-H)   |                             |                             |                             |                             |                           |                             |
| Battery Chemistry                     | LiFePO4  |                             |                             |                             |                             |                           |                             |
| Module Quantity                       | 2  | 3                           | 4                           | 5                           | 6                           | 7                         | 8                           |
| Nominal Energy (kWh)                  | 10.24  | 15.36                       | 20.48                       | 25.60                       | 30.72                       | 35.85                     | 40.96                       |
| Nominal Capacity (Ah)                 | 200  | 300                         | 400                         | 500                         | 600                         | 700                       | 800                         |
| Max. Charging/Discharging Current (A) | 190  | 285                         | 300                         | 300                         | 300                         | 300                       | 300                         |
| Nominal Voltage (V)                   | 51.2   |                             |                             |                             |                             |                           |                             |
| Recommend Charging Voltage (V)        | 56.8   |                             |                             |                             |                             |                           |                             |
| Max. Charging Voltage (V)             | 58.4   |                             |                             |                             |                             |                           |                             |
| Discharge Cut-off Voltage (V)         | 43.2   |                             |                             |                             |                             |                           |                             |
| Heating Film Resistance(Ω)            | 16 per module (-H model only)  |                             |                             |                             |                             |                           |                             |
| Heating Start Temperature (°F/°C)     | 41/5 (-H model only)   |                             |                             |                             |                             |                           |                             |
| Operation Temperature(°F/°C)          | Discharge: -4~122 / -20~50<br>Charge: 32~122 / 0~50  |                             |                             |                             |                             |                           |                             |
| Safety Function                       | Over-charge, Over-discharge, Over-current, Low/High-temperature, Short-circuit Protections |                             |                             |                             |                             |                           |                             |
| Parallel Capacity                     | Maximum 15 Clusters  |                             |                             |                             |                             |                           |                             |
| Communication                         | RS485/CAN/WiFi   |                             |                             |                             |                             |                           |                             |
| Weight (lbs/kg)(Approx.)              | 311/141  | 428/194                     | 545/247                     | 661/300                     | 778/353                     | 895/406                   | 1012/459                    |
| Physical Dimensions (in/mm)(W*D*H)    | 25.0*10.6*31.3/635*268*795   | 25.0*10.6*40.3/635*268*1023 | 25.0*10.6*49.2/635*268*1250 | 25.0*10.6*58.2/635*268*1478 | 25.0*10.6*67.1/635*268*1705 | 25.0*10.6*76/635*268*1932 | 25.0*10.6*84.9/635*268*2159 |
| Level of Protection                   | IP65   |                             |                             |                             |                             |                           |                             |
| Altitude                              | ≤4000m   |                             |                             |                             |                             |                           |                             |

## 5.2.2 Specifications 1 (15 series cells)

| Item                                  | R-XL009021 (-H)  | R-XL014031 (-H)             | R-XL019041 (-H)             | R-XL024051 (-H)             | R-XL028061 (-H)             | R-XL037071 (-H)           | R-XL046081 (-H)             |
|---------------------------------------|--|-----------------------------|-----------------------------|-----------------------------|-----------------------------|---------------------------|-----------------------------|
| Controller Model                      | R-MC300-XTL01  |                             |                             |                             |                             |                           |                             |
| Battery Module Model                  | R-EM48100-XTL01 (-H)   |                             |                             |                             |                             |                           |                             |
| Battery Chemistry                     | LiFePO4  |                             |                             |                             |                             |                           |                             |
| Module Quantity                       | 2  | 3                           | 4                           | 5                           | 6                           | 7                         | 8                           |
| Nominal Energy (kWh)                  | 9.6  | 14.4                        | 19.2                        | 24                          | 28.8                        | 33.6                      | 38.4                        |
| Nominal Capacity (Ah)                 | 200  | 300                         | 400                         | 500                         | 600                         | 700                       | 800                         |
| Max. Charging/Discharging Current (A) | 190  | 285                         | 300                         | 300                         | 300                         | 300                       | 300                         |
| Nominal Voltage (V)                   | 48   |                             |                             |                             |                             |                           |                             |
| Recommend Charging Voltage (V)        | 53.25  |                             |                             |                             |                             |                           |                             |
| Max. Charging Voltage (V)             | 54.75  |                             |                             |                             |                             |                           |                             |
| Discharge Cut-off Voltage (V)         | 40.5   |                             |                             |                             |                             |                           |                             |
| Heating Film Resistance(Ω)            | 16 per module (-H model only)  |                             |                             |                             |                             |                           |                             |
| Heating Start Temperature (°F/°C)     | 41/5 (-H model only)   |                             |                             |                             |                             |                           |                             |
| Operation Temperature(°F/°C)          | Discharge: -4~122 / -20~50<br>Charge: 32~122 / 0~50  |                             |                             |                             |                             |                           |                             |
| Safety Function                       | Over-charge, Over-discharge, Over-current, Low/High-temperature, Short-circuit Protections |                             |                             |                             |                             |                           |                             |
| Parallel Capacity                     | Maximum 15 Clusters  |                             |                             |                             |                             |                           |                             |
| Communication                         | RS485/CAN/WiFi   |                             |                             |                             |                             |                           |                             |
| Weight (lbs/kg)(Approx.)              | 308/139.5  | 424/192.5                   | 541/245.5                   | 658/298.5                   | 775/351.5                   | 894/404.5                 | 1009/457.5                  |
| Physical Dimensions (in/mm)(W*D*H)    | 25.0*10.6*31.3/635*268*795   | 25.0*10.6*40.3/635*268*1023 | 25.0*10.6*49.2/635*268*1250 | 25.0*10.6*58.2/635*268*1478 | 25.0*10.6*67.1/635*268*1705 | 25.0*10.6*76/635*268*1932 | 25.0*10.6*84.9/635*268*2159 |
| Level of Protection                   | IP65   |                             |                             |                             |                             |                           |                             |
| Altitude                              | ≤4000m   |                             |                             |                             |                             |                           |                             |

**Note:** -H indicates that this product contains a heating film and has a heating film function.

## **5.3 Function Introduction**

### **5.3.1 Protection**

The battery system is equipped with comprehensive protection features, including but not limited to overcharge/overdischarge protection, high/low temperature protection during charging/discharging, overcurrent protection during charging/discharging, and short circuit protection, ensuring the safety and stability of the battery under various usage conditions.

### **5.3.2 Heating**

When the battery is equipped with a heating film, the system will continuously monitor cell temperature. If the lowest cell temperature is below 41°F (5°C), the system will automatically activate the heating function to enhance battery performance. The heating function requires the inverter to be connected to the grid for continuous operation; otherwise, heating will only operate for 5 minutes. Once the highest cell temperature exceeds 59°F (15°C), the heating function will automatically deactivate to prevent overheating.

### **5.3.3 Forced Discharge**

When the system enters sleep mode due to undervoltage, users can manually activate the forced discharge mode by pressing the power button. Additionally, the system will automatically wake up at scheduled intervals to enter forced discharge mode, thereby activating the charger or inverter (the inverter requires grid connection) to provide necessary supplemental charging to the battery, ensuring its continued availability.

### **5.3.4 Full Charge**

To ensure long-term battery health, the system monitors the battery's charging status. If the system detects that the battery has not reached a full charge for 30 consecutive days, it will automatically initiate a full charge process, charging the battery to its maximum capacity to maintain optimal performance.

### **5.3.5 Charging Self-Adaptation Control**

The system will automatically reduce charging power when the battery is in low/high temperature conditions or low/high SOC.

### **5.3.6 Safety Lock**

This device is equipped with a safety lock function. If the lock is triggered and cannot be resolved after self-attempts, promptly contact technical support personnel for unlocking assistance.

## 5.4 Interface Information

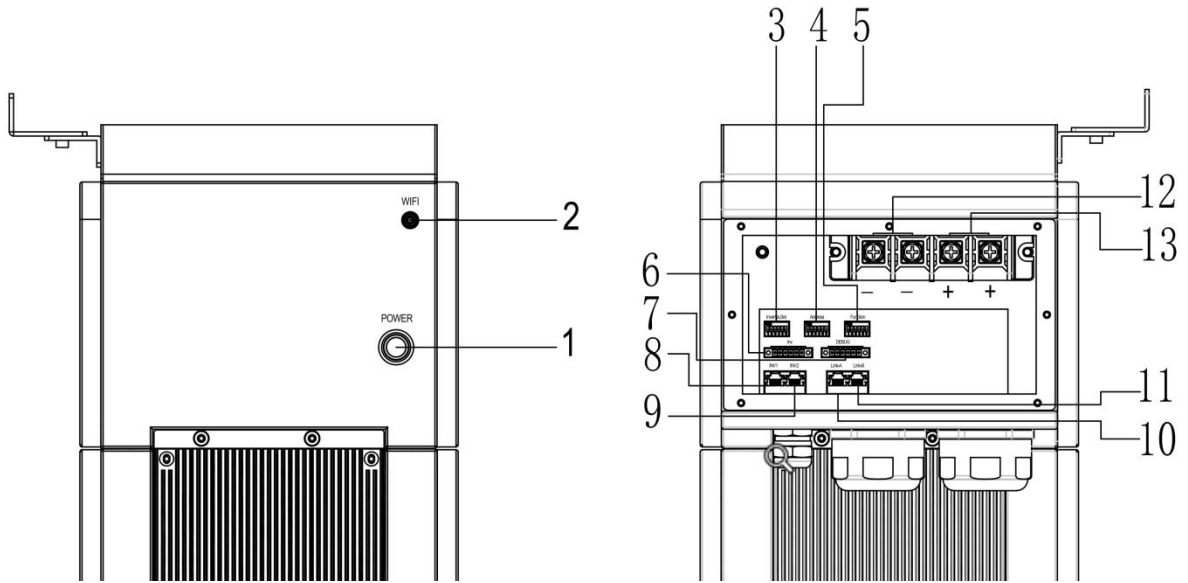

Figure 5.4.1. Interface definition of controller module

| No. | Instructions                            | No. | Instructions                         |
|-----|---|-----|--------------------------------------|
| 1   | Power Button                            | 8   | Inverter 1 Communication Port (RJ45) |
| 2   | WiFi Antenna Port                       | 9   | Inverter 2 Communication Port (RJ45) |
| 3   | Inverter Dial Switch                    | 10  | Parallel Communication Port A        |
| 4   | Address Dial Switch                     | 11  | Parallel Communication Port B        |
| 5   | Function Dial Switch                    | 12  | Power Negative                       |
| 6   | Inverter Communication Port (connector) | 13  | Power Positive                       |
| 7   | Debug                                   |     |                                      |

### 5.4.1 Power Button

Press this button once to power on the system, and press it again to power off.











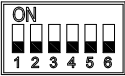

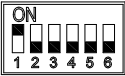

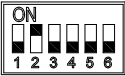









### 5.4.2 WiFi Antenna Port7

Connect the WiFi antenna to the port in order to get the APP and WEB connection.

### 5.4.3 Inverter Dial Switch

Code 0~26 of this Dial Switch are used to match which brand of inverter is using.















The definitions of code 0 ~ 26 are shown as below table.

| Code | Dial Switch Position  | Brand                             | Logo  |
|------|---|-----------------------------------|---|
| 0    |    | APP setting (Default: Renon Flex) |    |
| 1    |    | Renon                             |    |
| 2    |    | Schneider Gateway                 |    |
| 3    |   | Sol-Ark                           |   |
| 4    |  | Solis                             |  |
| 6    |  | Studer Xtender                    |  |
| 7    |  | Victron                           |  |
| 8    |  | SMA                               |  |
| 9    |  | Sermatec                          |  |
| 10   |  | Sofar                             |  |
| 11   |  | DEYE                              |  |
| 12   |  | Growatt SPF                       |  |

|    |   |                 |   |
|----|---|-----------------|---|
| 13 |    | Growatt SPH     |    |
| 14 |    | Must            |    |
| 15 |    | MEGAREVO        |    |
| 16 |    | SAJ             |    |
| 17 |    | Aiswei          |    |
| 18 |    | Phocos          |    |
| 22 |    | Voltronic Power |    |
| 24 |   | Afore           |  |
| 25 |  | Lux Power       |  |
| 26 |  | CHISAGE ESS     |  |

#### 5.4.4 Address Dial Switch



- 1) Use this Dial Switch to set the address of each master controller, and then turn on to activate the system when it needs to be in parallel with other stacked units.
- 2) When the system only has one stack, dial the address to Cluster 1.
- 3) When the system is used in parallel mode, set the address start from 1, and increase by the number of stacked units in order to communicate with other stacks.
- 4) The illustration of dialing shown below:

| Code | Dial Switch Position  | Definition   |
|------|---|--|
| 1    |    | Set as Cluster 1 (communicate with inverter by this cluster) |
| 2    |    | Set as Cluster 2   |
| 3    |    | Set as Cluster 3   |
| 4    |    | Set as Cluster 4   |
| 5    |    | Set as Cluster 5   |
| 6    |    | Set as Cluster 6   |
| 7    |    | Set as Cluster 7   |
| 8    |   | Set as Cluster 8   |
| 9    |  | Set as Cluster 9   |
| 10   |  | Set as Cluster 10  |
| 11   |  | Set as Cluster 11  |
| 12   |  | Set as Cluster 12  |
| 13   |  | Set as Cluster 13  |
| 14   |  | Set as Cluster 14  |
| 15   |  | Set as Cluster 15  |

#### 5.4.5 Function Dial Switch

Use this dial switch to match the communication impedance:

Optimize and enhance the communication between the master control unit and the battery so as to communicate between paralleled clusters.

| Code | Dial Code Switch Position   | Definition  |
|------|---|---|
| 32   |  | <ul style="list-style-type: none"> <li>① When used as single cluster;</li> <li>② When used in a parallel system and not being the first or last cluster.</li> </ul> |
| 33   |  | <ul style="list-style-type: none"> <li>① When used as the first or last cluster in a parallel system.</li> </ul>  |

#### 5.4.6 Inverter Communication Port

Terminal type: 6-Pin terminal block

Usage: reserved for direct connection with inverter, same function as the RJ45 port (chapter " **INVERTER 1 Port (RJ45)**"), either one of these two can be used.

Defined as below:

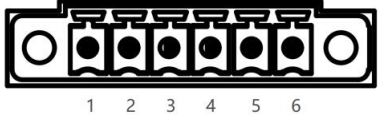
| 6pin Terminal   | Pin | Usage      |
|---|-----|------------|
|  | 1   | RS485_2A   |
|   | 2   | RS485_2B   |
|   | 3   | RS485_2GND |
|   | 4   | CAN2GND    |
|   | 5   | CAN2L      |
|   | 6   | CAN2H      |

#### 5.4.7 Debug Port

Terminal type: 6-Pin terminal block

Usage: reserved for our technical to debug.

Defined as below:

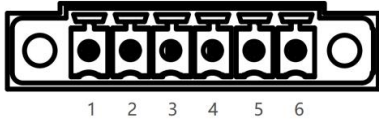
| 6pin Terminal   | Pin | Usage      |
|---|-----|------------|
|  | 1   | DIN+       |
|   | 2   | DIN-       |
|   | 3   | BAT_SW_IN  |
|   | 4   | BAT_SW_OUT |
|   | 5   | CAN1H      |
|   | 6   | CAN1L      |

### 5.4.8 INVERTER 1 Port (RJ45)

Terminal type: RJ45

Usage: Communicates with inverter, PCS, or other equipment.

Installer needs to check the cable pin out before connecting inverter to the battery in order to ensure communication.

Illustration of battery connection port shown below:

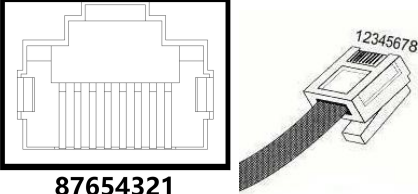
| Port  | RJ45 Pin | Function |
|---|----------|----------|
|  | 1        | RS485_2B |
|   | 2        | RS485_2A |
|   | 3        | SGND     |
|   | 4        | SGND     |
|   | 5        | SGND     |
|   | 6        | SGND     |
|   | 7        | CAN2H    |
|   | 8        | CAN2L    |

### 5.4.9 INVERTER 2 Port (RJ45)

Terminal type: RJ45

Usage: Communication with inverter internet port in order to upload inverter data to our platform.

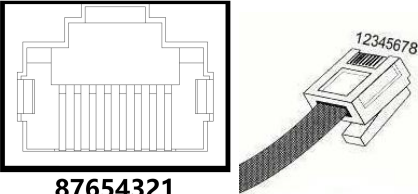
| Port  | RJ45 Pin | Function  |
|---|----------|-----------|
|  | 1        | RS485_2B  |
|   | 2        | RS485_2A  |
|   | 3        | SGND      |
|   | 4        | RS232RIN1 |
|   | 5        | RS232OUT1 |
|   | 6        | SGND      |
|   | 7        | RS485_2B  |
|   | 8        | RS485_2A  |

#### 5.4.10 Parallel Communication Port A & B

Terminal type: RJ45 \*2

Usage: Link A & Link B are parallel communication ports with the same definition. When more than one cluster is connected in parallel, use these ports to connect the clusters one by one.

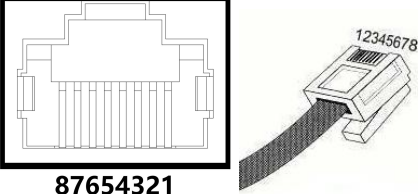
| Port  | RJ45 Pin | Function |
|---|----------|----------|
|  | 1        | CAN2L    |
|   | 2        | CAN2H    |
|   | 3        | CAN2GND  |
|   | 4        | CAN2GND  |
|   | 5        | CAN2GND  |
|   | 6        | CAN2GND  |
|   | 7        | CAN2H    |
|   | 8        | CAN2L    |

#### 5.4.11 Power Negative & Positive

Power terminal information for details shown below:

| OT terminal | Screw | Torsion | Wire diameter |
|-------------|-------|---------|---------------|
| SC120-8     | M8    | 10N.m   | 4/0 AWG       |
| SC70-8      | M8    | 10N.m   | 2/0 AWG       |

#### 5.4.12 Dial Code Switch

- 1) Set the Address dial code as 1 and set the function dial code as 32 in binary formation.

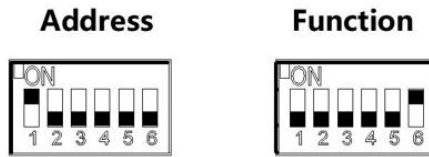

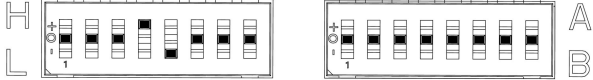









Figure 5.4.2. Dial code

2) Remove the cover of the positive and the negative electrodes. Connect the battery positive and negative electrodes with the inverter's positive and negative electrodes separately.

3) Connect CAN/RS485 wire to the inverter port of the master controller and inverter's CAN/RS485 port.

If you are using the pin order select box, please refer to the table below to set the dial switch according to the inverter brand. If the inverter brand is not shown in the table, please refer to the inverter manual or consult Renon's engineer.

| Dial Switch Position |           | Inverter          | Comm Mode |
|----------------------|-----------|-------------------|-----------|
| <br>CAN              | <br>RS485 | Schneider_Gateway | CAN       |
| <br>CAN              | <br>RS485 | Sol-Ark           | CAN       |
| <br>CAN              | <br>RS485 | Solis             | CAN       |
| <br>CAN              | <br>RS485 | Studer            | CAN       |
| <br>CAN              | <br>RS485 | Victron           | CAN       |
| <br>CAN              | <br>RS485 | SMA               | CAN       |

|   |                 |       |
|---|-----------------|-------|
|  <p>CAN      RS485</p>   | Sermatec        | CAN   |
|  <p>CAN      RS485</p>   | Sofar           | CAN   |
|  <p>CAN      RS485</p>   | DEYE            | CAN   |
|  <p>CAN      RS485</p>   | Growatt_SPF     | RS485 |
|  <p>CAN      RS485</p>   | Growatt_SPH     | CAN   |
|  <p>CAN      RS485</p> | Must            | CAN   |
|  <p>CAN      RS485</p> | MEGAREVO        | CAN   |
|  <p>CAN      RS485</p> | SAJ             | CAN   |
|  <p>CAN      RS485</p> | Aiswei          | CAN   |
|  <p>CAN      RS485</p> | Phocos          | RS485 |
|  <p>CAN      RS485</p> | Voltronic Power | RS485 |

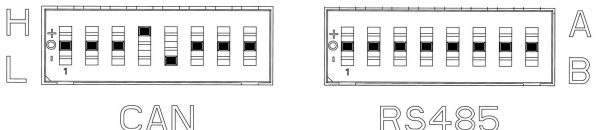
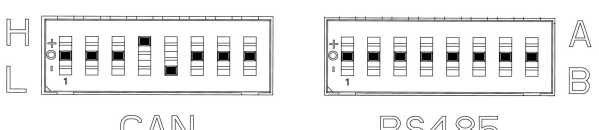
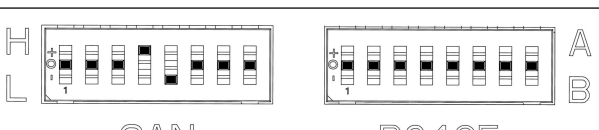
|   |             |     |
|---|-------------|-----|
|  <p>CAN      RS485</p> | Afore       | CAN |
|  <p>CAN      RS485</p> | Lux Power   | CAN |
|  <p>CAN      RS485</p> | CHISAGE ESS | CAN |

### 5.5 LCD Screen

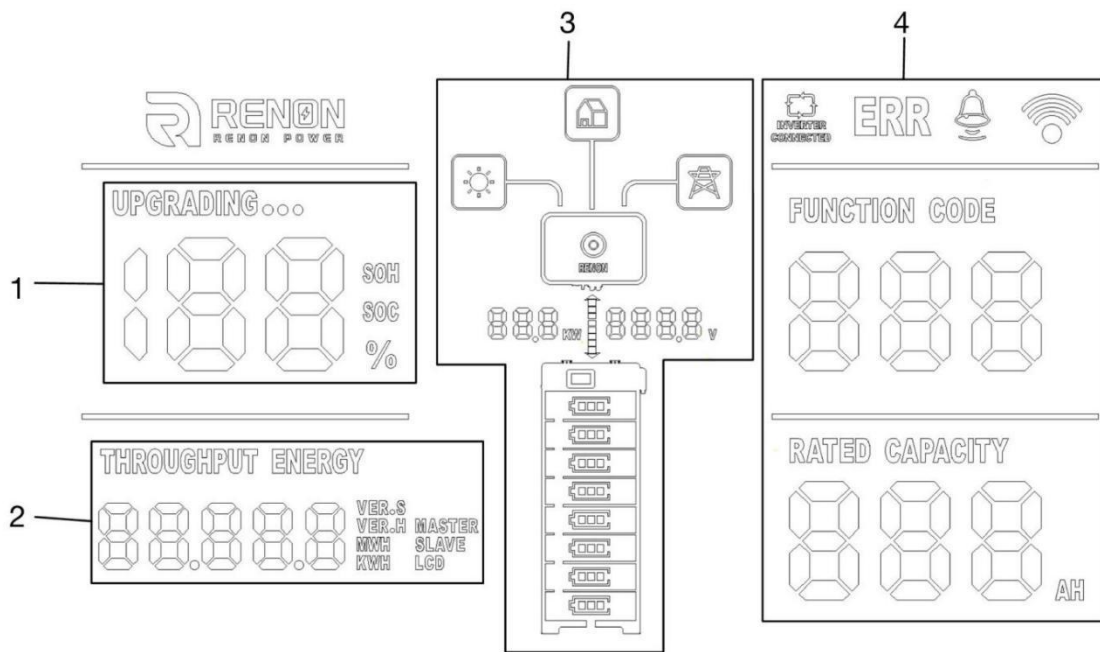

Figure 5.5.1 LCD Screen introduction

| No. | Instructions                             |
|-----|--|
| 1   | SOC, SOH and Upgrading State             |
| 2   | Version and Accumulated Discharge Energy |
| 3   | ESS status, Power, and Voltage           |
| 4   | Battery Operation State                  |

### 5.5.1 SOC, SOH and Upgrading State

1) The SOC percentage displays when the SOC symbol displays a light underneath, and the current SOH when there is a blinking light underneath SOH. The SOC lights up in 60 second intervals, and the SOH lights up in 3 second intervals.

2) The “UPGRADING ...” icon will show up when the battery is performing an upgrade. The percentage indicates the progress of the upgrade.

### 5.5.2 Version and Accumulated Discharge Energy

The number show the version of software and hardware for LCD, master, slave, and accumulated discharged energy in kWh or MWh, respectively. Each item will be displayed in 3 second intervals.

### 5.5.3 ESS Status, Power, and Voltage

1) This number displays current power and voltage of the complete battery stack. Direction of the arrow between those two numbers indicates if it’s charging or discharging.

2) The battery module icons will indicate the number of battery modules. Online modules will have lights on constantly while offline modules will blink periodically.

### 5.5.4 Battery Operation Status

#### 1) Indication Code

If there is any error or warning sign, the Indication Code will show up. When the Indication Code displays “ERR”, it means there an error has occurred. The Indication Code displays “

#### 2) Inverter Connection

“INVERTER CONNECTION” indicates the status of the connection between inverter and battery. It will display when proper connection is detected. Otherwise, it will be off.

#### 3) WiFi Connection Symbol

The WiFi icon will display as long as the WiFi connection is sufficient. It will blink periodically when the WiFi configured for the battery cannot connect to the server. Off means the battery is waiting for WiFi configuration.

| No. | Status                    | Instructions |
|-----|---------------------------|--------------|
| 1   | Cloud platform connection | Light on     |
| 2   | WiFi connection           | Flashing     |
| 3   | Not connection            | Light off    |

#### 4) Rated Capacity

Rated Capacity indicates the nominal capacity of current cluster.

#### 5.5.5 Screen Display Code

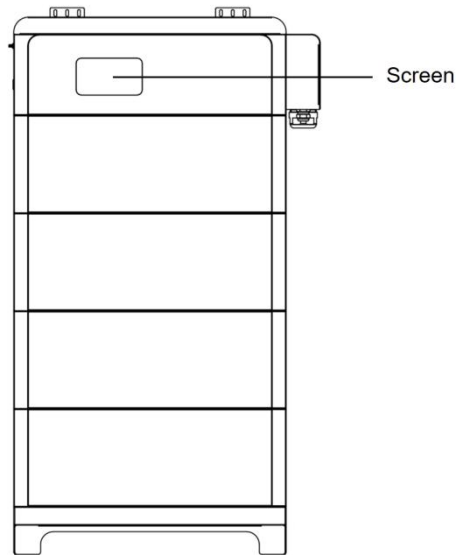

Figure 5.5.2 Screen

*Note: If the following fault codes are not displayed on the screen, the device will operate as intended.*

Warning Code (Sign like "🔔" )

| No. | Code | Warning Type                         |
|-----|------|--------------------------------------|
| 1   | 1    | Battery cell undervoltage protection |
| 2   | 2    | Overcurrent charge protection        |
| 3   | 3    | Overcurrent discharge protection     |
| 4   | 4    | High charge temp protection          |

|    |     |  |
|----|-----|--|
| 5  | 5   | High discharge temp protection                     |
| 6  | 6   | Low charge temp protection                         |
| 7  | 7   | Low discharge temp protection                      |
| 8  | 8   | High ambient temp protection                       |
| 9  | 9   | Excessive voltage difference protection            |
| 10 | 10  | Excessive temp of main control relay               |
| 11 | 11  | Overtemp protection of master DC busbar            |
| 12 | 12  | Low insulation resistance protection               |
| 13 | 13  | Low total voltage protection                       |
| 14 | 14  | Low ambient temp protection                        |
| 15 | 15  | High MOS temp protection                           |
| 16 | 16  | Battery cell overvoltage protection                |
| 17 | 17  | High total voltage protection                      |
| 18 | 18  | Low SOC protection                                 |
| 19 | 19  | Overcurrent discharge 2 protection                 |
| 20 | 22  | Positive connector high temp protection            |
| 21 | 23  | Negative connector high temp protection            |
| 22 | 24  | Relay high temp protection                         |
| 23 | 25  | Positive high temp protection for docking terminal |
| 24 | 26  | Negative high temp protection for docking terminal |
| 25 | 27  | Positive high temp protection for discharge port   |
| 26 | 28  | Negative high temp protection for discharge port   |
| 27 | 30  | Charger overvoltage protection                     |
| 28 | 400 | PCS disconnect (All-in-one only)                   |

Error Code (Display as "ERR" )

| No. | Code | Error Type   |
|-----|------|--|
| 1   | 100  | The main control discharge relay is faulty         |
| 2   | 101  | The main control charge relay is faulty            |
| 3   | 102  | Battery cell fault                                 |
| 4   | 103  | NTC fault  |
| 5   | 104  | Current sensor fault                               |
| 6   | 105  | Pack disconnection                                 |
| 7   | 106  | Short circuit fault                                |
| 8   | 107  | Internal total voltage detection fault             |
| 9   | 108  | Heating fault                                      |
| 10  | 109  | Battery module conflict                            |
| 11  | 110  | Cluster address conflict                           |
| 12  | 111  | Charge MOS fault                                   |
| 13  | 112  | Discharge MOS fault                                |
| 14  | 113  | Addressing failure                                 |
| 15  | 114  | Precharge fault                                    |
| 16  | 115  | Cluster disconnection                              |
| 17  | 116  | Battery reverse connection fault                   |
| 18  | 117  | External total voltage detection fault             |
| 19  | 118  | Address non-1 fault                                |
| 20  | 119  | Address break-sign failure                         |
| 21  | 123  | Microelectronic fault                              |
| 22  | 124  | Smoke sensor fault                                 |
| 23  | 125  | The number of slave voltage strings does not match |
| 24  | 126  | Temp NTC short circuit of master relay             |
| 25  | 127  | Temp NTC open circuit of master relay              |
| 26  | 128  | Temp NTC short circuit of master DC busbar         |



|    |     |   |
|----|-----|---|
| 27 | 129 | Temp NTC open circuit of master DC busbar |
| 28 | 130 | Master drop-off fault                     |
| 29 | 132 | EMS SN is empty                           |
| 30 | 133 | Master SN is empty                        |
| 31 | 134 | Pack SN is empty                          |
| 32 | 136 | Relay voltage fault                       |
| 33 | 200 | Battery cell undervoltage safety lock     |
| 34 | 201 | Battery cell high voltage safety lock     |
| 35 | 202 | Charge high temp safety lock              |
| 36 | 203 | Charge low temp safety lock               |
| 37 | 204 | Discharge high temp safety lock           |
| 38 | 205 | Discharge low temp safety lock            |
| 39 | 206 | Charge overcurrent safety lock            |
| 40 | 207 | Discharge overcurrent safety lock         |

## 6 Troubleshooting & Maintenance

### 6.1 Regular Maintenance

- 1) Check the battery modules every 3 months to verify whether there are damages.
- 2) Check the battery modules every 3 months to verify that the operating parameters are normal and there is no abnormal heating.
- 3) Fully charge and discharge the battery system every 3 months.
- 4) Clean the battery modules with a dry rag once a month.

### 6.2 Troubleshooting

| Phenomenon   | Investigation & troubleshooting   |
|--|---|
| <p>The number of battery module symbol is incorrect.</p>                                 | <ol style="list-style-type: none"> <li>1. Make sure the whole battery system is stacked neatly;</li> <li>2. Try to restart the battery system.</li> </ol>   |
| <p>The symbol of battery modules on the screen is blinking (frequency of 1s)</p>        | <ol style="list-style-type: none"> <li>1. Make sure the whole battery system is stacked neatly;</li> <li>2. Make sure the function dial switch code setting is correct, please refer to chapter "function dial switch";</li> <li>3. Try to restart the battery system.</li> </ol> |
| <p>The symbol of battery modules on the screen is rapid blinking (frequency of 2s)</p>  | <ol style="list-style-type: none"> <li>1. Try to charge and discharge the battery system for a cycle.</li> </ol>  |
| <p>Unable to turn on the battery</p>   | <ol style="list-style-type: none"> <li>1. Try to charge the battery with the activation charging function on the inverter when power is on.</li> </ol>  |

|   |   |
|---|---|
| <p>Unable to find the battery on the app or the Cloud</p> | <ol style="list-style-type: none"> <li>1. Make sure the WiFi antenna is tightened screwed properly;</li> <li>2. Make sure the WiFi configuration is correct;</li> <li>3. Make sure the SSID &amp; PASSWORD of your private WiFi is correct, please enter information case-sensitively without space;</li> <li>4. Make sure the WiFi signal is strong enough;</li> <li>5. Make sure WiFi is working;</li> <li>6. Make sure installer has added your products to your account;</li> <li>7. Try to restart the router.</li> </ol>  |
| <p>No output after power on.</p>                          | <ol style="list-style-type: none"> <li>1. Make sure the address dial code setting is correct, refer to the chapter of address dial code;</li> <li>2. Make sure SOC is not 0%, otherwise charge battery.</li> </ol>  |
| <p>Unable to communicate with inverter</p>                | <ol style="list-style-type: none"> <li>1. Make sure the connection of communication cable and power cable is correct, refer to the chapter of connection of cable and power;</li> <li>2. Make sure the address dial code of the master controller connected to inverter is 1;</li> <li>3. Make sure the inverter dial code of the master controller connected to inverter is correct, refer to the chapter of inverter dial code;</li> <li>4. If you are using a pin order select box, please verify that the dialing switch is configured correctly.</li> </ol>                                  |
| <p>Unable to be charged by inverter</p>                   | <ol style="list-style-type: none"> <li>1. Make sure power cable connection is correct;</li> <li>2. Check whether inverter has faults;</li> <li>3. Check whether grid or PV is available;</li> <li>4. Make sure Time of Use of the inverter setting is correct;</li> <li>5. Make sure charging voltage and charging current setting of the inverter match the parameters of the battery;</li> <li>6. Check the battery low or high temperature protection alarm;</li> <li>7. Check the over current protection alarm;</li> <li>8. Make sure the SOC value is below 96% (default value).</li> </ol> |
| <p>Unable to discharge while SOC is not zero.</p>         | <ol style="list-style-type: none"> <li>1. Make sure the connection of cables is correct and circuit breaker is ON;</li> <li>2. Check whether inverter has faults;</li> <li>3. Make sure the inverter setting is not in back up mode;</li> <li>4. Check whether SOC is lower than the shutdown value of the inverter;</li> <li>5. Check the battery low or high temperature protection alarm;</li> <li>6. Check the over current protection alarm.</li> </ol>  |
| <p>SOC value change instantly.</p>                        | <ol style="list-style-type: none"> <li>1. It is normal that the SOC value will change when the number of parallel modules changes;</li> <li>2. It is normal that the SOC value will be calibrated when the battery has been fully charged, or deeply discharged.</li> </ol>   |
| <p>Error or Alarm shown on the screen</p>                 | <ol style="list-style-type: none"> <li>1. Check the battery. Refer to the definition of the error or warning codes. If you cannot determine the cause of the error.</li> </ol>  |

## 6.3 Status Code

The following status codes are displayed on the cloud platform.

### 6.3.1 Warning Codes

| Code | Warning type                    | Investigation & troubleshooting   |
|------|---------------------------------|---|
| W1   | Battery cell undervoltage alarm | 1. Low voltage level and needs to be charged.   |
| W2   | Charge overcurrent alarm        | 1. Restore to factory setting;<br>2. Make sure the inverter's setting of max current does not exceed the max charge current of the battery.   |
| W3   | Discharge overcurrent 1 alarm   | 1. Make sure the power of load does not exceed the power of battery.  |
| W4   | High charge temp alarm          | 1. Make sure the battery temperature shown on the inverter or the app is below 131°F (55°C), otherwise turn off the battery until the temperature is below 131°F (55°C), and then try to charge battery.    |
| W5   | High discharge temp alarm       | 1. Make sure the battery temperature shown on the inverter or the app is below 131°F (55°C), otherwise turn off the battery until the temperature is below 131°F (55°C), and then try to discharge battery. |
| W6   | Low charge temp alarm           | 1. Make sure the battery temperature shown on the inverter or the app is above 32°F (0°C), otherwise turn off the battery until the temperature is above 32°F (0°C), and then try to charge battery.        |
| W7   | Low discharge temp alarm        | 1. Make sure the battery temperature shown on the inverter or the app is above -4°F (-20°C), otherwise turn off the battery until the temperature is above -4°F (-20°C), and then try to charge battery.    |
| W8   | High ambient temp alarm         | 1. Make sure the ambient temperature of the battery is below 122°F (50°C).  |
| W9   | High voltage difference alarm   | 1. Restart the battery, and if error code W9 still remains or reappears, contact your installer.  |
| W11  | High main DC busbar temp alarm  | 1. Restart the battery, and if error code W11 still remains or reappears, contact your installer.   |
| W12  | Low insulation resistance alarm | 1. Restart the battery, and if error code W12 still remains or reappears, contact your installer.   |
| W13  | Low total voltage alarm         | 1. Low voltage level and needs to be charged  |

|      |   |  |
|------|---|--|
| W14  | Low ambient temp alarm                        | 1. Make sure the ambient temperature of the battery is above -13°F (-25°C).                        |
| W15  | High MOS temp alarm                           | 1. Reduce the ambient temperature and restart the battery.   |
| W16  | Battery cell overvoltage alarm                | 1. High voltage level and needs to be discharged.  |
| W17  | High total voltage alarm                      | 1. High voltage level and needs to be discharged.  |
| W18  | Low SOC alarm                                 | 1. Low SOC and needs to be charged.  |
| W22  | Positive connector high temp alarm            | 1. Restart the battery, and if error code W22 still remains or reappears, contact your installer.  |
| W23  | Negative connector high temp alarm            | 1. Restart the battery, and if error code W23 still remains or reappears, contact your installer.  |
| W24  | Relay high temp alarm                         | 1. Restart the battery, and if error code W24 still remains or reappears, contact your installer.  |
| W25  | Positive high temp alarm for docking terminal | 1. Restart the battery, and if error code W25 still remains or reappears, contact your installer.  |
| W26  | Negative high temp alarm for docking terminal | 1. Restart the battery, and if error code W26 still remains or reappears, contact your installer.  |
| W27  | Positive high temp alarm for discharge port   | 1. Restart the battery, and if error code W27 still remains or reappears, contact your installer.  |
| W28  | Negative high temp alarm for discharge port   | 1. Restart the battery, and if error code W28 still remains or reappears, contact your installer.  |
| W400 | PCS disconnection                             | 1. Restart the battery, and if error code W400 still remains or reappears, contact your installer. |

### 6.3.2 Error Codes

| Code | Error Type                                 | Investigation & troubleshooting  |
|------|--|--|
| F100 | The main control discharge relay is faulty | 1. Restart the battery, and if error code F100 still remains or reappears, contact your installer.   |
| F101 | The main control charge relay is faulty    | 1. Restart the battery, and if error code F101 still remains or reappears, contact your installer.   |
| F102 | Battery cell fault                         | 1. Restart the battery, and if error code F102 still remains or reappears, contact your installer.   |
| F103 | NTC fault                                  | 1. Restart the battery, and if error code F103 still remains or reappears, contact your installer.   |
| F104 | Current sensor fault                       | 1. Restart the battery, and if error code F104 still remains or reappears, contact your installer.   |
| F105 | Master and pack communication lost         | 1. Restart the battery, and if error code F105 still remains or reappears, contact your installer.   |
| F106 | Short circuit fault                        | 1. Make sure the external connection for both battery and inverters are proper;<br>2. Disconnect all external connections and restart the battery, and if error code F106 still, contact your installer. |
| F107 | Internal total voltage detection fault     | 1. Restart the battery, and if error code F107 still remains or reappears, contact your installer.   |
| F108 | Heating fault                              | 1. Restart the battery, and if error code F108 still remains or reappears, contact your installer.   |
| F109 | Battery module conflict                    | 1. Restart the battery, and if error code F109 still remains or reappears, contact your installer.   |
| F110 | Cluster address conflict                   | 1. Restart the battery, and if error code F110 still remains or reappears, contact your installer.   |
| F111 | Charge MOS fault                           | 1. Restart the battery, and if error code F111 still remains or reappears, contact your installer.   |
| F112 | Discharge MOS fault                        | 1. Restart the battery, and if error code F112 still remains or reappears, contact your installer.   |
| F113 | Addressing failure                         | 1. Restart the battery, and if error code F113 still remains or reappears, contact your installer.   |

|      |  |  |
|------|--|--|
| F114 | Precharge fault                                    | 1. Restart the battery, and if error code F114 still remains or reappears, contact your installer. |
| F115 | Cluster disconnection                              | 1. Restart the battery, and if error code F115 still remains or reappears, contact your installer. |
| F116 | Battery reverse connection fault                   | 1. Restart the battery, and if error code F116 still remains or reappears, contact your installer. |
| F117 | External total voltage detection fault             | 1. Restart the battery, and if error code F117 still remains or reappears, contact your installer. |
| F118 | Address non-1 fault                                | 1. Restart the battery, and if error code F118 still remains or reappears, contact your installer. |
| F119 | Address break-sign failure                         | 1. Restart the battery, and if error code F119 still remains or reappears, contact your installer. |
| F120 | Pack disconnect fault                              | 1. Restart the battery, and if error code F120 still remains or reappears, contact your installer. |
| F123 | Microelectronic fault                              | 1. Restart the battery, and if error code F123 still remains or reappears, contact your installer. |
| F124 | Smoke sensor fault                                 | 1. Restart the battery, and if error code F124 still remains or reappears, contact your installer. |
| F125 | The number of slave voltage strings does not match | 1. Restart the battery, and if error code F125 still remains or reappears, contact your installer. |
| F126 | Temp NTC short circuit of master relay             | 1. Restart the battery, and if error code F126 still remains or reappears, contact your installer. |
| F127 | Temp NTC open circuit of master relay              | 1. Restart the battery, and if error code F127 still remains or reappears, contact your installer. |
| F128 | Temp NTC short circuit of master DC busbar         | 1. Restart the battery, and if error code F128 still remains or reappears, contact your installer. |
| F129 | Temp NTC open circuit of master DC busbar          | 1. Restart the battery, and if error code F129 still remains or reappears, contact your installer. |
| F130 | Master and EMS communication lost                  | 1. Restart the battery, and if error code F130 still remains or reappears, contact your installer. |

|      |                                       |  |
|------|---------------------------------------|--|
| F132 | EMS SN is empty                       | 1. Restart the battery, and if error code F132 still remains or reappears, contact your installer. |
| F133 | Master SN is empty                    | 1. Restart the battery, and if error code F133 still remains or reappears, contact your installer. |
| F134 | Pack SN is empty                      | 1. Restart the battery, and if error code F134 still remains or reappears, contact your installer. |
| F136 | Relay voltage fault                   | 1. Restart the battery, and if error code F136 still remains or reappears, contact your installer. |
| F200 | Battery cell undervoltage safety lock | 1. Restart the battery, and if error code F200 still remains or reappears, contact your installer. |
| F201 | Battery cell high voltage safety lock | 1. Restart the battery, and if error code F201 still remains or reappears, contact your installer. |
| F202 | Charge high temp safety lock          | 1. Restart the battery, and if error code F202 still remains or reappears, contact your installer. |
| F203 | Charge low temp safety lock           | 1. Restart the battery, and if error code F203 still remains or reappears, contact your installer. |
| F204 | Discharge high temp safety lock       | 1. Restart the battery, and if error code F204 still remains or reappears, contact your installer. |
| F205 | Discharge low temp safety lock        | 1. Restart the battery, and if error code F205 still remains or reappears, contact your installer. |
| F206 | Charge overcurrent safety lock        | 1. Restart the battery, and if error code F206 still remains or reappears, contact your installer. |
| F207 | Discharge overcurrent safety lock     | 1. Restart the battery, and if error code F207 still remains or reappears, contact your installer. |

### 6.3.3 Protection Codes

| Code | Error Type                              | Investigation & troubleshooting  |
|------|---|--|
| P1   | Battery cell undervoltage protection    | 1. Low voltage level and needs to be charged.  |
| P2   | Overcurrent charge protection           | 1. Restore to factory setting;<br>2. Make sure the inverter's setting of max current does not exceed the max charge current of the battery.  |
| P3   | Overcurrent discharge protection        | 1. Make sure the power of load does not exceed the power of battery.   |
| P4   | High charge temp protection             | 1. Make sure the battery temperature shown on the inverter or the app is below 131°F (55°C), otherwise turn off the battery until the temperature is below 131°F (55°C), and then try to charge battery.   |
| P5   | High discharge temp protection          | 1. Make sure the battery temperature shown on the inverter or the app is below 131°F (55°C), otherwise turn off the battery till the temperature is below 131°F (55°C), and then try to discharge battery. |
| P6   | Low charge temp protection              | 1. Make sure the battery temperature shown on the inverter or the app is above 32°F (0°C), otherwise turn off the battery till the temperature is above 32°F (0°C), and then try to charge battery.        |
| P7   | Low discharge temp protection           | 1. Make sure the battery temperature shown on the inverter or the app is above -4°F (-20°C), otherwise turn off the battery till the temperature is above -4°F (-20°C), and then try to charge battery.    |
| P8   | High ambient temp protection            | 1. Make sure the ambient temperature of the battery is below 122°F (50°C).   |
| P9   | Excessive voltage difference protection | 1. Restart the battery, and if error code P9 still remains or reappears, contact your installer.   |
| P10  | Excessive temp of main control relay    | 1. Reduce the ambient temperature, and restart the battery.  |
| P11  | Overtemp protection of master DC busbar | 1. Reduce the ambient temperature, and restart the battery.  |
| P12  | Low insulation resistance protection    | 1. Restart the battery, and if error code P12 still remains or reappears, contact your installer.  |
| P13  | Low total voltage protection            | 1. Low voltage level, and needs to be charged.   |
| P14  | Low ambient temp protection             | 1. Make sure the ambient temperature of the battery is above -13°F (-25°C).  |

|     |  |   |
|-----|--|---|
| P15 | High MOS temp protection                           | 1. Reduce the ambient temperature, and restart the battery.                                       |
| P16 | Battery cell overvoltage protection                | 1. High voltage level, and needs to be discharged.  |
| P17 | High total voltage protection                      | 1. High voltage level, and needs to be discharged.  |
| P18 | Low SOC protection                                 | 1. Low voltage level, and needs to be charged.  |
| P19 | Overcurrent discharge 2 protection                 | 1. Make sure the power of load does not exceed the power of battery.                              |
| P22 | Positive connector high temp protection            | 1. Reduce the ambient temperature, and restart the battery.                                       |
| P23 | Negative connector high temp protection            | 1. Reduce the ambient temperature, and restart the battery.                                       |
| P24 | Relay high temp protection                         | 1. Reduce the ambient temperature, and restart the battery.                                       |
| P25 | Positive high temp protection for docking terminal | 1. Reduce the ambient temperature, and restart the battery.                                       |
| P26 | Negative high temp protection for docking terminal | 1. Reduce the ambient temperature, and restart the battery.                                       |
| P27 | Positive high temp protection for discharge port   | 1. Reduce the ambient temperature, and restart the battery.                                       |
| P28 | Negative high temp protection for discharge port   | 1. Reduce the ambient temperature, and restart the battery.                                       |
| P30 | Charger overvoltage protection                     | 1. Restart the battery, and if error code P30 still remains or reappears, contact your installer. |

P/N: 118.601.00.0113



Installation Video:



CEC List Checking:



UL 9540:



Product Specifications:



Renon Smart connection Guide:



---

## **Renon Power Technology Inc.**

5900 Balcones Drive Suite 100, Austin, TX 78731 USA

---

## **Renon Power Solutions Sp.z o.o.**

ul. ELBLĄSKA 1, 93-459, ŁÓDŹ, POLAND

---

## **Renon Power Technology B.V.**

Rietbaan 10, 2908 LP Capelle aan den IJssel

---

## **Renon Power 株式会社**

東京都中央区日本橋箱崎町 20-5 VORT 箱崎 5F



Whatsapp



Linkedin



Website