

PART NUMBER	ITEM NO.	DESCRIPTION	MATERIAL	QTY.
PTX-DSB	1	SCISSOR MOUNT - DECK ATTACH SLED	ALUMINUM	1
	2	BUTYL TAPE (SHOWN WITH RELEASE LINER)	BUTYL MASTIC	1
	3	DECKING FASTENER - UMBRELLA THREADS - No. 14 - TYPE 17 TIP - LENGTH 38mm - FLANGED	STAINLESS STEEL, EPDM	6

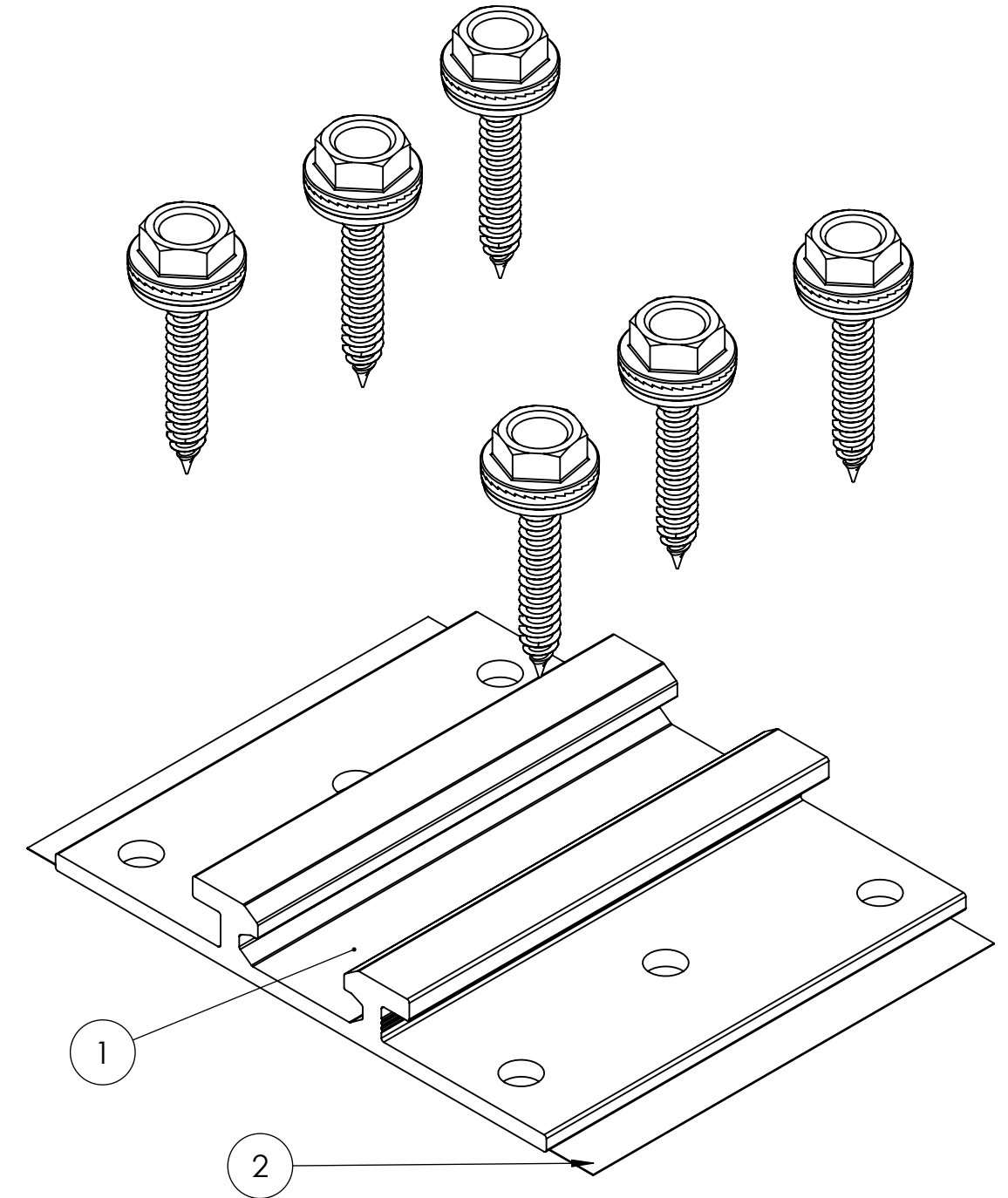
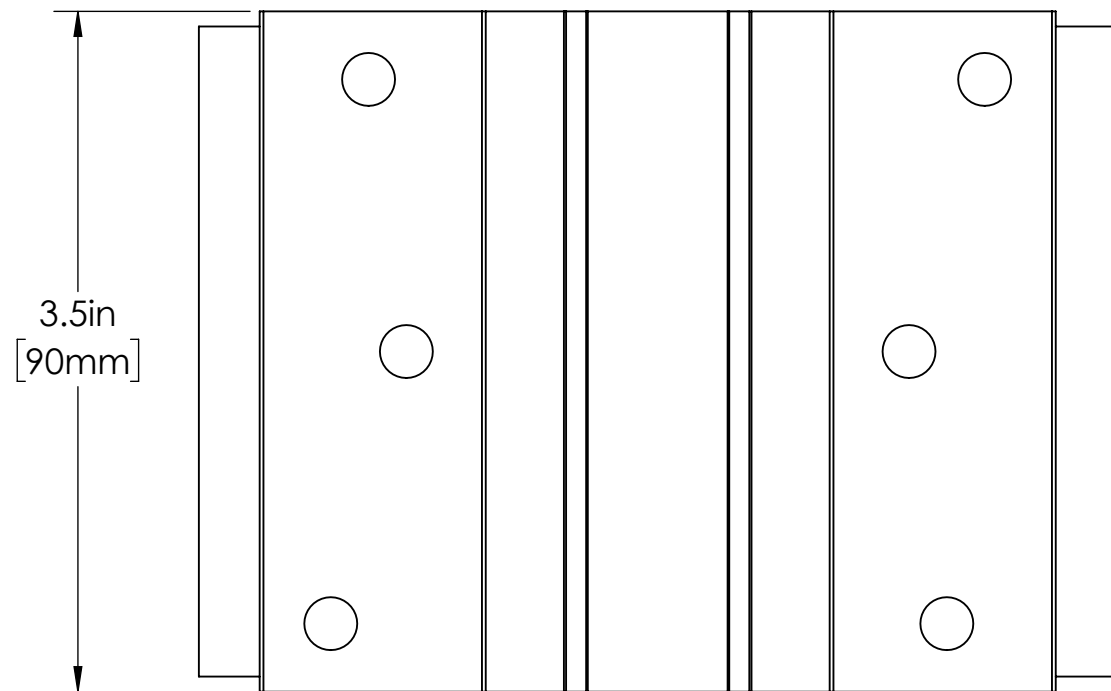
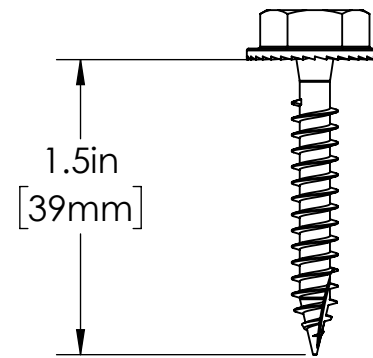
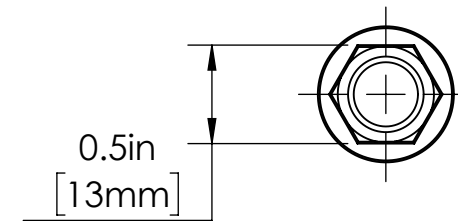
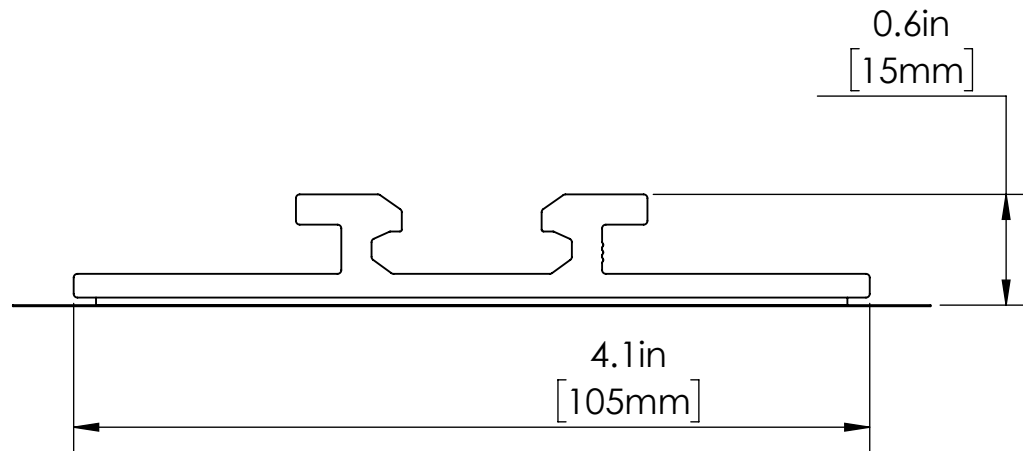

PROPRIETARY AND CONFIDENTIAL
 THE INFORMATION CONTAINED IN THIS DRAWING IS THE SOLE PROPERTY OF PEGASUS SOLAR INC. ANY REPRODUCTION IN PART OR AS A WHOLE WITHOUT THE WRITTEN PERMISSION OF PEGASUS SOLAR INC IS PROHIBITED.

COMMENTS:

UNLESS OTHERWISE SPECIFIED: DIMENSIONS ARE IN INCHES

INTERPRET DRAWING PER ASME Y14.5-2009

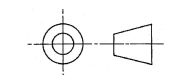

PEGASUS
 TITLE: **DECK ATTACH SLED KIT - SCISSOR MOUNT**

PART NUMBER: **PTX-DSB**

DRAWN: I. WOGAN	SIZE B	REV 3
CHECKED: K. STEPHAN	DATE: 20230404 SCALE: 1:1 SHEET 1 OF 1	