



Installation Guide

Three Phase Inverter for North America

Version 1.6

April 2025

MAN-01-01253-1.0

Table of Contents

Disclaimers	5
FCC Compliance	5
Important Notice	5
Revision History	6
HANDLING AND SAFETY INSTRUCTIONS	6
Safety Symbols Information	6
IMPORTANT SAFETY INSTRUCTIONS / CONSIGNES DE SÉCURITÉ IMPORTANTES	7
Photovoltaic Hazard Control System	13
Photovoltaic Rapid Shutdown System Requirements	14
Chapter 1: Introducing the SolarEdge Power Harvesting System	15
Power Optimizer	16
Inverter	16
Designer	16
SolarEdge ONE for C&I	17
SetApp	17
Installation Procedures	17
Installation Tools and Materials	17
Chapter 2: Install the Power Optimizers	18
Verify proper Power Optimizer connection	18
Safety	18
Package Contents	21
Installation Guidelines	21
Step 1: Mount and ground the Power Optimizers	24
Step 2: Connect a PV module to a Power Optimizer	26
Step 3: Connecting Power Optimizers in PV Strings	28
Step 4: Verify proper Power Optimizer connection	29
Restrictions on Extension Wire Usage	29
Chapter 3: Install the inverter	32
Inverter package contents	32
Identify the inverter	32
Inverter interface	32
Identify LED indications	34
Connection Unit interfaces	36
Open the conduit drill guides	37
Mount the inverter	37
Chapter 4: Connect AC and DC strings to the connection unit	40
Grid connection guidelines	40
Connect the PV strings to the connection unit of the inverter	41
Connect the AC grid to the connection unit	43
Chapter 5: Set Up Communication with the Monitoring Platform	45
Communication Options	46
External Communication Options	46
Internal Communication Options	46

Communication Connectors	46
Remove the inverter cover	47
Remove the Connection Unit cover	48
Create a Local Area Network (LAN) connection	48
Create an RS485 bus connection	51
RS485 Bus Configuration	53
Verify the connection	54
Chapter 6: Activating, Commissioning and Configuring the System	55
Step 1: Activate the Installation	55
Step 2: Commissioning and Configuring the Installation	56
Setting Country, Grid and Language	57
Power class selection	57
Pairing	59
Communication	59
Power Control	60
Verifying Proper Activation and Commissioning	60
Reporting and Monitoring Installation Data	60
SolarEdge ONE for C&I	60
Creating Logical and Physical Layout using Installation Information	61
Appendix A: Errors and troubleshooting	62
Identify errors	62
Troubleshoot communication issues	62
Troubleshoot Ethernet (LAN) communication	63
Troubleshoot communication	63
Additional troubleshooting	63
Isolation fault	63
Troubleshoot Power Optimizer issues	64
Appendix B: Add optional components	64
Add AC Surge Protection Device (SPD)	64
Add DC Surge Protection Device (SPD)	64
Appendix C: Maintenance	64
Routine maintenance of the inverter	64
Visual inspections	64
Ground connection	65
Fan maintenance	65
Wire Connections	66
General cleaning	66
Monitor the solar system performance	66
Appendix D: Interconnection standards	67
Performance categories and interconnection standards	67
Response to Abnormal Voltages and Frequencies	68
Enter Service settings	68
Grid support functions	69
Appendix E: Immunity standards	71
Appendix F: Mechanical specifications	72
Dimensions of the inverter mounting bracket	72

Appendix G: PV hazard control models 73

Appendix H: Alternative power source 73

Support contact information 74

Disclaimers

FCC Compliance

This equipment has been tested and found to comply with the limits for a Class A digital device, pursuant to part 15 of the FCC Rules.

These limits are designed to provide reasonable protection against harmful interference. This equipment generates, uses and can radiate radio frequency energy and, if not installed and used in accordance with the instructions, may cause harmful interference to radio communications. However, there is no guarantee that interference will not occur in a particular installation. If this equipment does cause harmful interference to radio or television reception, which can be determined by turning the equipment off and on, you are encouraged to try to correct the interference by one or more of the following measures:

Increase the separation between the equipment and the receiver. Reorient or relocate the receiving antenna.

- Connect the equipment into an outlet on a circuit different from that to which the receiver is connected.
- Consult the dealer or an experienced radio/TV technician for help.

Changes or modifications not expressly approved by the party responsible for compliance may void the user's authority to operate the equipment.

Important Notice

Copyright © SolarEdge Inc. All rights reserved.

No part of this document may be reproduced, stored in a retrieval system, or transmitted, in any form or by any means, electronic, mechanical, photographic, magnetic or otherwise, without the prior written permission of SolarEdge Inc.

The material furnished in this document is believed to be accurate and reliable. However, SolarEdge assumes no responsibility for the use of this material. SolarEdge reserves the right to make changes to the material at any time and without notice. You may refer to the SolarEdge website (<https://www.solaredge.com/us/>) for the most updated version.

All company and brand products and service names are trademarks or registered trademarks of their respective holders.

Patent marking notice: see <https://www.solaredge.com/us/patent> The general terms and conditions of delivery of SolarEdge shall apply.

The content of these documents is continually reviewed and amended, where necessary. However, discrepancies cannot be excluded. No guarantee is made for the completeness of these documents.

The images contained in this document are for illustrative purposes only and may vary depending on product models.

This manual describes the installation of the Three Phase Commercial Inverter. Read this manual before you attempt to install the product and follow the instructions throughout the installation process. If you are uncertain about any of the requirements, recommendations, or safety procedures described in this manual, contact SolarEdge Support immediately for advice and clarification. The information included in this manual is accurate at the time of publication. However, the product specifications are subject to change without prior notice. In addition, the illustrations in this manual are meant to help explain system configuration concepts and installation instructions. The illustrated items may differ from the actual items at the installation location.

Revision History

Version	Date	Description
1.6	April 2025	General updates.
1.5	August 2024	Updated Appendix G - added model to DC Safety switch.
1.4	July 2024	Added PV hazard control models appendix.

HANDLING AND SAFETY INSTRUCTIONS

Safety Symbols Information

The following safety symbols are used in this document. Familiarize yourself with the symbols and their meaning before installing or operating the system.



WARNING

- Denotes a hazard. It calls attention to a procedure that, if not correctly performed or adhered to, could result in **injury or loss of life**. Do not proceed beyond a warning note until the indicated conditions are fully understood and met.
- Dénote un risque: il attire l'attention sur une opération qui, si elle n'est pas faite ou suivie correctement, pourrait causer des blessures ou un danger de mort. Ne pas dépasser une telle note avant que les conditions requises soient totalement comprises et accomplies.

**CAUTION**

- Denotes a hazard. It calls attention to a procedure that, if not correctly performed or adhered to, could result in damage or destruction of the product. Do not proceed beyond a caution sign until the indicated conditions are fully understood and met.
- Dénote un risque: il attire l'attention sur une opération qui, si elle n'est pas faite ou suivi correctement, pourrait causer un dommage ou destruction de l'équipement. Ne pas dépasser une telle note avant que les conditions requises soient totalement comprises et accomplies.

**NOTE**

Denotes additional information about the current subject.

**IMPORTANT**

Denotes information about safety issues.

Disposal requirements under the Waste Electrical and Electronic Equipment (WEEE) regulations:

 Discard this product according to local regulations or send it back to SolarEdge.

IMPORTANT SAFETY INSTRUCTIONS / CONSIGNES DE SÉCURITÉ IMPORTANTES

SAVE THESE INSTRUCTIONS / CONSERVEZ CES INSTRUCTIONS

**WARNING**

- To reduce the risk of injury, read all instructions in this document.
- Pour réduire le risque de blessure, lisez toutes les instructions de ce document.

**WARNING**

- When servicing or replacing SolarEdge equipment, instructions in the SolarEdge Inverter Installation Guide must be followed to maintain the integrity of the PV hazard control system. SolarEdge Power Optimizers and/or inverters may only be replaced with SolarEdge Power Optimizers and/or inverters. Third party equipment is not compatible with SolarEdge equipment.
- Lors de l'entretien ou du remplacement de l'équipement SolarEdge, les instructions du guide d'installation de l'onduleur SolarEdge doivent être suivies pour maintenir l'intégrité du système de contrôle des risques photovoltaïques. Les optimiseurs de puissance SolarEdge et/ou les onduleurs ne peuvent être remplacés que par des optimiseurs de puissance SolarEdge et/ou des onduleurs. Les équipements tiers ne sont pas compatibles avec les équipements SolarEdge.

**WARNING**

- Using this equipment in a manner not specified by SolarEdge in this document may impair the protection provided by this equipment.
- L'utilisation de cet équipement d'une manière non spécifiée par SolarEdge dans ce document peut nuire à la protection fournie par cet équipement.

**WARNING**

- The inverter cover should be opened only after shutting off the inverter, by moving the ON/OFF/P switch to the OFF (0) position. This disables the DC voltage inside the inverter. Wait at least five minutes before opening the cover. Otherwise, there is a risk of electric shock from energy stored in the capacitors.
- Ne pas ouvrir le couvercle de l'onduleur avant d'avoir coupé l'interrupteur situé en dessous de l'onduleur. Cela supprime les tensions CC et CA de l'onduleur. Attendre cinq minutes avant d'ouvrir le couvercle. Sinon, il y a un risque de choc électrique provenant de l'énergie stockée dans le condensateur.



P = Program/Pair
1 = ON
0 = OFF

**WARNING**

- Before operating the inverter, ensure that the inverter is grounded properly. This product must be connected to a grounded, metal, permanent wiring system, or an equipment-grounding conductor must be run with the circuit conductors and connected to the equipment grounding terminal or lead on the product.
- Avant d'utiliser l'onduleur monophasé, assurez-vous que l'onduleur est correctement mis à la terre. Ce produit doit être raccordé à un système de câblage fixe, métallique, l'équipement-le conducteur de mise à la terre doit être exécuté avec les conducteurs de circuit et raccordé à l'équipement borne de mise à la terre ou de plomb sur le produit.

**WARNING**

- Opening the inverter and repairing or testing under power must be performed only by qualified service personnel familiar with this inverter.
- L'unité ne doit être ouverte que par un technicien qualifié dans le cadre de l'installation et de la maintenance.

**WARNING**

- High DC Voltage on PV strings at night when Potential Induced Degradation (PID) rectifier / Volt-Ampere Reactive (VAR) control function is active. DO NOT touch any component or perform any maintenance operation on the PV strings.
- Tension CC élevée sur les chaînes photovoltaïques la nuit lorsque le redresseur à dégradation induite potentielle (PID) / la fonction de contrôle Volt-Ampère Réactif (VAR) est active. NE touchez AUCUN composant et n'effectuez aucune opération de maintenance sur les chaînes photovoltaïques.

**WARNING**

- The Safety Unit meets all requirements for a code-compliant installation of this system. The DC Disconnect Switch disconnects both the positive and negative conductors.
- Le sectionneur externe (inclus) répond aux exigences de conformité pour l'installation de ce système. Le coupeur CC ouvre les conducteurs positifs et négatifs.

**WARNING**

- The inverter input and output circuits are isolated from the enclosure. This system does not include an isolation transformer and should be installed with an ungrounded PV array in accordance with the requirements of NEC Articles 690.35 and 690.43, ANSI/NFPA 70, 2011 (and Canadian Electrical Code, Part I, for installations in Canada). Equipment grounding is the responsibility of the installer and must be performed in accordance with all applicable Local and National Codes.
- Les circuits d'entrée et de sortie de l'onduleur sont isolés de l'enveloppe. Ce système n'inclut pas d'isolation galvanique (transformateur) et devra être installé sans mise à la terre du champ PV et en accord avec les articles 690.35 et 690.43 du National Electric Code (NEC), ANSI/NFPA 70, 2011 (et du Code Electrique Canadien, Partie 1, pour les installations faites au Canada). La mise à la terre des équipements est la responsabilité de l'installateur et doit être faite en accord avec les toutes les règles locales et nationales applicables.

**WARNING**

- SolarEdge inverters for the 480V L-L grid are rated above 750V_{DC}. As such installers are required to mark " DANGER — HIGH VOLTAGE" adjacent to each DC wiring compartment.
- Les onduleurs SolarEdge pour le réseau 480V L-L sont évalués au-dessus de 750VDC. Ainsi, les installateurs sont tenus d'indiquer « DANGER — HAUTE TENSION » à proximité de chaque compartiment de câblage DC.

**NOTE**

Utility interconnection may require approval from the authority having jurisdiction. Approval from the authority having jurisdiction is required for making adjustments to utility interactive setpoints.

**NOTE**

SolarEdge inverters always opens a disconnecting means when the inverter ceases to deliver power because of abnormal Voltage or frequency conditions or in response to a detected unintentional island.

**NOTE**

The current unbalance shall be defined as the maximum deviation of line current on any phase, from the average line current of all phases, expressed as a percentage.

The measured maximum inverter current unbalance is as specified in the below table:

Maximum inverter current unbalance

Model	% Current unbalance phase A	% Current unbalance phase B	% Current unbalance phase C
SE10K	0.6694 0	0.0057	0.0057
SE14.4K	0.6150	0.0172	0.6322
SE17.3K	0.5705	0.0353	0.6058
SE24K	0.7023	0.0834	0.6190
SE30K	0.6812	0.0583	0.6229
SE33.3K	0.6853	0.0483	0.6370
SE40K	0.6469	0.0298	0.6171



WARNING

- SolarEdge products can expose you to chemicals including antimony trioxide, which is known to the State of California to cause cancer. For more information, go to www.P65Warnings.ca.gov.
- Les produits SolarEdge peut vous exposer à des agents chimiques, y compris trioxyde d'antimoine, identifiés par l'État de Californie comme pouvant causer le cancer. Pour de plus amples informations, prière de consulter www.P65Warnings.ca.gov.



CAUTION

- This unit must be operated according to the technical specification datasheet provided with the unit.
- Cette unité doit être utilisée selon les spécifications de fonctionnement, comme décrit dans la dernière fiche technique des spécifications.



CAUTION

- HEAVY OBJECT. To avoid muscle strain or back injury, use proper lifting techniques, and if required - a lifting aid.
- Objet lourd. Pour éviter la fatigue musculaire ou des blessures au dos, utilisez des techniques de levage appropriées et, si nécessaire - un auxiliaire de levage lors du retrait.

**NOTE**

This inverter is provided with an IMI (Isolation Monitor Interrupter) for ground fault protection.

**NOTE**

The state of the ungrounded PV array may temporarily change during Isolation tests (resistor is connected between DC+ and DC- and GND points) and PID rectifier operation (small resistance is connected between DC- and GND points).

**NOTE**

The inverter is rated for:

- Overvoltage category: IV
- Pollution degree: 2

**NOTE**

This ⊕ symbol appears at grounding points on the SolarEdge equipment. This symbol is also used in this manual.

**NOTE**

All SolarEdge inverters incorporate a certified, built-in Ground Fault Current Interrupter (GFCI). The GFCI protects against electrocution in case of a malfunction in the PV array, DC cables, or DC section of the inverter. The GFCI in the SolarEdge inverter can detect current leakage on the DC side. There are two trip thresholds for the GFCI. The lower threshold is used to protect against rapid changes in current leakage - typically due to direct contact by people. The higher threshold detects slowly rising leakage currents in the grounding conductors and limits the currents to ensure fire safety. The default current value for lower speed fire safety, per unit, is 300mA. The same detection is also used for measuring the resistance of the insulation of the PV array for verifying it is higher than a pre-configured value.



NOTE

SolarEdge inverters are certified as Arc Fault Circuit Interrupters (AFCI) as per UL 1699B. For details, see [Application Note - Inverter Arc Detection in SolarEdge Systems \(North America\)](#).



NOTE

Transport the inverter upright in its original packaging or a sturdy box with handles. Store in a dry place with temperatures between -40°F and 140°F (-40°C to +60°C). For details about the inverter weight, see the datasheet included in the unit.

Photovoltaic Hazard Control System

SolarEdge commercial optimizers and inverters have been evaluated and listed to UL 3741 and may be used to form a PV hazard control system that utilizes SolarEdge PV rapid shutdown equipment to comply with NEC 690.12. Multiple modules may be connected in series to the optimizer input without exceeding the input voltage rating of the optimizer. The diagram below depicts a typical PV hazard control system using PV modules in series connected to optimizers.

Installation instructions, warnings and cautions in this installation guide must be followed to comply with Local codes. The PVHCS shall be installed by qualified people in accordance with the installation instructions and all applicable installation codes and standards.

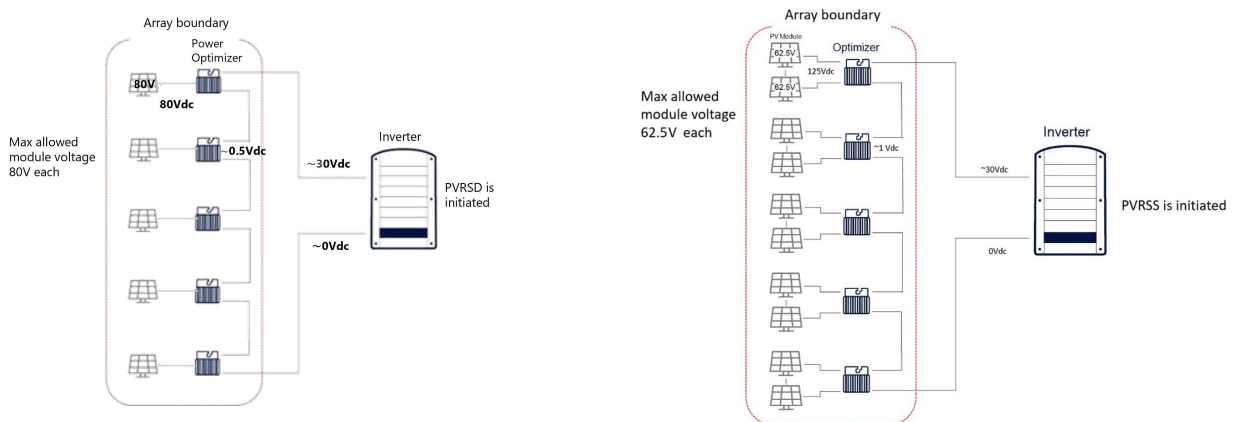

Max voltage 1:1 PV to Power Optimizer (left) and max voltage 2:1 PV to Power Optimizer (right)

Power optimizer models with input Voltage up to 125Vdc, when used with SolarEdge three phase inverters and DC safety switches listed and marked with PVRSS, may be used to form a Listed Photovoltaic Hazard Control System.

**WARNING**

- Upon servicing and/or replacing equipment, instructions in this installation guide must be followed to maintain the integrity of the PV hazard control system. SolarEdge commercial optimizers and three phase inverters should only be replaced with SolarEdge commercial optimizers and inverters. Third party equipment is not compatible.
- Lors de l'entretien et/ou du remplacement de l'équipement, les instructions de ce guide d'installation doivent être suivies pour maintenir l'intégrité du système de contrôle des risques PV. Les optimiseurs commerciaux et les onduleurs triphasés SolarEdge ne doivent être remplacés que par des optimiseurs commerciaux et des onduleurs SolarEdge. L'équipement tiers n'est pas compatible.

Photovoltaic Rapid Shutdown System Requirements

This section is applicable to all Three Phase Commercial Inverters marked with PN: xSE-SIN-USxxlxxxx.

**WARNING**

- THIS PHOTOVOLTAIC RAPID SHUTDOWN EQUIPMENT (PVRSE) INCORPORATES ONE OR MORE PIECES OF EQUIPMENT THAT EXERCISE THE RAPID SHUTDOWN CONTROL OF PV SYSTEM CONDUCTORS REQUIRED BY SECTION 690.12 OF THE NEC (NFPA 70). OTHER EQUIPMENT INSTALLED IN OR ON THIS PV SYSTEM MAY ADVERSELY AFFECT THE OPERATION OF THIS PVRSE. IT IS THE RESPONSIBILITY OF THE INSTALLER TO ENSURE THAT THE COMPLETED PV SYSTEM MEETS THE APPLICABLE RAPID SHUT DOWN FUNCTIONAL REQUIREMENTS. THIS EQUIPMENT MUST BE INSTALLED ACCORDING TO THE MANUFACTURER'S INSTALLATION INSTRUCTIONS.
 - CET ÉQUIPEMENT D'ARRÊT RAPIDE PHOTOVOLTAÏQUE (PVRSE) INCORPORE UN OU PLUSIEURS ÉLÉMENTS QUI EXERCENT LE CONTRÔLE D'ARRÊT RAPIDE DES CONDUCTEURS DU SYSTÈME PV REQUIS PAR LA SECTION 690.12 DU NEC (NFPA 70). D'AUTRES ÉQUIPEMENTS INSTALLÉS DANS OU SUR CE SYSTÈME PV PEUVENT AFFECTER NÉGATIVEMENT LE FONCTIONNEMENT DE CE PVRSS. IL EST DE LA RESPONSABILITÉ DE L'INSTALLATEUR DE S'ASSURER QUE LE SYSTÈME PV COMPLET RÉPOND AUX EXIGENCES FONCTIONNELLES D'ARRÊT RAPIDE APPLICABLES. CET ÉQUIPEMENT DOIT ÊTRE INSTALLÉ CONFORMÉMENT AUX INSTRUCTIONS D'INSTALLATION DU FABRICANT.
- SolarEdge inverters and power optimizers installed together form a photovoltaic rapid shutdown system (PVRSS). All inputs and outputs of the inverter and power optimizers comply with photovoltaic rapid shutdown requirements for controlled conductors both inside and outside the PV array boundary. To install a compliant PV rapid shutdown system, do not exceed the maximum number of Power Optimizers in series on any string.

Each Power Optimizer will output a safety voltage when rapid shutdown is initiated. Refer to the specific Power Optimizer model's datasheet for more information on maximum string length and safety output voltage. Rapid shutdown time limit is 30 Sec.

- This SolarEdge system is compatible with the Grid support interactive compatible functionality.
- All DC and AC conductors served by the power optimizers and inverters are controlled by the photovoltaic rapid shutdown system. The AC branch circuit conductors serving the inverter may remain energized until the AC service panel is de-energized. Installers must provide signage complying with Section 690.56(C) of the NEC (NFPA 70).
- Buildings with rapid shutdown PV systems, complying with NEC 690.56(C), shall have permanent labels as described in 690.56(C)(1) through (C)(2):
 - (1)(a) For PV systems that shut down the array and conductors leaving the array: The title "**SOLAR PV SYSTEM EQUIPPED WITH RAPID SHUTDOWN**" shall utilize capitalized characters with a minimum height of 3/8 in. in black on yellow background, and the remaining characters shall be capitalized with a minimum height of 3/16 in. in black on white background.

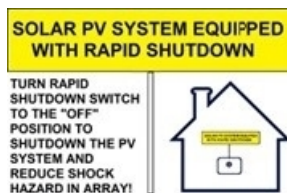

- (2) A rapid shutdown switch shall have a label located on or no more than 3ft from the switch that includes this wording. The label shall be reflective, with all letters capitalized and having a minimum height of 3/8 in., in white on a red background.

**PV SYSTEM PV WITH
RAPID SHUTDOWN**

Chapter 1: Introducing the SolarEdge Power Harvesting System

The SolarEdge power harvesting solution maximizes the power output from any type of solar photovoltaic (PV) installation while reducing the average cost per watt. The following sections describe each of the system's components.



Figure 1: SolarEdge Power Harvesting System components

Power Optimizer

The Power Optimizers are DC-DC converters connected to PV modules in order to maximize power harvesting by performing independent Maximum Power Point Tracking (MPPT) at the module level. Each Power Optimizer also transmits module performance data over the DC power line to the inverter.



NOTE

The safety output voltage level for each Power Optimizer varies depending on the model and can be found in the relevant datasheet.

Inverter

An external inverter efficiently converts DC power from the modules into AC power that can be fed into the main AC service of the site and from there to the grid. The inverter also receives the monitoring data from each Power Optimizer and transmits it to a central server (The monitoring platform requires Internet connection). The Connection Unit has a manually operated switch for disconnecting the DC power of a SolarEdge system. The Connection Unit is located below the inverter and is connected to the inverter with AC and DC wires.

Designer

SolarEdge Designer is a powerful tool and a user-friendly web application that simplifies solar energy system design. It offers an intuitive interface and advanced optimization features to help professionals create efficient PV designs. With accurate simulation algorithms and integration with SolarEdge products, it maximizes system performance. The application also enables financial analysis and supports collaboration.

SolarEdge ONE for C&I

ONE for C&I enables monitoring the technical and financial performance of one or more SolarEdge sites. It provides past and online information on the system performance, both at the system and PV module levels.

SetApp

SolarEdge SetApp is a mobile application designed to simplify the process of commissioning and configuring SolarEdge inverters and power optimizers by providing an intuitive and efficient interface for installers.

With SetApp, installers can easily access and configure SolarEdge inverters and power optimizers through their smartphone or tablet. The user-friendly app guides installers step-by-step through the entire commissioning process, ensuring that each component is properly connected and configured for optimal performance. This eliminates the need for complex manual setup procedures and significantly reduces the time and effort required for system installation.

Installation Procedures

The following procedures are required for installing and setting up a new SolarEdge site. Some of these procedures also apply to modification of an existing site:

- Mount the inverter, see Chapter 3.
- Connect the inverter to the Monitoring platform, see Chapter 5.
- Commission the inverter, see Chapter 6.
- Record the Power Optimizer serial number, see Chapter 6 Reporting and Monitoring Installation Data.

Installation Tools and Materials

Standard tools can be used during the installation of the SolarEdge system. The following is a recommendation of the equipment needed for installation:

- 4 mm Allen torque screwdriver for the inverter enclosure screws
- Standard torque flat-head screwdrivers set
- Non-contact voltage detector
- Cordless drill with torque clutch or screwdriver and bits suitable for the surface on which the inverter and optimizers will be installed and for opening the Connection Unit drill guides.



CAUTION

- Use of an impact driver is not allowed.
- L'utilisation d'une visseuse à percussion n'est pas autorisée.

- Mounting hardware (stainless bolts, nuts, and washers) for attaching:
 - Mounting brackets to the mounting surface
 - Power optimizer to the racking (not required in smart modules)
- Up to four "3/4" or 1" standard nipple offsets to connect conduits between the inverter and a 6" depth gutter

**NOTE**

You can use an 8" depth gutter without the nipple offsets.

- Tools
 - Wire cutters
 - Wire strippers
 - Voltmeter
 - Mobile device with the latest SetApp version
- For installing the communication options, you may also need the following:
 - For Ethernet
 - CAT6 twisted pair Ethernet cable with RJ45 connector
 - If using a CAT6 cable spool: RJ45 plug and RJ45 crimper
 - For RS485 / CAN bus:
 - Four or six-wire shielded twisted pair cable
 - Watchmaker precision screwdriver set

Chapter 2: Install the Power Optimizers

Verify proper Power Optimizer connection

Safety

The following notes and warnings apply when installing the SolarEdge Power Optimizers. Some of the following may not be applicable to smart modules:

**WARNING**

- The metallic enclosure of the Power Optimizer must be grounded in accordance with the product's listing and local and national codes.
- L'enceinte métallique de l'optimiseur de puissance doit être mise à la terre en accord avec les réglementations locales et nationales.

**WARNING**

- When modifying an existing installation, turn OFF the inverter P/1/0 switch, the DC Disconnect Switch and the AC circuit breaker on the main AC distribution panel.
- Avant de faire ces étapes, éteignez l'onduleur monophasé en mettant sur OFF l'interrupteur P/1/0 situé au bas de l'onduleur.

**CAUTION**

- Power Optimizers are IP68/NEMA6P rated. Choose a mounting location where optimizers will not be submerged in water.
- Les optimiseurs de puissances sont compatibles à la norme IP68/NEMA6P. Choisissez le lieu de montage tel que l'optimiseur ne puisse pas être submergé par l'eau.

**CAUTION**

- This unit must be operated according to the operating specifications provided with the unit.
- Cette unité doit être opérée suivant les instructions trouvées dans le manuel fourni avec le produit.

**CAUTION**

- Cutting the Power Optimizer input or output cable connector is prohibited and will void the warranty.
- Sectionner les câbles d'entrées ou de sortie de l'optimiseur est interdit et annule sa garantie.

**CAUTION**

- All PV modules must be connected to a Power Optimizer.
- Tous les modules doivent être connectés à un optimiseur de puissance.

**CAUTION**

- If you intend to mount the Power Optimizers directly to the module or module frame, first consult the module manufacturer for guidance regarding the mounting location and the impact, if any, on module warranty. Drilling holes in the module frame should be done according to the module manufacturer instructions.
- Pour installation à même le module ou la monture du module, consultez d'abord le fabricant du module sur la position et son impact sur la garantie du module. Le perçage de trous dans le cadre du module devra se faire suivant les instructions du fabricant.

**IMPORTANT**

Modules with SolarEdge Power Optimizers are safe. They carry only a low safety voltage before the inverter is turned ON. As long as the Power Optimizers are not connected to the inverter or the inverter is turned OFF, each Power Optimizer will output a safe voltage. For information regarding safe voltages, see the relevant datasheet.

**CAUTION**

Installing a SolarEdge system without ensuring compatibility of the module connectors with the Power Optimizer connectors may be unsafe and could cause functionality problems such as ground faults, resulting in inverter shut down. To ensure mechanical compatibility of the SolarEdge PowerOptimizers' connectors with the PV modules' connectors to which they are connected:

- Use identical connectors from the same manufacturer and of the same type on both the Power Optimizers and on the modules; or
- Verify that the connectors are compatible in the following way:
 - The module connector manufacturer should explicitly verify compatibility with the SolarEdge Power Optimizer connector
 - A third-party test report by one of the listed external labs (TUV, VDE, Bureau Veritas UL, CSA, InterTek) should be obtained, verifying the compatibility of the connectors

Les connecteurs du module doivent être mécaniquement compatibles avec les optimiseurs de puissance. Sinon, le système SolarEdge installé peut être dangereux ou causer des problèmes fonctionnels, tels que les défauts de terre, qui peuvent provoquer un arrêt de l'onduleur. Afin d'assurer la compatibilité mécanique entre les optimiseurs de puissance SolarEdge et les modules auxquels ils sont connectés:

- Utiliser des connecteurs identiques du même fabricant et du même type aussi bien pour les optimiseurs de puissance que pour les modules.
- Vérifiez que les connecteurs sont compatibles de la manière suivante:
- Le fabricant du connecteur doit explicitement vérifier la compatibilité avec le connecteur SolarEdge.
- Un rapport de test de tierce partie doit être effectué par l'un des laboratoires externes indiqués ci-dessous:(TUV, VDE, Bureau Veritas UL, CSA,Intertek), qui vérifiera la comp.

Package Contents

- Power Optimizers
- Stainless steel grounding lock washers

Installation Guidelines

For the minimum and maximum number of Power Optimizers in a PV string (PV string length), see the Power Optimizer datasheets. To verify the PV string length, use the [SolarEdge Designer](#) on the SolarEdge website.

Maximum length of string wires

Inverter type	Inverter model number	Maximum string length
Three Phase Commercial Inverters	SE9KUS, SE20KUS SE10KUS, SE30KUS	300m/1000ft
	SE14.4KUS, SE17.3KUS, SE33.3KUS, SE40KUS	700m/2300ft

For details, see [Using Extension Wires and Adapter Wires with Power Optimizers — Application Note](#).

Do not use extension cables between a module and a Power Optimizer, between two modules connected to the same Power Optimizer, or between two Power Optimizers other than the following cases:

- Extension cables of up to 6 ft / 1.8 m are allowed for all Power Optimizers (3 ft / 0.9 m for DC+, and 3 ft / 0.9 m for DC -)
- SolarEdge Sense Connect technology monitors the S-Series and C-Series Power Optimizer cable connectors and the direct connection created between them and another connector
- P-Series Power Optimizers with the 4-type suffix in their part number (Pxxx- 4xxxxxx) and the Mxxxx-Series - extension cables of up to 52 ft / 16 m can be installed per Power Optimizer (26 ft / 8 m for DC+, and 26 ft / 8 m for DC-)

Between two PV modules connected in series to a Power Optimizer

When connecting two PV modules in series to supported Power Optimizers – an extension cable may be installed between the two modules, if the following conditions are met:

- The total round-trip cable length between the (+) and the (-) input terminals of the power optimizer (including the extension cable between the modules and the module output cables) does not exceed 16m/52.5ft
- Supported Commercial Power Optimizers with the following part numbers are used:
 - Pxxx-4xxxxxx (P Series with 4-type in part number suffix)
 - Sxxx-1xxxxxx (S Series with 1-type in part number suffix)
- The connectors on each end of the extension cable must be identical to PV module's output connectors.



NOTE

The extension cable between two modules is considered as auxiliary equipment and is not covered by the SolarEdge warranty.

**NOTE**

- When using a serial input optimizer for up to two modules connected in series, and PV modules installed in landscape orientation, it is recommended to use PV modules with long output cables to avoid the use of an extension (jumper cable) between two modules.
- "Modules with long output cables" refers to modules with longer cables intended for landscape installation. The output cables length is usually specified in the Mechanical Characteristics section of the PV Module Datasheet. For planning considerations when connecting multiple PV modules to an Power Optimizer, see: [Application Note: Connecting SolarEdge Power Optimizers to Multiple PV Modules](#).

Between two Power Optimizers or between a Power Optimizer and the inverter:

- Extension cables can be installed between Power Optimizers only from row to row, around obstacles or pathways within a row and from the end of the PV string to the inverter. For more information on how to use extension and adapter cables with power optimizers, see [Using Extension Wires and Adapter Wires with Power Optimizers — Application Note](#).
- Frame-mounted Power Optimizers are mounted directly on the module frame, regardless of racking system (rail-less or with rails). For installation of frame-mounted Power Optimizers, see [Application Note - Installing Frame-Mounted Power Optimizers](#).
- The Power Optimizer can be placed in any orientation
- Position the Power Optimizer close enough to its module so that their cables can be connected.
- Make sure to use Power Optimizers that have the required output and input conductor length.
- Completely shaded modules may cause their Power Optimizers to temporarily shut down. This will not affect the performance of the other Power Optimizers in the PV string, as long as the minimum number of unshaded Power Optimizers connected in a PV string of modules is met. If under typical conditions fewer than the minimum Power Optimizers are connected to unshaded modules, add more Power Optimizers to the PV string.
- To allow for heat dissipation, maintain the following clearance: For All Power Optimizers, except for the P860, P960 and M1600.

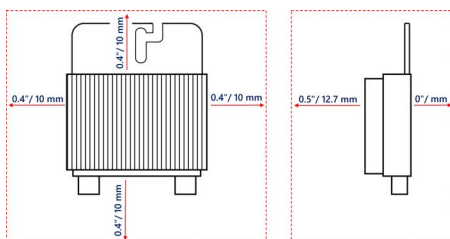

Figure 2: Clearance for heat dissipation around the Power Optimizer

- Equipment grounding tightening torques: 4-6 AWG: 45 lbf-in, 8 AWG: 40 lbf-in, 10-14 AWG: 35 lbf-in.
- When installing PV modules in a confined space such as Building-integrated photovoltaic (BIPV) modules, ventilation measures may be required to ensure that the Power Optimizers are not exceeding the maximum temperatures stated in their specifications.

Step 1: Mount and ground the Power Optimizers

To mount each Power Optimizer: ¹

1. Determine the Power Optimizer mounting location and use the Power Optimizer mounting brackets to attach the Power Optimizer to the support structure. [See Figure 4. \[25\]](#) It is recommended to mount the Power Optimizer in a location protected from direct sunlight.
2. If required, mark the mounting hole locations and drill holes.



CAUTION

- Drilling vibrations may damage the Power Optimizer and will void the warranty. Use a torque wrench or an electric drill with adjustable clutch that meets the mounting torque requirements. Do not use impact drivers for mounting the Power Optimizer. Do not drill through the Power Optimizer or through the mounting holes.
- Les vibrations résultant du perçage peuvent endommager l'optimiseur de puissance et annulera la garantie. Utilisez une clé dynamométrique ou une perceuse électrique avec embrayage adaptable compatible avec les moments indiqués. Ne pas utiliser des tournevis à percussion pour fixer l'optimiseur. Ne pas percer à travers l'optimiseur de puissance ou ses trous de fixation.

3. Attach each Power Optimizer to the rack using M6 (1/4") or M8 stainless steel bolts, nuts and washers or other mounting hardware. Apply torque of 6.5-7 lbf•ft/9-10N•m.
4. Use the following methods to ground the Power Optimizer:



WARNING

- The metallic enclosure of the Power Optimizer must be grounded in accordance with the requirements of the local and national codes.
- L'enceinte métallique de l'optimiseur de puissance doit être mise à la terre en accord avec les réglementations locales et nationales.

For mounting on a grounded metal rail:

Use SolarEdge approved 5/16" stainless steel grounding star washer between the railing and the flat side of the mounting bracket.

The star washer (used for grounding) should break through the anodize coating of the railing to ensure low resistive connection. Apply a torque of 9.5N•m / 7lbf•ft.

¹Not applicable to Smart Modules.

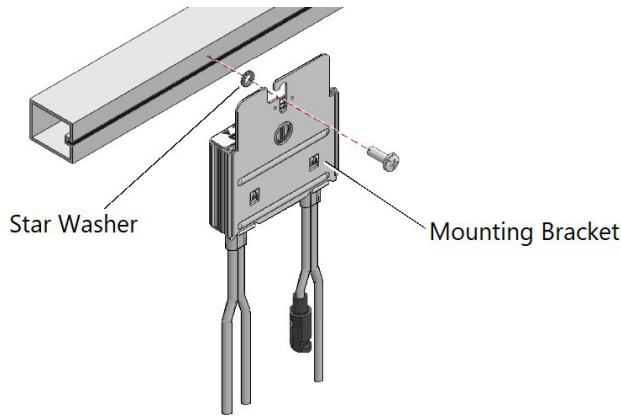

Figure 4: Power Optimizer installation and grounding using a star washer



NOTE

Star washers for the S-series and C-series Power Optimizers are not included and can be purchased in bulk (SolarEdge part number OPT-Washer-100 or OPT-Washer-500).

For mounting on rails with sliding nut fasteners:

Use mounting required hardware to apply a torque of 9.5N•m / 7lbf•ft.

For details, see [Grounding SolarEdge Power Optimizers](#).

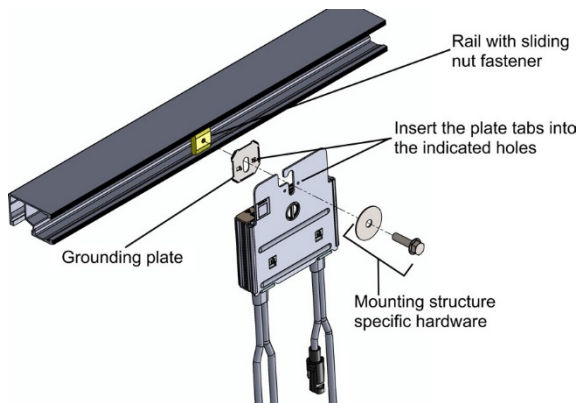

Figure 5: Power Optimizer installation and grounding using a grounding plate



NOTE

If the star washer cannot be used, use the SolarEdge grounding plate (purchased separately - Part Number: SE-GNDPLATE-100) between the railing and the flat side of the mounting bracket.

For mounting on un-grounded structures(such as a wooden structure):

- If the star washer or the plate cannot be used, use the SolarEdge grounding lug (purchased separately) with an equipment-grounding conductor according to the supplied instructions.
- The grounding terminal accepts wire sizes of 6-14 AWG and must be sized for equipment grounding per NEC 250.122 requirements.
- Tighten the screws connecting the Power Optimizer to the frame and the grounding terminal screw. Apply a torque of 9.5N•m/7lbf•ft.

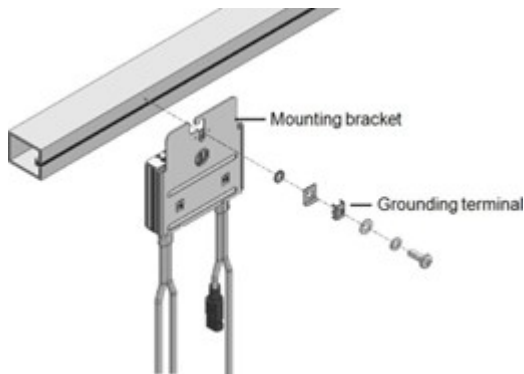

Figure 6: Power optimizer grounding terminal

5. Verify that each Power Optimizer is securely attached to the module support structure.
6. Record Power Optimizer serial numbers and locations, according to [Report and monitor installation data](#).



NOTE

When installing the Power Optimizers before the PV Modules, protect the connectors from rain and dust by using the provided seals. A seal kit can also be purchased separately: (Part ID: OPT-SEAL-100).

Step 2: Connect a PV module to a Power Optimizer



NOTE

Improper wiring may cause electrical faults in a PV system. To avoid electrical faults, verify proper locking of connectors and avoid cable tension and friction. Proper planning, materials and installation reduce the risk of electric arcs, short-circuits and ground faults in the PV system.



NOTE

Images are for illustration purposes only. Refer to the label on the product to identify the plus and minus input and output connectors.

To connect a 2-to-1 PV module to each Power Optimizer:

1. Connect the plus (+) output connector of one module (A) to the plus (+) input connector of the Power Optimizer.
2. Connect the minus (-) output connector of the other module (B) to the minus (-) input connector of the Power Optimizer.
3. Connect the plus (+) output connector of module (A) to the minus (-) output connector of module (B).



Figure 7a: S-Series (left) and P-Series (right) Power Optimizer connectors

To connect a 1-to-1 PV Module to a Power Optimizer:

1. Connect the plus (+) output connector of the module to the plus (+) input connector of the Power Optimizer.
2. Connect the minus (-) output connector of the module to the minus (-) input connector of the Power Optimizer.

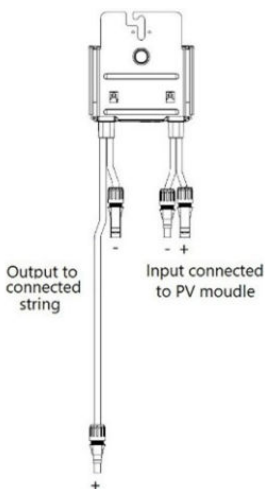

Figure 7b: C-Series 1:1 Power Optimizer connectors

Step 3: Connecting Power Optimizers in PV Strings

You can construct parallel PV strings of unequal length, that is, the number of Power Optimizers in each PV string does not have to be the same. The minimum and maximum PV string lengths are specified in the Power Optimizer datasheets. Refer to the SolarEdge Designer for PV string length verification.



IMPORTANT

- For a compliant PV Rapid Shutdown (PVRSD) installation, use no more than the maximum power optimizers per string, as specified in the datasheet.
- Enabling PVRSS from the inverter menu is required only if the installed Power Optimizers were manufactured before 2015; otherwise, it is enabled by default.



NOTE

The DC bus of each unit is separate and not shared for all units. Therefore, in addition to following the inverter design rules, each unit should follow the unit design rules as detailed in the Technical Specifications.

To connect Power Optimizers to PV strings:

1. Connect the Minus (-) output connector of the PV string's first Power Optimizer to the Plus (+) output connector of the PV string's second Power Optimizer.
2. To minimize electromagnetic interference (EMI), make sure to minimize the distance between the positive and negative DC cables. For detailed instructions, see: <https://knowledge-center.solaredge.com/sites/kc/files/se-emi-performance-application-note.pdf>



3. Connect the rest of the Power Optimizers in the PV string in the same manner.

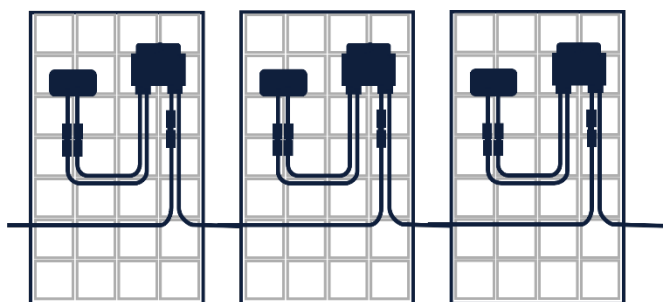

Figure 8: Power Optimizers connected in series

4. If you intend to monitor the installation, using the SolarEdge Monitoring platform, record the physical location of each Power Optimizer, as described in [Creating Logical and Physical Layout using Installation Information \[61\]](#)

Step 4: Verify proper Power Optimizer connection

When a module is connected to a Power Optimizer, the Power Optimizer outputs a safe voltage. Therefore, the total PV string voltage should equal the number of Power Optimizers connected in series in the PV string times the rated Safety Output Voltage of the Power Optimizer.

For example:

- If 10 * S1201 Power Optimizers are connected in a PV string, then 10V should be produced.
- 14 * C651 Power Optimizers are connected in a PV string, then 7V should be produced.

Make sure the PV modules are exposed to sunlight during this process. The Power Optimizer will only turn ON if the PV module provides at least 2W.

In SolarEdge systems, due to the introduction of Power Optimizers between the PV modules and the inverter, the short circuit current I_{SC} and the open circuit voltage V_{OC} hold different meanings from those in traditional systems.

For more information about the SolarEdge system's PV string Voltage and current, refer to the [V_{OC} and I_{SC} in SolarEdge Systems - Technical Note](#).

To verify proper Power Optimizer connection:

Measure the voltage of each PV string individually before connecting it to the other PV strings or to the inverter. Verify correct polarity by measuring the PV string polarity with a voltmeter. Use a voltmeter with at least 0.1V measurement accuracy.



NOTE

Since the inverter is not yet operating, you may measure the PV string Voltage and verify correct polarity on the DC wires.

For troubleshooting Power Optimizer operation problems, refer to [Power Optimizer Troubleshooting](#)

Proper Power Optimizer connection can also be verified in the Designer application. For more information, see <https://www.solaredge.com/products/installer-tools/designer#/>.

Restrictions on Extension Wire Usage

Do not use extension wires between a module and a Power Optimizer, between two modules connected to the same Power Optimizer, or between two Power Optimizers other than in the following use cases:

- Between a module and a Power Optimizer: Extension cables of up to 6 ft / 1.8 m are allowed for all Power Optimizers (3 ft / 0.9 m for DC+, and 3 ft / 0.9 m for DC-).

The SolarEdge Sense Connect technology monitors the S-Series and C-Series Power Optimizer cable connectors and the direct connection created between them and another connector. For P-Series Power Optimizers with the 4-type suffix in their part number (Pxxx-4xxxxxx) and the Mxxxx-Series, extension cables of up to 52 ft / 16 m can be installed per Power Optimizer (26 ft / 8 m for DC+, and 26 ft / 8 m for DC-).

- Between two PV modules connected in series to a Power Optimizer: When connecting two PV modules in series to supported Power Optimizers, an extension cable may be installed between the two modules if the total round-trip cable length between the (+) and the (-) input terminals of the power optimizer does not exceed 16m/52.5ft and the supported Commercial Power Optimizers with specific part numbers are used. The connectors on each end of the extension cable must be identical to the PV module’s output connectors.

Use case	Extension wire length
Between a module and a Power Optimizer	<ul style="list-style-type: none"> • Up to 6 ft / 1.8 m for all Power Optimizers (3 ft / 0.9 m for DC+, and 3 ft / 0.9 m for DC-). • SolarEdge Sense Connect technology monitors the S-series and C-series Power Optimizer cable connectors and the direct connection created between them and another connector. • For P-series Power Optimizers with the 4-type suffix in their part number (Pxxx-4xxxxxx) and the Mxxxx-Series, extension wires of up to 52 ft / 16 m can be installed per Power Optimizer (26 ft / 8 m for DC+, and 26 ft / 8 m for DC-).
Between two PV modules connected in series to a Power Optimizer	<ul style="list-style-type: none"> • You can install an extension wire between the two modules if the total round-trip cable length between the (+) and the (-) input terminals of the power optimizer does not exceed 16m/52.5ft and the supported Commercial Power Optimizers with specific part numbers are used. • The connectors on each end of the extension wire must be identical to the PV module’s output connectors.

Use case	Extension wire length
<p>Between two Power Optimizers or between a Power Optimizer and the inverter:</p>	<ul style="list-style-type: none"> You can install extension wires between Power Optimizers only from row to row, around obstacles or pathways within a row and from the end of the PV string to the inverter. For details on how to use extension and adapter cables with power optimizers, see Using Extension Wires and Adapter Wires with Power Optimizers. Frame-mounted Power Optimizers are mounted directly on the module frame, regardless of racking system (rail-less or with rails). For installation of frame-mounted Power Optimizers, see - Installing Frame-Mounted Power Optimizers. You can place the Power Optimizer in any orientation. If connecting more modules than Power Optimizer inputs in parallel, use a branch cable. Some commercial Power Optimizer models have a dual input. Position the Power Optimizer close enough to its module so that their cables can be connected. Make sure to use Power Optimizers that have the required output and input conductor length.

**NOTE**

The extension wire between two models is considered auxiliary equipment and is not covered by SolarEdge warranty.

**NOTE**

- When using a serial input optimizer for up to two modules connected in series, and PV modules installed in landscape orientation, it is recommended to use PV modules with long output cables to avoid the use of an extension (jumper cable) between two modules.
- "Modules with long output cables" refers to modules with longer cables intended for landscape installation. The output cables length is usually specified in the Mechanical Characteristics section of the PV Module Datasheet.
- For planning considerations when connecting multiple PV modules to a Power Optimizer, see [Connecting SolarEdge Power Optimizers to Multiple PV Modules](#).
- Completely shaded modules can cause their Power Optimizers to temporarily shut down. This does not affect the performance of the other Power Optimizers in the PV string, if the minimum number of unshaded Power Optimizers connected in a PV string of modules is met. If, under typical conditions, fewer than the minimum Power Optimizers are connected to unshaded modules, add more Power Optimizers to the PV string.

Chapter 3: Install the inverter

You can install the inverter either before or after the PV modules and Power Optimizers have been installed.

Inverter package contents

- One inverter with a Connection Unit
- Mounting bracket kit
- Quick Installation Guide
- Warranty card
- Safety instructions page
- Technical specifications page

Identify the inverter

Refer to the sticker on the inverter that specifies its Serial Number and its Electrical Ratings. Provide the serial number when contacting SolarEdge support. The serial number is also required when opening a new site in the monitoring platform.

Inverter interface



NOTE

The Connection Unit is applicable based on the inverter model and country of installation.

Figure 9: shows an inverter with a Connection Unit located at the bottom of the inverter

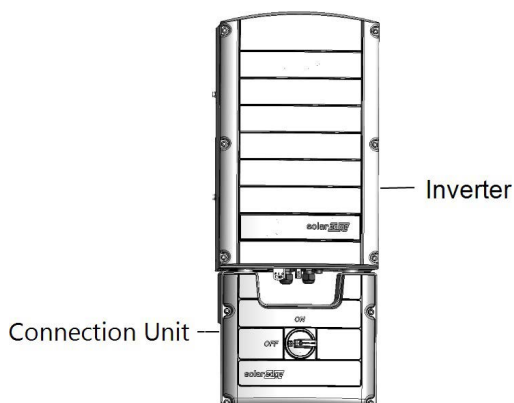

Figure 10: Front view of the inverter

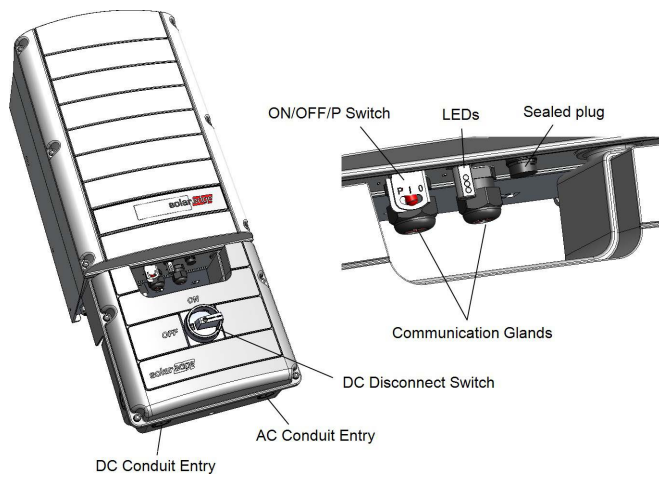

Figure 11: View of the inverter connectors and components located on the bottom of the inverter.

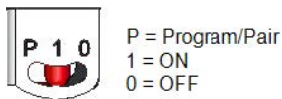



Figure 12: P/1/0 switch

Inverter components

Component	Function
AC conduit entry	Connection entry points of the Connection Unit
DC conduit entry	Connection entry points of the Connection Unit
Communication glands (2)	Glands for connecting inverter communication options Each gland has three openings For details, see Set up communication with the Monitoring platform on page 45.
P/1/0 switch	Pairs and turns inverters ON and OFF
1 position	Turns ON the inverter unit
0 position	Turns OFF the inverter unit and the PV system
	<div style="border: 1px solid #ccc; padding: 10px; background-color: #f9f9f9;"> <p> NOTE When this switch, the internal control circuitry of the inverter remains ON.</p> </div>
P position	Pairs the mobile device to the inverter

1/0/P switch functions

Position Duration	Function	Description
Move the switch to P and hold for two seconds	<ul style="list-style-type: none"> • LEDs displays production or error information for five seconds • Activates the Wi-Fi access point for connecting to SetApp 	<ul style="list-style-type: none"> • While the switch is in the the P position, all LEDs are ON • When you release the switch, all LEDs are OFF for 0.5 seconds, and then display the production or error indication
Move the switch to P and hold for five or more seconds	Starts pairing	Pairing is indicated by all three LEDs blinking simultaneously

Identify LED indications

LEDs: three LEDs indicate, by color and state (on/ off/, blinking/flickering,/alternating), different system information, such as errors or performance indications. For more information, see: <https://www.solaredge.com/leds>.

The main LED indications are:

- Blue ON - the inverter is communicating with the Monitoring platform
- Green ON - the system is producing
- Green blinking AC is connected but the system is not producing
- Red ON -system error

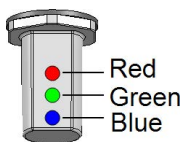

Figure 13: LED indicators

The following table describes system performance information by LED color and the P/1/0 switch position.

LED indications

Indication	P/1/0 switch position	LED color			Comment
		Red	Green	Blue	
Power Optimizers are not paired	ON (1)	OFF	Blinking	S_OK: ON No S_OK: OFF	S_OK: ON communication with the monitoring platform is established.
Pairing		Blinking	Blinking	Blinking	
Wake-up/ Grid Monitoring		OFF	Blinking	Blinking	
System Producing		OFF	ON	S_OK: ON No S_OK: OFF	For detailed percentage of production, refer to the following table.
Night mode (no production)		OFF	Flickering	S_OK: ON No S_OK: OFF	
Inverter is OFF (Safe DC)	OFF (0)	OFF	Blinking	S_OK: ON No S_OK: OFF	
Inverter is OFF (DC not safe)		Blinking	Blinking	S_OK: ON No S_OK: OFF	
Inverter configuration or reboot	On (1) / P	ON	ON	ON	
Inverter firmware upgrade	ON (1) / P	Alternating	Alternating	Alternating	The upgrade process can take up to 5 minutes
Error	Any	ON	ON/ OFF/ Blinking/ Flickering	ON/ OFF / Blinking	See Errors and troubleshooting

The following table describes production percentage of AC information by LED color and P/1/0 switch position.

Production percentage

Indication	1/0/P switch position	LED color			Comment
		Red	Green	Blue	
Percentage of AC Production: 0 %	ON (1)	OFF	OFF	OFF	This indicates power production as percentage of rated peak AC output power
Percentage of AC Production: 0 - 33 %		OFF	ON	OFF	
Percentage of AC Production: 33 - 66 %		OFF	OFF	ON	
Percentage of AC Production: 66 - 100 %		OFF	ON	ON	

Connection Unit interfaces

The Connection Unit includes:

- ON/OFF switch: connect or disconnect the DC power from the PV strings
- AC conduit entries: connect of AC cable to the grid
- DC conduit entries: connect the DC wires from the PV strings



NOTE

- Open the required AC and DC conduit drill guides according to the conduits used in the installation.
- Do not interfere with any of the internal components
- We recommend you use a Unibit drill with 3/4-1" to create the conduit holes

When the safety switch of the Connection Unit is turned OFF, such as during maintenance, it can be locked to prevent safety hazards.

To lock the Connection Unit switch:

1. Move the switch to the Lock position.
2. Insert the lock through the knob opening and secure it.



Figure 14 : Connection Unit switch

Open the conduit drill guides

Open the drill guides before mounting the inverter.

To open the conduit drill guides:

1. Move the DC Disconnect Switch and the inverter ON/OFF switch to OFF.
2. Loosen the screws on the front cover of the Connection Unit, as shown below:

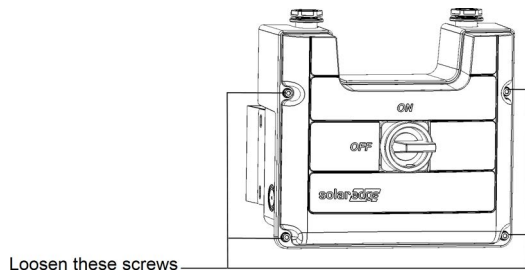

Figure 15: Connection Unit cover

3. Remove the Connection Unit cover.
4. Open the required conduit drill guides according to the conduits used in the installation: The drill guides are located at the bottom, right, left and back sides of the enclosure, each with two sizes: $\frac{3}{4}$ " and 1". Open the required drill guides, taking care not to interfere with any of the internal components. It is recommended to use a Unibit drill.

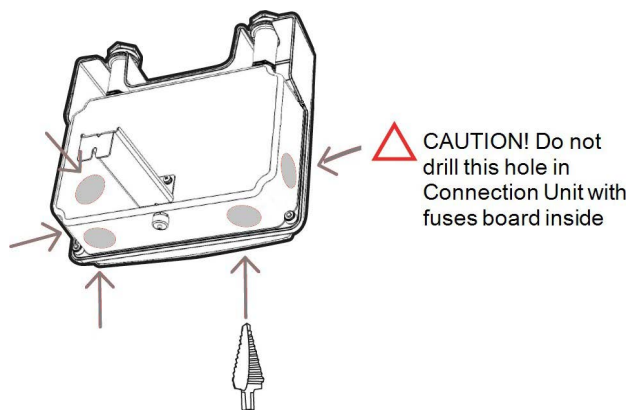

Figure 16: Rear view of Connection Unit - drilling guides



NOTE

Make sure to close the conduit openings with the appropriate seals.

Mount the inverter

The inverter is supplied with a mounting bracket kit as shown in Figure 14.

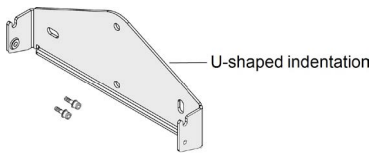

Figure 16: Mounting bracket kit



NOTE

Make sure the mounting surface or structure can support the weight of the inverter.



CAUTION

- SolarEdge inverters and Power Optimizers can be installed at a minimum distance of 50m/164ft from the shoreline of an ocean or other saline environment, if there are no direct saltwater splashes on the inverter or Power Optimizer. For SolarEdge inverters installed at 200m/655 ft or closer to the shoreline, special brackets must be purchased separately from SolarEdge and SS304 stainless screws are required. For details, please contact your local sales representative.
- Les onduleurs SolarEdge peuvent être installés à une distance minimum de 50m de la ligne d'eau de l'océan ou autre environnement salin, tant qu'il n'y a pas d'éclaboussements d'eau salée directs sur l'onduleur. Pour les onduleurs SolarEdge installés à une distance de 200 m ou moins du rivage, des supports spéciaux achetés séparément auprès de SolarEdge et des vis inox SS304 sont nécessaires. Pour les détails, veuillez contacter le commercial de votre région.

To mount the inverter:

1. Determine the inverter mounting location, on a wall, rails, stud framing or pole. It is recommended to mount the inverter in a location protected from direct sunlight.
2. To allow proper heat dissipation, maintain the following minimum clearance areas between the inverter and other objects described in [Clearance Guidelines for Mounting Three Phase Inverters - Application Note](#).
3. Verify that the fan, located at the bottom of the inverter, is not blocked and that air can flow freely.



Figure 17: Inverter fan airflow

**CAUTION**

Do not block airflow from the inverter.

To mount the inverter:

1. Position the mounting bracket against the wall/pole and mark the drilling hole locations. For details see Appendix F: Mechanical Specifications for inverter and mounting bracket dimensions.
2. Drill at least two holes and mount the bracket to the mounting surface. Verify that the bracket is firmly attached to the mounting surface.
3. Hang the inverter on the bracket. See Figure 17
 - a. Lift the inverter from the sides or hold it at the top and bottom.
 - b. Lower the inverter onto the U-shaped indentations of the mounting bracket. Position the inverter flat against the wall or a pole.

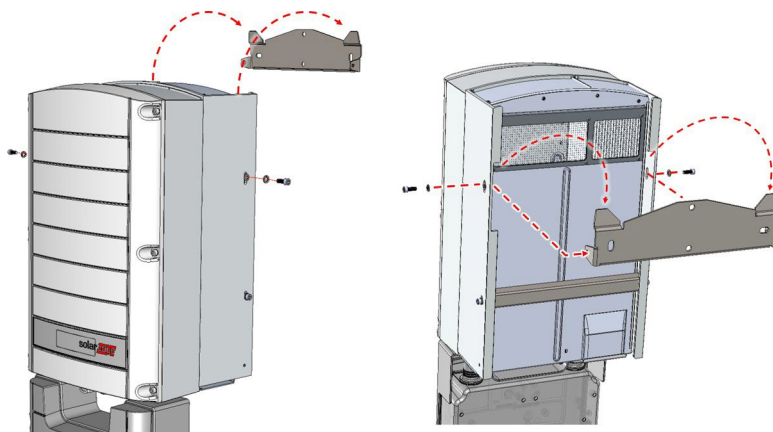

Figure 18: Hanging the inverter on the brackets

4. Mark the location of the drilling hole required for the screw that secures the bracket of the Connection Unit to the wall (See Figure 19) and remove the inverter from the wall.

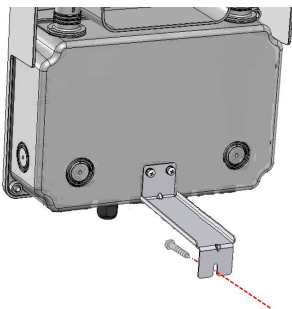

Figure 19: Securing the Connection Unit to the wall

5. Drill a hole for the screw anchor securing Connection Unit to the wall.

6. Hang the inverter on the bracket:
 - a. Lift the inverter from the sides, or hold it at the top and bottom. Do not lift holding the Connection Unit as it may be damaged.
 - b. Lower the inverter onto the U-shaped indentations of the mounting bracket. Let the inverter lay flat against the wall or pole.
 - c. Insert the two supplied screws through the outer heat sink fin on both sides of the inverter and into the bracket. Tighten the screws of 3.9N•m/2.9lbf•ft.
7. Secure the bracket that attaches the Connection Unit to the wall with a screw.
8. Verify that the inverter is firmly attached to the mounting surface.

Chapter 4: Connect AC and DC strings to the connection unit

The DC Disconnect Switch of the Connection Unit disconnects all ungrounded DC conductors in compliance with the National Electric Code (NEC; Specifically NEC690.35, which addresses ungrounded PV arrays). The Connection Unit is rated to the maximum operating conditions of the inverter. Inverters of different models are equipped with different sizes / types of terminal blocks. Figure 19 shows a Connection Unit with four DC pairs.

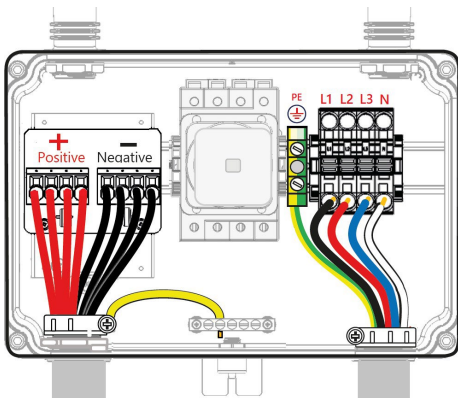

Figure 20: Connection Unit with four DC pairs

Grid connection guidelines

In most countries, three phase inverters require neutral connection. In some countries, three phase inverters can be connected to delta grids along with multiple single phase inverters inverters.



NOTE

If local regulations permit, the connection of Neutral is optional in a 4-wire system of three phase inverters.

- The conduits, hubs and fittings must be suited for field wiring systems.
- The hubs and other fittings must comply with UL514B.

- Use the conduit and wiring appropriate for the installation location per the NEC. Outdoor installations must use components that are rated NEMA 3R or higher.
- For grids supported by SolarEdge Inverters, see [Grids Supported by SolarEdge Inverters – Technical Note](#).
- For short-circuit currents in SolarEdge Three Phase , see [Short-Circuit Currents in SolarEdge Three Phase Inverters- Technical Note](#).
- Overcurrent Protection Device (OCPD) for the AC output is to be provided at the time of installation. Coordination of conductor sizes with overcurrent protection shall be in accordance with the applicable electrical code for your jurisdiction.

The inverter must be protected by an over-current protection device (a circuit breaker or a fuse) with a maximum rating of 80A.

- For the exact rating of an over-current protection device, per model, see: [Determining the Circuit Breaker Size - Application Note](#).



NOTE

For additional information about wiring, see [SolarEdge Recommended AC Wiring - Application Note](#).



Connect the PV strings to the connection unit of the inverter

Depending on the part number, you can connect a maximum number of 3 or 4 strings to the inverter. When connecting the PV strings to the inverter, use only 6 to 12 AWG wires.



CAUTION

- The PV inputs of the inverter are not intended for connection to a battery or any other type of DC source except a PV array.
- La connexion de fils en aluminium oxydé peut entraîner une résistance et des températures élevées aux points de contact.



NOTE

When installing a system with 3 or more strings per a single inverter (whether connected directly or via a combiner box), fuses may be required. For details, see [String Combiners in SolarEdge Systems, North America](#).

To connect multiple PV strings to the Connection Unit of the inverter:**NOTE**

Use copper wires with insulation rated for at least 90°C. Make sure to consider the maximum termination temperature at both ends of the conductor and to base the ampacity on the lower value.

1. Release the four screws and remove the cover of the Connection Unit.
2. Strip 0.7" (18 mm) of the DC wire insulation.

**NOTE**

Use only DC wires with a gauge of 6 to 12 AWG. When using a stranded wire, use of ferrule is at the installer discretion.

3. Insert the DC conduit into the open DC-side drill guide
4. Tighten the nut that secures the DC conduit to the Connection Unit.

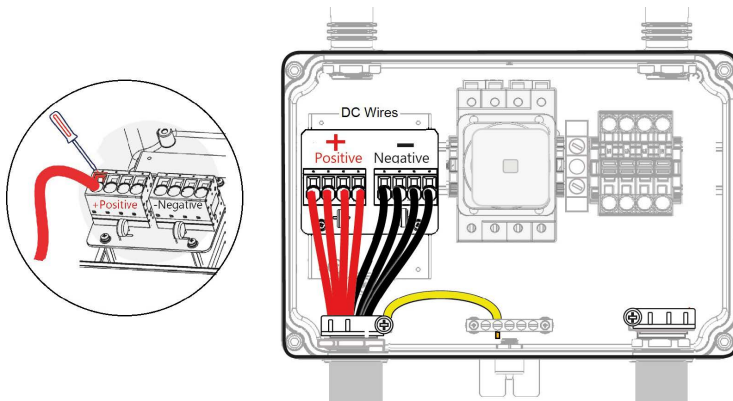

Figure 21: Connect the ground wire Inside the of the multiple PV strings inverter

**NOTE**

Functional Electrical Earthing of DC-side negative or positive is prohibited because the inverter has no transformer. Equipment grounding of exposed conductive surfaces in the array is required per the NEC.

5. Connect the DC wires of the PV array to the DC+ and DC- terminal blocks, according to the labels on the terminals:

**CAUTION**

- To avoid electrical damage to the inverter, connect the DC+ and DC- wire, of each string to their corresponding location on the terminal blocks. **DO NOT** mix string wires.
- D'éviter d'endommager électriquement l'onduleur, raccordez les fils DC+ et DC- de chaque chaîne à leur emplacement correspondant sur les borniers. **NE** mélangez **PAS** les fils + et - des chaînes.

- a. Use a standard flat-blade screwdriver to connect the wires to the spring-clamp terminals. The screwdriver blade should fit freely in the terminal opening. Too large a blade can crack the plastic housing.
- b. Insert the screwdriver and firmly tilt it to press the release mechanism and open the clamp.
- c. Insert the wire into the front opening.
- d. Remove the screwdriver – the wire is automatically clamped. Check that the wire is fully inserted and cannot be pulled out easily.

Connect the AC grid to the connection unit

The inverter can operate with connection of four wires (N, L1, L2, L3) and Protective Ground (PE) wire or three wires (L1, L2, L3) and PE wire connections. Use 6 to 10 AWG wires. When using a stranded wire, use of ferrule is at the installer discretion.

**WARNING**

- Turn OFF the AC before connecting wires to the Connection Unit of the inverter.
- Éteignez le courant alternatif avant de raccorder les chaînes à l'onduleur.

**WARNING**

- Connect Protective Ground before connecting the AC wires to the AC terminal blocks.
- Veillez à relier le conducteur de PE (la terre) avant de connecter les fils CA au bornier CA.

To connect AC grid to the Connection Unit:

1. Insert the AC conduit with the grid wires through the drilled hole in the Connection Unit and secure the conduit with a nut.

**NOTE**

Use copper wires with insulation rated for at least 90°C. Make sure to consider the maximum termination temperature at both ends of the conductor and to base the ampacity on the lower value.

2. Insert the AC conduit with the grid wires through the drilled hole in the Connection Unit and secure the conduit with a nut.
3. Strip 0.4 to 0.43" (10 to 11mm) of the PE wire insulation.

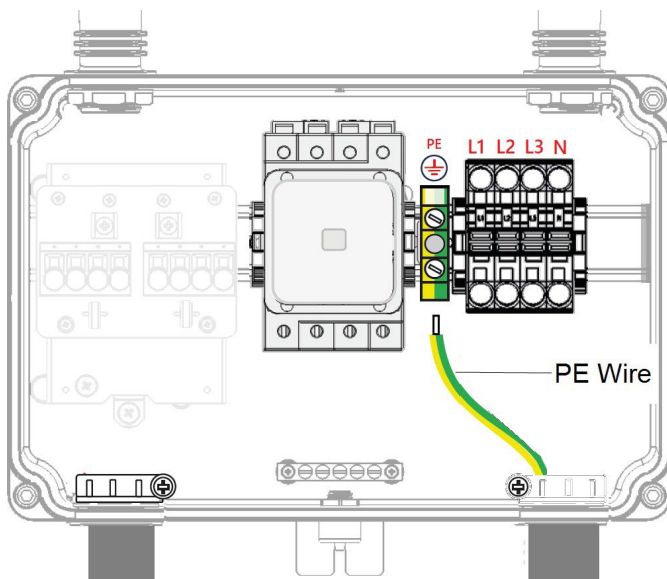

Figure 22: Connect PE wire to the PE terminal block inside the Connection Unit.

4. Insert the PE wire into the PE terminal and tighten the screw using a torque of 1.1 lbf•in.

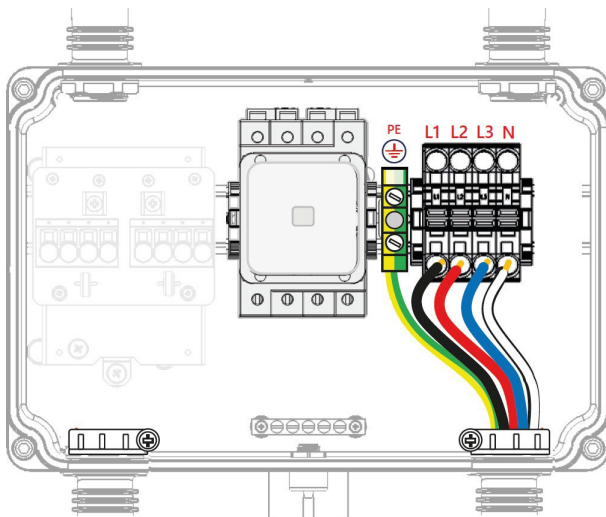

Figure 23: Connect the N, L1, L2, L3 wires to the terminal blocks inside the Connection Unit.

5. Strip 0.7" (18mm) of the N, L1, L2, L3 wires insulation.

6. Connect the wires to the appropriate terminal blocks according to the labels on the terminal blocks (N, L1, L2, L3):
 - a. Use a standard flat-blade screwdriver to connect the wires to the spring-clamp terminals.
 - b. The screwdriver blade should fit freely in the terminal opening. Too large a blade can crack the plastic housing.
 - c. Insert the screwdriver, press the release mechanism and open the clamp.
 - d. Insert the wire into the square opening and remove the screwdriver – the wire is automatically clamped.
7. Verify that all wires are properly connected and cannot be pulled out from the terminals.
8. Close the Connection Unit cover: Attach the Connection Unit cover and secure the four screws of 6.6 lbf•ft (7.6 lbf•ft for plastic screws) in a crossed pattern.
9. Ensure proper conduit sealing; inspect the entire conduit run and use standard conduit sealants to avoid water penetration.

Chapter 5: Set Up Communication with the Monitoring Platform

The monitoring platform allows access to PV site information including:

- Power Optimizer information received via the DC power lines (the PV output circuit)
- Inverter information
- Information of any other connected devices

This chapter describes how to set up communication between:

- The inverter and ONE for C&I through the Internet (wired/wireless)
- Multiple inverters for a leader-follower configuration

Communication setup is not required for power harvesting, however it is needed for using ONE for C&I.



CAUTION

- When connecting the communication cables, make sure that the P/1/0 switch on the inverter is turned OFF, the DC Disconnect Switch on the Connection Unit is turned OFF and the AC is turned OFF. When configuring the communication parameters, make sure that the P/1/0 switch on the inverter is OFF, and the AC is turned ON.
- Lors de la connexion des câbles de communication, assurez-vous que l'interrupteur MARCHE/ARRÊT à la base de l'onduleur soit en position ARRÊT, le sectionneur DC est éteint et le CA est en position ARRÊT. Lors de la configuration des paramètres de communication, assurez-vous que l'interrupteur MARCHE/ARRÊT soit en position ARRÊT, et le CA est en position MARCHE.

Communication Options

The following types of communication can be used to transfer site data through the inverter to the Monitoring platform.



NOTE

This guide refers to third party communication products, such as internet switches and routers that are not supported by SolarEdge. For detailed information on how to install and use the products, refer to the respective publication provided with each product.

External Communication Options

Ethernet: Ethernet is used for a LAN connection. For connection instructions refer to Creating an Ethernet (LAN) Connection on page 1.

Wi-Fi: The Wireless Gateway collects inverter data using a dedicated Wi-Fi. The inverter connects to the Monitoring platform via a home router. Wireless Repeater(s) extend the Wi-Fi signal range between the Wireless Gateway and inverter. Wireless Gateway and Wireless Repeaters can be purchased separately from SolarEdge. For more information, see <https://knowledge-center.solaredge.com/sites/kc/files/se-wireless-gateway-wireless-repeater-installation-guide.pdf>.

Cellular: Cellular Plug-in (purchased separately) provides cellular communication to connect one or several inverters to the Monitoring platform. Cellular communication depends on the purchased data plan.

Internal Communication Options

RS485:

RS485 is used for the connection of multiple SolarEdge devices on the same bus in a leader-follower configuration. RS485 can also be used as an interface to external devices, such as meters and third party data loggers.

- RS485-1: Enables the connection of multiple devices (inverters/Commercial Gateway) over the same bus, such that connecting only one device to the internet is sufficient to provide communication services for all the devices on the bus.
- RS485-2: Enables connection of multiple SolarEdge devices and of non-SolarEdge devices over the same bus.

Communication Connectors

Two communication glands are used to connect various communication options. Each gland has three openings. The table below describes the functionality of each opening. Unused openings should remain sealed.

The table below describes the openings of the communication glands of the Three Phase inverter.

Communication glands

Gland #	Opening	Functionality
Com 1	One small - 2- 4mm/0.08-0.16in	External antenna cable
	Two large - 4.5-7mm/0.18-0.27in	Ethernet connection (CAT6) or cellular
Com 2	All three large -2.5-5mm/0.1-1.2in	RS485

The communication board has a standard RJ45 terminal block for Ethernet connection, and a 6-pin terminal block for RS485 connection, as shown below:

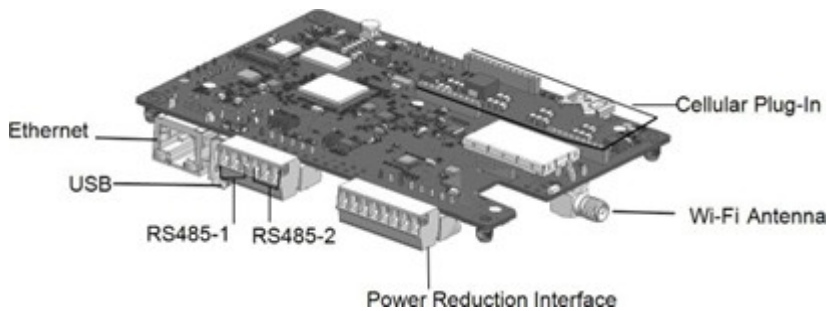

Figure 24: Internal communication connectors

Remove the inverter cover

To remove the inverter cover:

1. Turn OFF the P/I/O switch of the inverter
2. Wait for at least five minutes for the DC voltage inside the inverter to drop to a safe level.



NOTE

Before doing any maintenance work on the inverter, test for safe AC and DC voltages.

3. Turn OFF the DC Disconnect switch of the inverter.
4. Disconnect the AC to the inverter by turning OFF the circuit breakers on the distribution panel.
5. Release the six Allen screws holding the inverter cover and remove the cover.

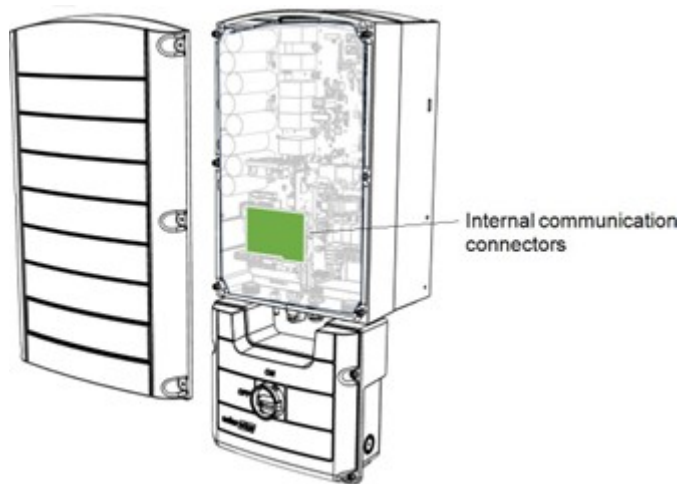

Figure 25: Access the inverter communication connectors



CAUTION

- When removing the inverter cover, make sure not to damage the internal components. SolarEdge will not be held responsible for any components damaged as a result of incautious cover removal.
- Lors du retrait du couvercle, assurez-vous de ne pas endommager les composants internes. SolarEdge ne peut être tenue pour responsable des composants endommagés à la suite d'une imprudence dans le retrait du couvercle.

Remove the Connection Unit cover

1. Switch off the AC circuit breaker on the main distribution panel and the safety switch (if applicable).



CAUTION

- When removing the DC Safety Unit cover, make sure not to damage the internal components. SolarEdge will not be held responsible for any components damaged as a result of incautious cover removal.
- Lors du retrait du couvercle, assurez-vous de ne pas endommager les composants internes. SolarEdge ne peut être tenue pour responsable des composants endommagés à la suite d'une imprudence dans le retrait du couvercle.

2. Open the DC Safety Unit cover: Release the four Allen screws and remove the cover.

Create a Local Area Network (LAN) connection

This communication option enables using an Ethernet connection to connect the inverter to the monitoring platform via LAN.

Ethernet cable specifications:

- Cable type – a shielded Ethernet cable (CAT6 may be used).
- Maximum distance between the inverter and the router – 100 m / 330 ft

**NOTE**

If using a cable longer than 10 m / 33 ft in areas where there is a risk of induced voltage surges by lightning, it is recommended to use external surge protection devices. For details, see [Overvoltage Surge Protection–Technical Note](#).

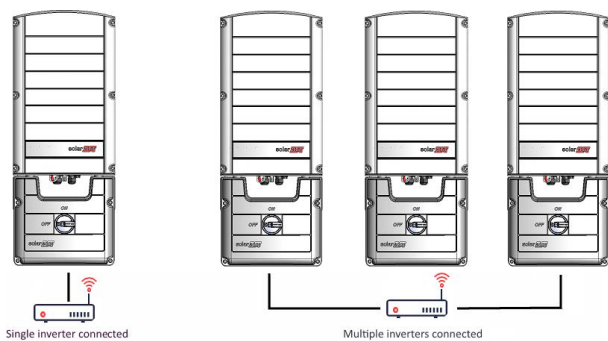

Figure 26: Example of Ethernet connection

To connect the Ethernet cable:

1. Remove the inverter cover and wait at least five minutes for the DC voltage inside the inverter to drop to a safe level. For details, see [Removing the Inverter Cover](#).

**NOTE**

Before doing any maintenance work on the inverter, test for safe AC and DC voltages.

2. Open the communication gland #1.

**CAUTION**

- The gland includes a rubber waterproof fitting, which should be used to ensure proper sealing.
- Le cote interne du gland contient une rondelle qui doit être utilisée pour une bonne étanchéité.

3. Remove the plastic seal from one of the large openings.
4. Remove the rubber fitting from the gland and insert the CAT6 cable through the gland and through the gland opening in the inverter.

5. Push the cable into the cut opening of the rubber fitting.

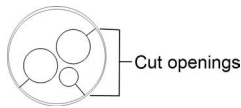

Figure 27: Rubber fitting

CAT6 standard cables have eight wires (four twisted pairs), as shown in the diagram below. Wire colors may differ from one cable to another. You can use either wiring standard, as long as both sides of the cable have the same pin-out and color-coding.

Standard cable wiring

RJ45 Pin #	Wire color		10Base-T Signal
	T568B	T568A	100Base-TX Signal
1	White/Orange	White/Green	Transmit+
2	Orange	Green	Transmit-
3	White/Green	White/Orange	Receive+
4	Blue	Blue	Reserved
5	White/Blue	White/Blue	Reserved
6	Green	Orange	Receive-
7	White/Brown	White/Brown	Reserved
8	Brown	Brown	Reserved

6. Use a pre-crimped cable to connect via gland #1 to the RJ45 plug on the inverter's communication board or, if using a spool of cable, connect as follows:
 - a. Insert the cable through gland #1.
 - b. Remove the cable's external insulation using a crimping tool or cable cutter and expose eight wires.
 - c. Insert the eight wires into an RJ45 connector, as described in Figure 27.
 - d. Use a crimping tool to crimp the connector.
 - e. Connect the Ethernet connector to the RJ45 port on the communication board.

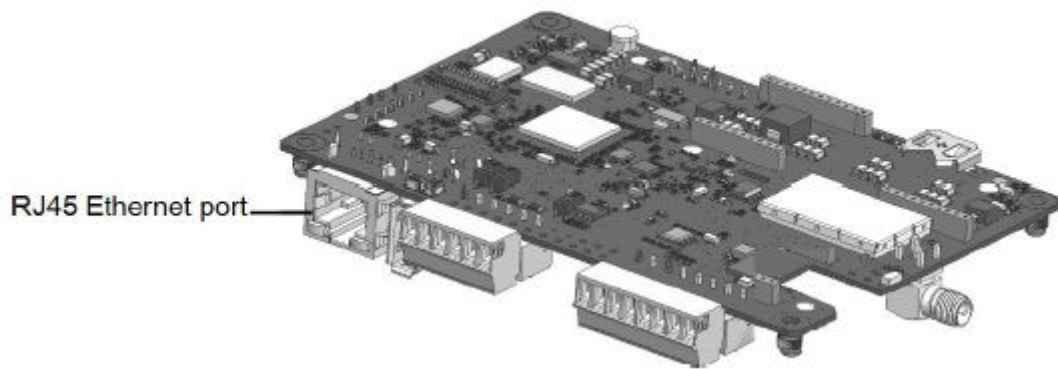

Figure: RJ45 Ethernet connection

7. For the switch/router side, use a pre-crimped cable or use a crimper to prepare an RJ45 communication connector: Insert the eight wires into the RJ45 connector in the same order as above (Figure 27).
8. Connect the cable RJ45 connector to the RJ45 port of the Ethernet switch or router. You can connect more than one inverter to the same switch/router or to different switches/routers, as needed. Each inverter sends its monitored data independently to the monitoring platform.
9. The inverter is configured by default to LAN. If reconfiguration is required:
 - a. Make sure the P/I/O switch is OFF.
 - b. Turn ON the DC Disconnect Switch.
 - c. Turn ON the AC to the inverter by turning ON the circuit breaker on the main distribution panel.
 - d. Configure the connection as described in Communication on page 66.



NOTE

- If your network has a firewall, you may need to configure it to enable the connection to the following address:
 - Destination Address: prodssl.solaredge.com
 - TCP Port: 443 (for incoming and outgoing data)

10. Verify the connection, as described in the section, Verifying the Connection.

Create an RS485 bus connection

The RS485 option enables creating a bus of connected inverters, consisting of up to 31 follower inverters and 1 leader inverter. Using this option, inverters are connected to each other in a bus (chain), via their RS485 connectors. The first and last inverters in the chain must be terminated.

RS485 wiring specifications:

- Cable type: CAT6, Belden
- Maximum nodes: 32
- Maximum distance between the first and last devices: 1km/3300ft

**NOTE**

If grounded metal conduits are used for routing the communication wires, a lightning protection device is not required.

To connect the RS485 communication bus:

1. Release the six Allen screws and carefully remove the DC Safety Unit cover.
2. Remove the seal from one of the openings in communication gland #2 and insert the wire through the opening.
3. Pull out the 6-pin RS485 terminal block connector, as shown in Figure 29.

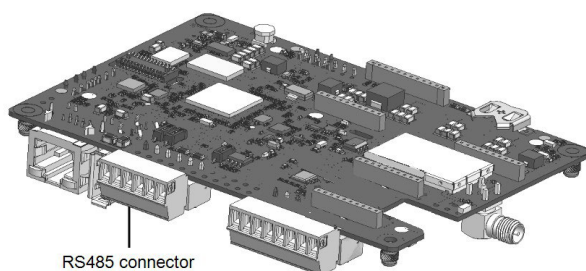

Figure 28: RS485 terminal block on the communication board

4. Loosen the screws of pins A(+), B(-), and G on the left of the RS485 terminal block (RS485-1 or RS485-2).

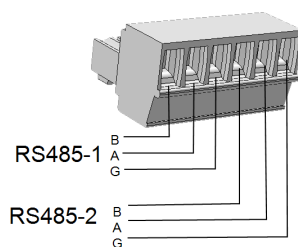

Figure 29: RS485 terminal block

5. Insert the wire ends into the G, A and B pins shown above. Use Four- or six-wire twisted pair cable for this connection. You can use any color wire for each of the A, B, and G connections, as long as:
 - The same color wire is used for all A pins the same color for all B pins and the same color for all G pins.
 - The wire for G is not from the same twisted pair as A or B.
6. For creating an RS485 bus - connect all B, A and G pins in all inverters. The following figure shows this connection schema:

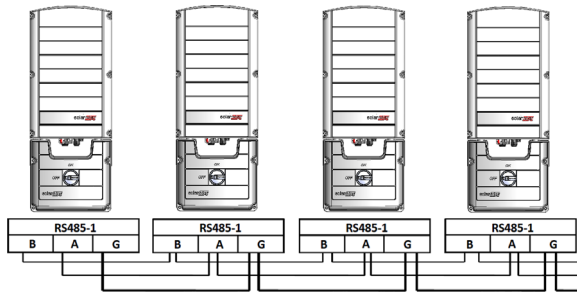

Figure 30: Connect the inverters in a chain



NOTE

Do not cross-connect B, A, and G wires.

7. Tighten the terminal block screws.
8. Check that the wires are fully inserted and cannot be pulled out easily.
9. Push the RS485 terminal block firmly all the way into the connector on the right side of the communication board.
10. Terminate the first and last SolarEdge device in the chain by switching a termination DIP-switch inside the inverter to ON (move the left switch up). The DIP-switch is located on the communication board and is marked SW1.

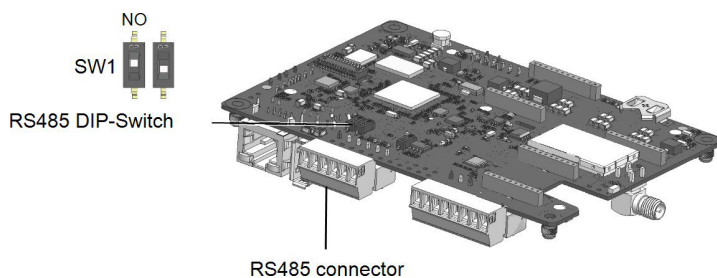

Figure 31: RS485 termination DIP-switch (SW1)



NOTE

Only the first and last SolarEdge devices in the chain should be terminated. The other inverters in the chain should have the termination switch OFF (down position).

11. Tighten the nut of the COMM2 gland to a torque of 3 lbf·ft.

RS485 Bus Configuration

To connect to the Monitoring platform:

1. Designate a single inverter as the connection point between the RS485 bus and the monitoring platform. This inverter will serve as the leader inverter
2. Connect the leader to the monitoring platform by establishing an internet connection.

To configure the RS485 bus:

All inverters are configured by default as followers. The leader is the inverter connected to the network and the one that an energy meter **MUST** be connected to.

To configure the leader:

1. Make sure the inverter's P/I/O switch is OFF.
2. Make sure that the AC circuit breaker on the main distribution panel is on.
3. Access SetApp, as described in Communication on page 78.
4. From the Commissioning screen, select **Site Communication > RS485-1 > Protocol > SolarEdge > SolarEdge Leader**.
5. Return to the RS485-1 screen and select **Follower Detect**.

The system starts automatic detection of the follower inverters connected to the leader inverter. The inverter should report the correct number of followers. If it does not, verify the connections and terminations in all inverters in the chain.

6. To check the follower IDs and last communication time, select **RS485-1 > Follower List**.
7. Verify the connection of the leader to the Monitoring platform, as described below.

Verify the connection

After connecting and configuring a communication option, perform the following steps to check that the connection to the Monitoring platform has been successfully established.

1. If the DC Safety unit cover is not closed, close it: Attach the DC Safety unit cover and secure it by tightening the screws of 2.6 lbf•ft. For proper sealing, first tighten the corner screws and then the two central screws.
2. Commission the inverter as describe in Activate, commission, and configure the system.
3. Access SetApp and select **Status** from the **Configuring** screen.
4. In the **Summary** section, under **Server Comm.**, make sure **S_OK** is displayed together with the selected communication option.
5. Scroll down to the **Communication** section and check that the communication options are as required.

Chapter 6: Activating, Commissioning and Configuring the System

After the solar system is installed, it is important to activate and commission the solar system. Activation and commissioning of the system is performed using the inverter SetApp mobile application.

During the activation and commissioning, the inverter discovers and communicates with all connected components in the solar system, such as: optimizers, peripheral communication devices and other linked inverters. When commissioning is performed, the user is required to set the grid parameters and backup Voltage information (if used). Before starting the activation and commissioning, verify all the communication hardware is properly connected. Before arriving at the site, download SolarEdge SetApp application to your mobile device from Apple App Store or Google Play .



For downloading SetApp, Internet connection, one-time registration and log in are required.



NOTE

It is possible to perform DC commissioning on the inverters before completing the AC connection to the electrical grid. DC commissioning, also referred to as "commissioning from the sun", is performed in daylight using SolarEdge SetApp mobile application.

Step 1: Activate the Installation

During system activation, a Wi-Fi connection is created between the mobile device and the inverter, and the system firmware is upgraded.

Before you begin:

- Download, register (first time only) and login to SetApp on your mobile device.
- Verify that the application is updated with the latest version.

- If applicable, turn on all devices (Energy Meter, Backup Interface) connected to the inverter, so that the devices may be auto detected.

To activate the inverter:

1. Turn ON the AC circuit breaker on the main distribution panel.
2. Turn ON the DC Disconnect switch (if applicable).
3. Open SetApp and follow the on-screen instructions (scan the inverter barcode; move the P/1/0 switch to P position for 2 seconds and release).

SetApp creates a Wi-Fi connection, upgrades the inverter firmware and activates the inverter.

4. Select the relevant inverter model (AC power class), if applicable. The inverter is activated and the firmware automatically updates during this process. For details, see [Power class selection \[57\]](#).
5. When the activation is complete, do one of the following:
 - Select **Connect to Another Device** to continue activating additional inverters.
 - Select **Start Commissioning** for pairing and other system configuration.



NOTE

When commissioning a Leader inverter, from the Commissioning screen select the Central Commissioning for fast and simple commissioning powered by a wizard.

Step 2: Commissioning and Configuring the Installation

This section describes how to use the SetApp menus for commissioning and configuring the inverter settings. Menus may vary in your application depending on your system type.

To access the Commissioning screen, do one of the following:

- During first time installation: Upon activation completion, the commissioning process will continue automatically. follow SetApp instructions

OR

- If the inverter has already been activated and commissioned:
 - If it is not already ON, turn ON AC to the inverter by turning ON the circuit breaker on the main distribution panel.
 - Open SetApp and follow the on-screen instructions (scan the inverter QR code, move the P/1/0 switch to P position for 2 seconds and release).

The mobile device creates a Wi-Fi connection with the inverter and displays the main Commissioning screen.

Setting Country, Grid and Language

The inverter must be configured to the proper settings in order to ensure that it complies with the country grid code and functions. Unless these settings are selected, the inverter will not start production.

1. From the Commissioning screen, select Country&Grid.
2. From the Country Grid drop-down list, select the required option and tap Set Country > Grid.
3. If relevant, from the Language drop-down list, select your language and tap Set Language.
4. To save the information to a read-only file, tap the PDF icon (iOS) or the JPEG icon (Android) at the bottom of the screen.

Power class selection

For some inverters, the model and power class of the inverter must be chosen during commissioning. Peel off the tab next to the selected inverter model to indicate the chosen model.

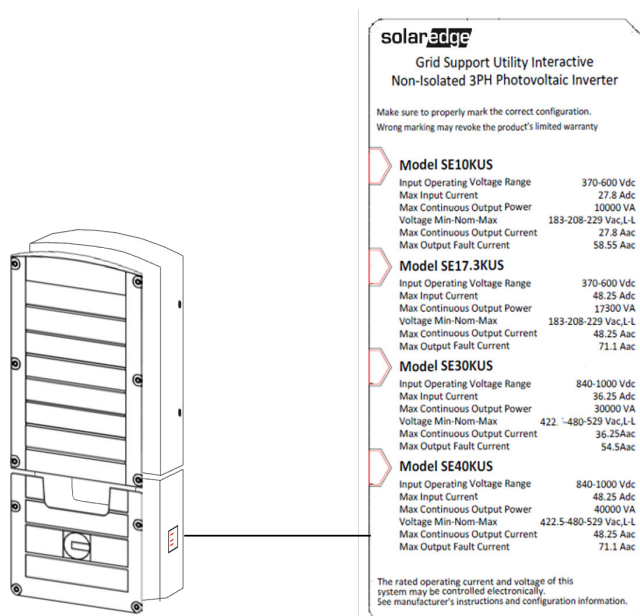

Figure 34: The inverter label is located on the side of the inverter.

In SetApp, you are prompted to set the inverter model too.

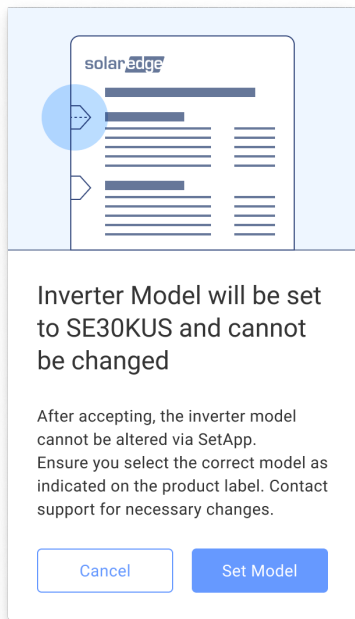
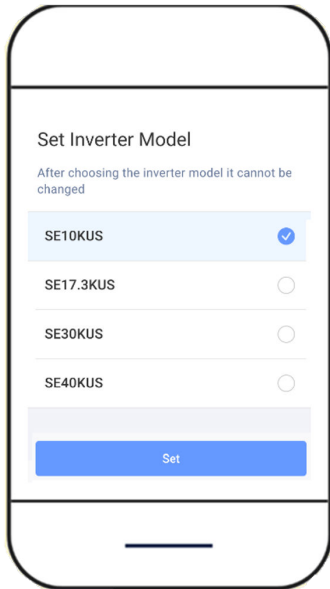

Figure 35: Set the inverter model in SetApp.



NOTE

The selected model must align with the approved project plan and installed OCPD devices.

**NOTE**

After selecting the model in SetApp, you cannot change it without contacting SolarEdge support.

Pairing

Once all connections are made, all the Power Optimizers must be paired with the inverter. This section describes how to assign the Power Optimizers to the inverter. The pairing process takes place during the first activation of the inverter. The pairing process is automatically triggered after the commissioning process. In some cases, where Power Optimizers are replaced, proactive pairing process is required.

To activate the proactive pairing process:

1. From the Commissioning menu, select Pairing.
2. Tap Start Pairing.
3. When Pairing Complete is displayed, the system startup process begins:

Since the inverter is ON, the Power Optimizers start producing power and the inverter starts converting AC.

**WARNING**

- When you turn ON the P/1/0 switch, the DC cables carry a high Voltage and the Power Optimizers no longer output a safe output.
- Après avoir mis l'interrupteur P/1/0 de l'onduleur monophasé sur ON, les câbles DC portent une haute tension et les optimiseurs de puissance ne génèrent plus la tension de sécurité

When the inverter starts converting power after the initial connection to the AC, the inverter enters Wake up mode until its working voltage is reached. This mode is indicated by the flickering green inverter LED. When working voltage is reached, the inverter enters Production mode and produces power. The steadily lit green inverter LED indicates this mode.

4. Tap OK to return to the Commissioning menu.

Communication

Communication settings can be configured only after communication connections are complete.

- From the Commissioning menu, select Monitoring Communication > Auto Select. SetApp will automatically detect your connection method. Follow the on-screen instructions to complete the configuration and establish communication with the monitoring platform.

- From the Commissioning menu, Select Site Communication to configure communication between multiple SolarEdge devices or external non SolarEdge devices, such as batteries or data loggers.

For more information on the Monitoring Platform, refer to the C&I One User Guide available on the SolarEdge website at: <https://knowledge-center.solaredge.com/sites/kc/files/solaredge-monitoring-portal-user-guide.pdf>

Power Control

For P_Q diagram, see: https://knowledge-center.solaredge.com/sites/kc/files/application_note_power_control_configuration.pdf



NOTE

SolarEdge inverters with "Grid Support" functionality (as marked on the inverter certification label), are compliant with UL 1741 Supplement B. The functionality is built into the inverter and no additional external device is required.

Verifying Proper Activation and Commissioning

1. Select **Information** and verify that the correct firmware versions are installed on each inverter.
2. Select **Status** and verify that inverter is operating.
3. Verify that additional configurations were properly set by viewing the relevant Status screens.
4. Verify that the green inverter LED is steadily lit

Your SolarEdge power harvesting system is now operational.

Reporting and Monitoring Installation Data

Monitoring the site requires connecting the inverter to the monitoring platform, using any of the wired or wireless options available from SolarEdge.

SolarEdge ONE for C&I

The monitoring platform provides enhanced PV performance monitoring and inverter yield assurance through immediate fault detection and alerts at the module, PV array and system level.

Using the platform, you can:

- View the latest performance of specific components.
- Find under-performing components, such as modules, by comparing their performance to that of other components of the same type.
- Pinpoint the location of alerted components using the physical layout.

**NOTE**

The Monitoring platform enables accessing site information, including up-to-date information viewed in a physical or logical view:

- **Logical Layout:** Shows a schematic tree-layout of the components in the system, such as: inverters, Power Optimizers, PV arrays, modules, meters, and sensors, as well as their electrical connectivity. This view enables you to see which modules are connected in each PV array, which PV arrays are connected to each inverter, and so on.
- **Physical Layout:** Provides a bird's eye view of the actual placement of modules in the site and allows pinpoint issues to the exact location of each module on a virtual site map.

If you do not report the mapping of the installed Power Optimizers, the Monitoring platform will show the logical layout, indicating which Power Optimizers are connected to which inverter, but will not show PV strings or the physical location of Power Optimizers. The Monitoring platform includes a built-in help system that guides you through the monitoring functionality.

For more information, refer to <https://www.solaredge.com/en/products/software-tools/monitoring-platform>.

Creating Logical and Physical Layout using Installation Information

To display a logical layout, insert the inverter in the new site created in the Monitoring platform. When the communication between the inverter and the monitoring server is established, the logical layout is displayed.

To display a physical layout, you need to map the locations of the installed power optimizers. To map the locations, use one of the methods described in the next sections.

Designer

Designer recommends inverter and Power Optimizer selection per site size and enables report generation. You can create a project in Designer and export the site design with the PV array layout to the monitoring platform.

For more information, refer to [https://www.solaredge.com/products/installer- tools/ designer#/](https://www.solaredge.com/products/installer-tools/designer#/).

Physical Layout Editor

1. If you are a registered installer, access the Monitoring platform site creation page at <https://monitoring.solaredge.com/solaredge-web/p/home#createSites>. If you have not yet signed up, go to https://monitoringpublic.solaredge.com/mfe/registration/?locale=en_US
2. Fill out all the required information in the screen, which includes information about your installation.

Appendix A: Errors and troubleshooting

This chapter describes how to troubleshoot general system problems. For further assistance, contact SolarEdge Support.

Identify errors

Errors may be indicated in various system interfaces: On the inverter bottom panel, a red LED indicates an error. In the monitoring platform and SetApp, errors are displayed with codes. For more information on the codes displayed for error and warning messages, see [Troubleshooting SolarEdge Systems, Addendum \(North America\)](#).

This document describes the errors and alerts that appear in SetApp, and the Monitoring Platform and the way of troubleshooting them. To identify the error types, use the methods described below.

To identify the error type using the inverter LEDs:

1. Move the P/1 /0 switch to P position for 2 seconds and release it.
2. Observe the LED lights and use the following table to identify the error type. For more information, see <https://www.solaredge.com/us/leds>.

LED status

Error type	Inverter LED color and state		
	Red	Green	Blue
Arc detected	ON	OFF	OFF
Isolation or RCD problem	Blinking	OFF	OFF
Grid error	OFF	ON	OFF
High temperature	OFF	Blinking	OFF
Pairing failed	OFF	OFF	ON
Other issue	OFF	OFF	Blinking

To identify the error type using the Monitoring platform:

1. Open the site dashboard and click the Layout icon.
2. Right-click the inverter and select **Info** from the menu. The inverter details window is displayed.
3. Click the **Errors** tab. The list is displayed.

Troubleshoot communication issues

Troubleshoot Ethernet (LAN) communication

The possible errors and their troubleshooting are detailed in the following table:

Troubleshooting error messages

Error message	Possible cause and troubleshooting
LAN cable disconnected	Physical connection fault. Check the cable pin- out assignment and cable connection.
No DHCP	IP settings issue. Check the router and configuration. Consult your network IT.
Configure Static IP or set to DHCP	
Gateway not responding	Ping to router failed. Check the physical connection to the switch/ router. Check that the link LED at the router / switch is lit (indicating phy-link). If OK - contact your network IT, otherwise replace the cable or change it from cross to straight connection.
No Internet connection	Ping to google.com failed. Connect a laptop and check for internet connection. If internet access is unavailable, contact your IT admin or your internet provider.

Troubleshoot communication

If after follower detection the number of followers displayed for the leader under > Follower is lower than the actual number of followers, refer to the following application note to identify missing followers and troubleshoot connectivity problems: [Troubleshooting Undetected RS485 Follower Devices - Application Note](#).

Additional troubleshooting

1. Check that the modem or hub/router is functioning properly.
2. Check that the connection to the internal connector on the communication board is properly done.
3. Check that the selected communication option is properly configured.
4. Use a method independent of the SolarEdge device to check whether the network and modem are operating properly. For example, connect a laptop to the Ethernet router and connect to the Internet.
5. Check whether a firewall or another type of network filter is blocking communication.

Isolation fault

In photovoltaic systems with a transformer-less inverter, the DC is isolated from ground or a faulty inverter, can cause a leakage of DC current to the ground (PE - protective earth). Such a fault is also called an isolation fault or ground fault. To identify and locate an isolation fault in a PV system, see [SolarEdge Isolation Fault Troubleshooting - Application note](#).

Troubleshoot Power Optimizer issues

For detail about Power Optimizer troubleshooting see the following:

- [SolarEdge Isolation Fault Troubleshooting - Application note](#)
- [Power Optimizer and String Troubleshooting Guide – North America](#)

Appendix B: Add optional components

Add AC Surge Protection Device (SPD)

The AC SPD is a device designed to protect the inverter from Voltage spikes and surge attempts forming on the AC grid lines. The SPD limits the Voltage supplied to the inverter by either blocking or shorting to ground Voltages above a safe threshold. The SPD is installed inside the inverter and communicates with the SolarEdge Monitoring platform for reporting surge protection events and faults. For installation and configuration of AC SPD, see: [Installation of AC Surge Protection Device in Three Phase Inverters](#).

Add DC Surge Protection Device (SPD)

The DC SPD is a device designed to protect the inverter from Voltage spikes and surge attempts, forming on the PV DC lines, mainly induces by lightning. The SPD limits the Voltage supplied to the inverter by either blocking or shorting to ground Voltages above a safe threshold. The SPD is installed inside the inverter and communicates with the SolarEdge Monitoring platform for reporting surge protection events and faults. For installation and configuration of DC SPD, see: [Installation of DC Surge Protection Device in Three Phase Inverters](#).

Appendix C: Maintenance

This appendix describes how to perform preventive maintenance to the inverter. By performing these preventive maintenance tasks, you can help keep the inverter functioning properly and avoid potential problems.

Routine maintenance of the inverter

Perform a yearly mechanical inspection of the mounted solar inverter to ensure its proper and efficient functioning, and prolonging its lifespan.

Visual inspections

By performing these inspection steps, you can help ensure that your inverter is installed safely:

1. Check the mounting of the inverter: Check that the mounting brackets of the inverter are secured to the wall and not showing signs of wear or damage or corrosion. Make sure that the inverter is firmly installed.

2. Inspect the physical condition: Inspect the physical condition of the inverter enclosures. Check for cracks, dents, and other physical damage. Ensure that all screws securing the front panel are in place.
3. Check the ventilation: Check that the cooling fan, at the bottom of the inverter, operate and that air can freely flow around the inverter.
4. Check the conduit connections: Inspect the physical condition of the conduits. Ensure that conduits are secured properly to the inverter, and to the wall.
5. Check the wiring glands: Check that the unused openings in the communication glands, at the bottom of the Inverter, are sealed.
6. Check the wiring: Check that the communication cables are not damaged. If cables are disconnected, immediately power-off the inverter.
7. Checking Ground Connections: Check that the Ground (PE) wire is tightly connected to all enclosure of the inverter.

Ground connection

The following process should only be done by a qualified electrician or someone with the proper training and equipment to avoid electrical hazards. To check a proper connection of a ground wire to the inverter, perform the following steps:

1. Ensure that the Ground (PE) wire is connected to the designated location on the enclosure of inverter.
2. Use a continuity tester to check the continuity between the ground wire, inverter's enclosure, metal conduits, and the earth. The tester should indicate a continuous circuit.

Fan maintenance

Each inverter has a cooling fan at can be accessed from the bottom panel of the enclosure. Keep the fan clean and free of dust. When needed, and at least once a year, open the fan screen and clean the accumulated dust using a brush. Check the fan to make sure it is functioning properly and is free of dust and debris. A dirty fan can cause the inverter to overheat, reducing its efficiency.

1. Turn 1/0/P switch of the inverter to OFF (0).
2. Turn OFF the DC Disconnect Switch on the front cover of the Connection Unit of the inverter and the AC breaker on the distribution panel.
3. Unscrew and remove the two Thumb Screws securing the Fan Assembly to the inverter (see Figure 35).
4. Pull out the Fan Assembly from within the inverter.
5. Clean the accumulated dust on the fan and screen using a brush. install the Fan Assembly and secure the Thumb Screws.
6. Turn ON the AC circuit breaker on the distribution panel.
7. Turn ON (1) the 1/0/P switch of the inverter.

8. Turn ON the DC Disconnect switch on the front cover of the Connection Unit.
9. Use the SetApp mobile application to connect to the inverter and follow the on- screen instructions. From the Commissioning screen, tap Status and check that Fan OK is displayed in the Status screen.

Wire Connections

Follow this procedure for maintaining the wire connections of the inverter:

1. Turn P/1/0 Switch of the inverter to OFF (0) and wait at least five minutes for the DC voltage inside the inverter to drop to a safe value before preceding to the next step.
2. Turn OFF the DC Disconnect Switch on the on the front cover of the Connection Unit of the inverter and turn OFF the AC circuit breaker on the distribution panel.
3. Remove the front cover of the Connection Unit.
4. Inspect the wire connections: Visually inspect all wire connections, looking for signs of damage, wear and tear, loose connections or overheating. If you find any signs of damage, it's important to address them promptly to prevent further issues.
5. Ensuring tight DC connections: Gently hold each wire and try to pull it out from each spring-clamped terminal. Verify that all wires are locked inside the terminals.
6. Ensuring tight AC connections: Gently hold each wire and try to pull it out from each spring-clamped terminal. Verify that all wires are locked inside the terminals.
7. Ensuring tight PE wire connection: Fasten the screw of the PE terminal to a torque of 1.1 lbf•in.
8. Check the wire insulation: Inspect the insulation on all wires for any signs of damage, such as cracks, overheating or abrasions. If you find any issues, repair or replace the wire as necessary.
9. Attach the Connection Unit cover and secure the four screws to 6.6 ftf•lb (7.6 ftf•lb for plastic screws) in a crossed pattern.
10. Turn ON the AC circuit breaker on the distribution panel.
11. Turn ON(I) the P/1/0 Switch of the inverter.
12. Turn ON the DC Disconnect Switch on the front cover of the Connection Unit.

General cleaning

Clean the inverter: Dirt and debris can accumulate on the inverter over time, which can reduce its performance. Clean the inverter regularly with a soft brush, a soft cloth, and mild detergent to keep it functioning efficiently.

Monitor the solar system performance

The SolarEdge Monitoring platform enables PV strings connected to the inverter. It provides accurate information about the present and past performance of each PV module individually and the system as a whole. The platform enables to detect, pinpoint

and troubleshoot faults, efficiently manage maintenance operations, and analyze site profitability.

Smart algorithms continuously track the power, Voltage, and current of all PV modules and inverters, as well as a range of statistical indicators to detect performance events that require intervention or maintenance.

If you are experiencing alerts from the SolarEdge monitoring system, it may indicate an issue with the PV modules, inverter, or the monitoring system itself. Some common alerts include:

1. **Panel mismatch:** This alert occurs when the performance of one or more panels in the solar array is not matching the expected performance. This could be due to shading, soiling, a malfunction, or other factors that are affecting the performance of the panel. To learn more on generating a PV module mismatch report, see [Monitoring Platform Mismatch Analysis Report - Application Note](#).
2. **Inverter failure:** This alert occurs when the inverter, which is responsible for converting the DC power generated by the PV modules into AC power has failed. To learn more on viewing alerts in the Monitoring platform, see: [Application Note – Alerts in the Monitoring Platform](#).
3. **Communication failure:** This alert occurs when the monitoring system is unable to communicate with the SolarEdge inverter. This could be due to a problem with the inverter itself, or with the communication network that connects the monitoring system to the inverter. It's important to address these alerts promptly to ensure the proper functioning of the system. If you're unsure how to address a specific alert, it may be helpful to contact SolarEdge support for assistance.

Appendix D: Interconnection standards

The information in this appendix complies with the IEEE 1547-2018 standard. The IEEE 1547-2018 standard, establishes criteria and requirements for interconnection of distributed energy resources (DER) with electric power systems (EPS) and associated interfaces.

Performance categories and interconnection standards

Performance criteria

Category/Standard	Description
A ¹ , B	Normal Operating Performance Category
3	Abnormal Operating Performance Category
1 ¹ ,2 ¹	Additional Abnormal Categories

Category/Standard	Description
UL 1741 Ed. 3 (SA), UL 1741 Ed. 3 (SB), IEEE 1547-2018, IEEE 1547.1- 2020, IEEE 1547a-2020, IEEE 1547.1 2020 SRD 2.0 (HECO), CA Rule 21 2017, CSA 22.3 No 9	Interconnection Standards

¹Units meet the highest performance category B, 3 and may be configured to operate at lower categories if required by the EPS.

Utility authorization is required to change abnormal voltage and frequency set-points. Response to abnormal conditions and unintentional islanding results in a disconnect of the equipment from the area EPS.

Response to Abnormal Voltages and Frequencies

Settings for abnormal voltages and frequencies

Default setting		Adjustable range	
Voltage(p.u.)	Maximum clearing time (sec)	Voltage (p.u.)	Clearing times
1.20	0.16	1.2	0.16
1.10	13.0	1.10-1.20	1.0-13.0
0.88	21.0	0.0-0.88	21.0-50.0
0.50	2.00	0.0-0.50	2.0-21.0
Frequency (Hz)	Maximum clearing time (sec)	Frequency (Hz)	Clearing times (sec)
62.00	0.16	61.8-66.0	0.16-1000
61.2	300	61.0-66.0	180-1000
58.5	300	50.0-59.0	180-1000
56.5	0.16	50.0-57.0	0.16-1000

Utility authorization is required to change abnormal voltage and frequency set-points. Response to abnormal conditions and unintentional islanding results in a disconnect of the equipment from the area EPS.

Enter Service settings

Service settings

Function	IEEE 1547 Default Settings ¹	Range
Enter Service Delay	300 ²	0-1000 seconds

Function	IEEE 1547 Default Settings ¹	Range
Enter Service Ramp Period	100	1-1000 seconds
Minimum voltage	0.917	0.88-0.95 p.u.
Maximum voltage	1.05	1.05 -1.05 p.u.
Minimum frequency	59.5	59.0-59.9 Hz
Maximum Frequency	60.1	60.1-61.0 Hz

¹Settings will be specified by the regional EPS (electric power system) operator.

²Changes to this setting should not be made without approval from the area EPS operator.

Grid support functions

Grid support functions

Function	IEEE 1547 Default Settings ¹	Range
Constant Power Factor mode	1	0-1
Constant Reactive Power mode	Disabled	+/- 1 nameplate Var p.u.
Voltage-Reactive Power mode	Disabled	
V2	0.98	0.92 -1.05 V p.u.
Q2	0	+/- 1 nameplate Var p.u.
V3	1.02	0.95 -1.08 V p.u.
Q3	0	+/- 1 nameplate Var p.u.
V1	0.92	0.77-1.03 V p.u.
Q1	0.44	0-1 nameplate Var p.u.
V4	1.08	0.97-1.23 V p.u.
Q4	-0.44	(-1)-0 nameplate Var p.u.
OLRT	5	1-90 seconds
Active Power-Reactive Power mode ¹	Disabled	
P3	1	0.5-1 nameplate power p.u.
P2	0.5	0.4-0.8 nameplate power p.u.
P1	0.2	0-0.7 nameplate power p.u.

Function	IEEE 1547 Default Settings ¹	Range
P'1	-0.2	-0.7-0 nameplate load p.u.
P'2	-0.5	-0.4-(-0.8) nameplate load p.u.
P'3	-1	-1-(-0.5) nameplate load p.u.
Q3	-0.44	+/- 1 nameplate Var p.u.
Q2	0	+/- 1 nameplate Var p.u.
Q1	0	+/- 1 nameplate Var p.u.
Q'1	0	+/- 1 nameplate Var p.u.
Q'2	0	+/- 1 nameplate Var p.u.
Q'3	0.44	+/- 1 nameplate Var p.u.
Voltage Active Power mode ²	Disabled	
V1	1.06	1.05-1.09 V p.u.
P1	1	nameplate power p.u.
V2	1.1	1.06-1.10 V p.u.
P2	0	0-1 nameplate power p.u.
P'2	0	-1-0 nameplate load p.u.
OLRT	10	0.5-60 seconds
Frequency Droop mode	Disabled	
DBOF	0.036	0-1 Hz
DBUF	0.036	0-1 Hz
KOF	0.05	0.02-0.07
KUF	0.05	0.02-0.07
OLRT	5	0.2-10 seconds
Normal Ramp Rate ²	100	1-100%/ seconds

¹Load parameters P' and Q' apply to single phase energy storage inverters only.

²California rule 21 function.

Appendix E: Immunity standards

The information in this appendix complies with the IEEE 1547-2018 standard. The IEEE 1547-2018 standard, establishes criteria and requirements for interconnection of distributed energy resources (DER) with electric power systems (EPS) and associated interfaces.

Immunity standard

Test type	Test method	Test level
Radiated immunity	IEEE C37.90.2	20 V/m
EFT	IEEE C37.90.1, C62.45, C62.41.2	+3 kV
		+4 kV
Surge	IEEE C62.45, C62.41.2, UL 1741	+3 kV
		+6 kV
Oscillatory test	IEEE C37.90.1	2.5 kV

Appendix F: Mechanical specifications

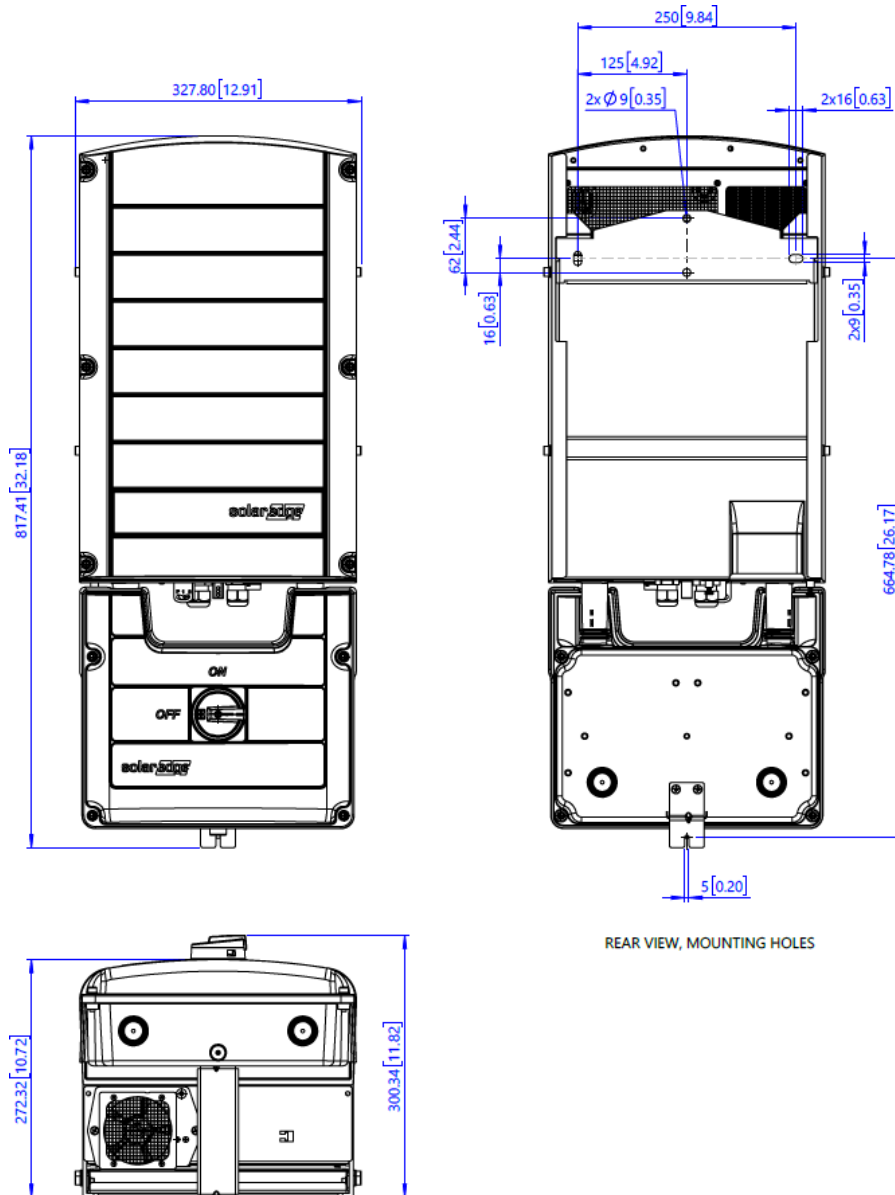

Figure 36: Dimensions of the Three Phase Inverter with the Connection Unit

Dimensions of the inverter mounting bracket

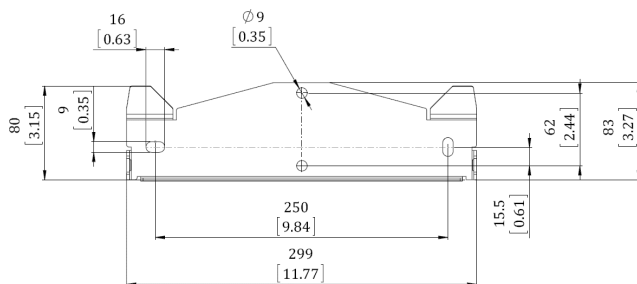

Figure 37: Dimensions of the inverter mounting bracket

Appendix G: PV hazard control models

Hazard control models

Power Optimizers	Inverters	DC Safety switches
P730	SE9kUS	DCD-3PH-US-S3-A
P750	SE10kUS	DCD-3PH-US-S3-B
P801	SE14.4kUS	DCD-3PH-US-S5-A-1
P850	SE16.7kUS	DCD-3PH-US-S5-A-3
P950	SE17.3kUS	DCD-3PH-US-S5-A-1P
P1101	SE20kUS	DCD-3PH-US-S7
S1201	SE24kUS	DCD-3PH-US-S8
C651U	SE30kUS	DCD-3PH-US-S9-DB
R800	SE33.3kUS	DCD-3PH-US-S9-DB-F
	SE40kUS	DCD-3PH-US-S9-DB-E
	SE43.2kUS	DCD-3PH-US-S9-DB-NF3
	SE50kUS	
	SE66.6kUS	
	SE80kUS	
	SE85kUS	
	SE100kUS	
	SE110kUS	
	SE120kUS	



NOTE

Power Optimizer models compliant with SolarEdge PV Hazard Control System: UL3741 are listed models as noted on the Power Optimizer datasheet.

Appendix H: Alternative power source

Energy-generation systems (such as PV inverters) connected to the grid may consist of different types of energy generating sources. In some cases, when grid power

is disconnected, PV inverters operate in parallel with other voltage sources, such as generators. When inverters operate concurrently with generators, they may be subjected to voltage and frequency fluctuations that exceed trips, which are preset according to regional grid connection requirements. To support simultaneous operation of the inverter and a generator, the inverter extends its Voltage and frequency operating range once it receives a Power Reduction Interface (PRI) signal indicating that grid power is unavailable (alternative Power Source mode”). When the grid power is restored, the inverter automatically reverts to its default country setting, which includes the original Voltage and frequency operating range.

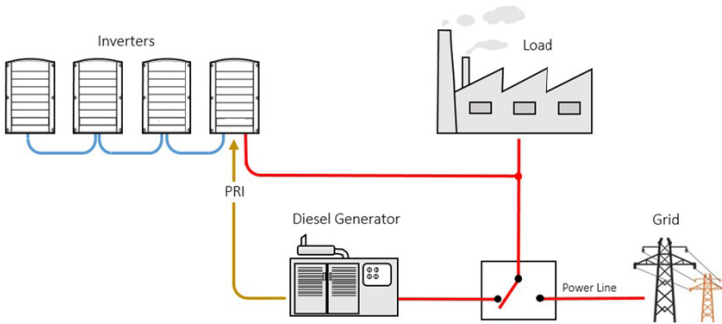

Figure 32: Alternative Power Source system

The Power reduction Interface (PRI) terminal block on the communication board (See Figure 34) is used signaling the inverter to switch to Alternative Power Source mode.

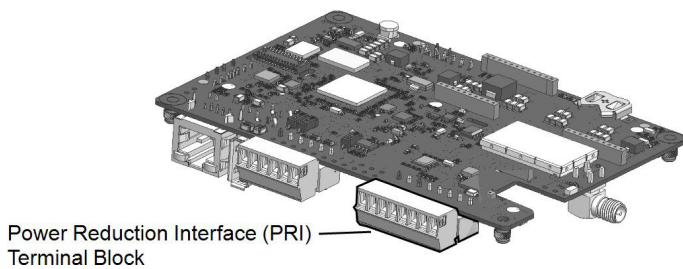

Figure 33: PRI terminal block location on the Communication Board of the inverter

For detailed connection and configuration of the inverter in alternative power source mode, see [Application Note - SolarEdge Inverter - Alternative Power Source](#).

Support contact information

If you have technical problems concerning SolarEdge products, contact us: <https://www.solaredge.com/us/support>.



Before contacting, make sure you have the following information available:

- Model and serial number of the product in question
- Error indicated on the SetApp mobile application, on the monitoring platform, or by the LEDs, if there is such an indication
- System configuration information, including the type and number of modules connected and the number and length of strings
- Communication method to the SolarEdge server if the site is connected
- Software version of the product as it appears in the status screen