

Solar Cooling

By  **ECOSOLARIS**

Solar Mini Split Hybrid ACDC Air Conditioner Heat Pump



IMPORTANT NOTE:

Read this manual carefully before installing or operating your solar air conditioner heat pump unit. Make sure to save this manual for future reference.

The design and specifications are subject to change without prior notice for product improvement.

VERSION: V2.02.02

MODELS: ECO-SPLIT-12K, ECO-SPLIT-18K, ECO-SPLIT-12K-TROP, ECO-SPLIT-18K-TROP



Table of Contents

Installation Manual

1- Safety Precautions

2- Accessories Supplied

**3- System Configuration
& Electrical Specifications**

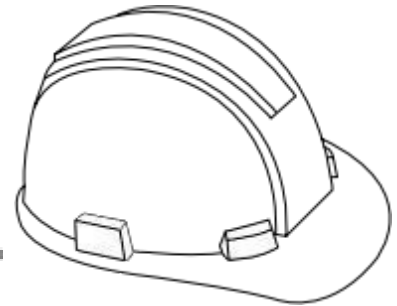

4- Indoor Unit Installation

5- Outdoor Unit Installation

6- Refrigerant Piping Connection

7- Air Evacuation

8- Electrical and Gas Leak Checks

**9- Installation of Solar Photovoltaic
System**



10- Test Run

11- Table of Revisions

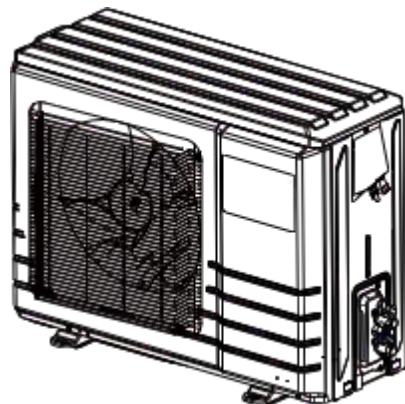

Safety Precautions

Read Safety Precautions Before Installation

Incorrect installation due to ignoring instructions can cause serious damage or injury.

The seriousness of potential damage or injuries is classified as either a WARNING or CAUTION.



WARNING

This symbol indicates that ignoring instructions may cause death or serious injury.

Disclaimer:

The heat pump must be installed by a qualified technician for the extended limited warranty to be activated. If you choose to install it yourself, you acknowledge that the warranty will not apply and that you assume full responsibility for any risks associated with installation and handling of components containing pressurized refrigerant, which can cause serious injury if mishandled. We strongly recommend hiring a certified professional for installation.



CAUTION

This symbol indicates that ignoring instructions may cause moderate injury to your person, or damage to your unit or other property.



This symbol indicates that you must never perform the action indicated.



WARNING

- ① **Use a dedicated circuit breaker.**
Improper or insufficient power supply can cause fire or electrical shock.
- ② When connecting refrigerant piping, **do not** let substances or gases other than the specified refrigerant enter the unit. The presence of other gases or substances will lower the unit's capacity, and can cause abnormally high pressure in the refrigeration cycle. This can cause explosion and injury.
- ③ **Do not** allow children to play with the air conditioner. Children must be supervised around the unit at all times.
 1. Installation must be performed by an authorized dealer or specialist. Defective installation can cause water leakage, electrical shock, or fire.
 2. Installation must be performed according to the installation instructions. Improper installation can cause water leakage, electrical shock, or fire.

(In North America, installation must be performed in accordance with the requirement of NEC and CEC by authorized personnel only.)

 3. Contact an authorized service technician for repair or maintenance of this unit.
 4. Only use the included accessories, parts, and specified parts for installation. Using non-standard parts can cause water leakage, electrical shock, fire, and can cause the unit to fail.
 5. Install the unit in a firm location that can support the unit's weight. If the chosen location cannot support the unit's weight, or the installation is not done properly, the unit may drop and cause serious injury and damage.

WARNING

6. For all electrical work, follow all local and national wiring standards, regulations, and the Installation Manual. You must use an independent circuit breaker to supply power. Do not connect other appliances. Insufficient electrical capacity or defects in electrical work can cause electrical shock or fire.

7. For all electrical work, use the specified cables. Connect cables tightly, and clamp them securely to prevent external forces from damaging the terminal. Improper electrical connections can overheat and cause fire, and may also cause shock.

8. All wiring must be properly arranged to ensure that the control board cover can close properly. If the control board cover is not closed properly, it can lead to corrosion and cause the connection points on the terminal to heat up, catch fire, or cause electrical shock.

9. In certain functional environments, such as kitchens, server rooms, etc., the use of specially designed air-conditioning units is highly recommended.

CAUTION

⊗ **Do not** install the unit in a location that may be exposed to combustible gas leaks. If combustible gas accumulates around the unit, it may cause fire.

⊗ **Do not** operate your air conditioner in a wet room such as a bathroom or laundry room. Too much exposure to water can cause electrical components to short circuit.

1. The product must be properly grounded at the time of installation and installed with earth leakage current breaker, or else electrical shock may occur.
2. Install drainage piping according to the instructions in this manual. Improper drainage may cause water damage to your home and property.



Note about Fluorinated Gasses

1. This air-conditioning unit contains fluorinated gasses. For specific information on the type of gas and the amount, please refer to the relevant label on the unit itself.
2. Installation, service, maintenance and repair of this unit must be performed by a certified technician.
3. Product uninstallation and recycling must be performed by a certified technician.
4. If the system has a leak-detection system installed, it must be checked for leaks at least every 12 months.
5. When the unit is checked for leaks, proper record-keeping of all checks is strongly recommended.

Accessories Supplied

2

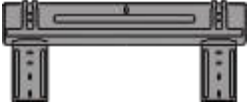
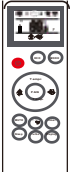
The solar heat pump comes with the following accessories. Use all of the installation parts and accessories to install the heat pump. Improper installation may result in water leakage, electrical shock and fire, or cause equipment failure, and could void de warranty.

Name	Shape	Quantity
Mounting plate		1
Remote Controller with 2x AAA batteries		1
Drain Pipe		1
Wrapping Tape		1

System Configuration & Electrical Specifications

3

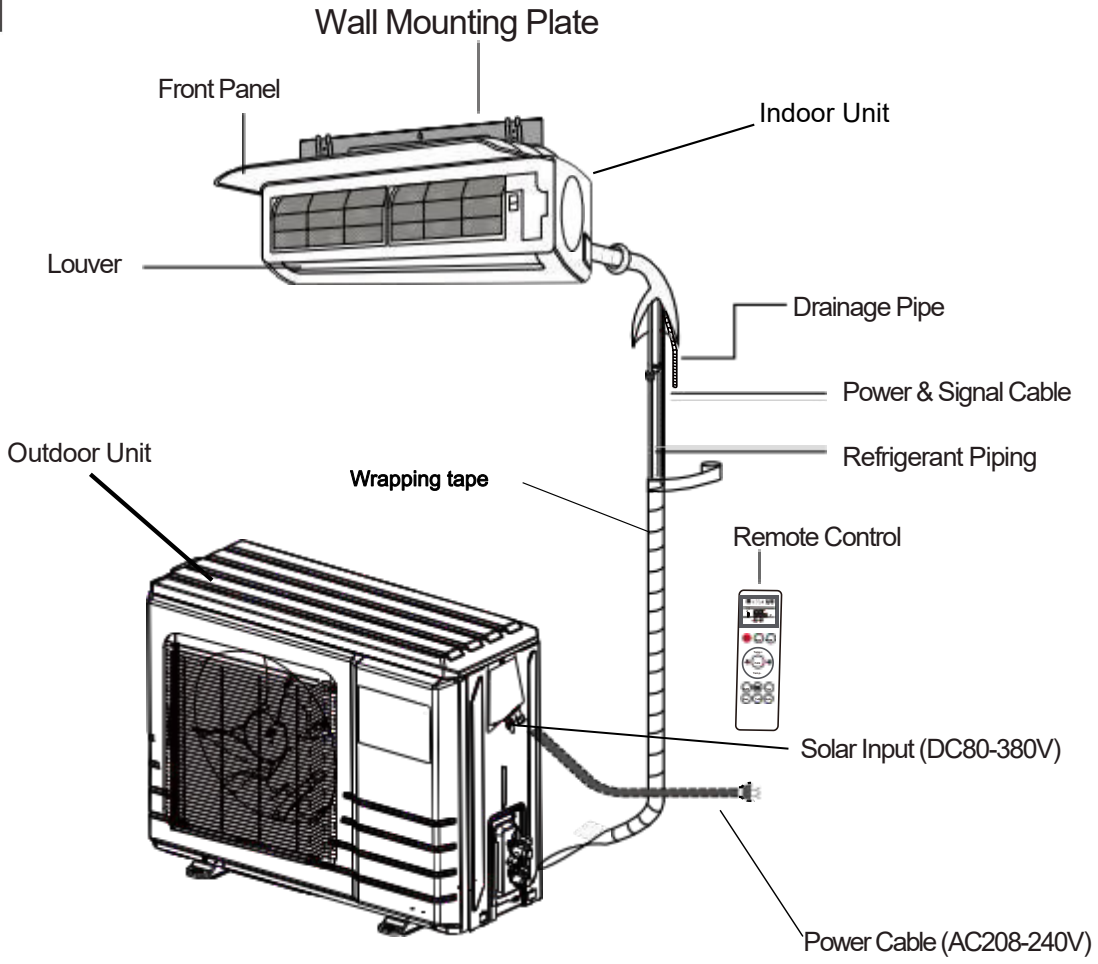

Fig. 3.1

NOTE ON ILLUSTRATIONS

Illustrations in this manual are for explanatory purposes. The actual shape of your units may be different. The actual shape shall prevail.

The main equipment consists of an indoor unit and an outdoor unit forming the heat pump system. Installation is the same as a standard mini-split heat pump system, with the addition of solar PV modules connected in series to supply the DC input. The system produce cooling or heating as required.

The heat pump system can be powered in several ways:

- **DC solar direct only (DC).** It will start and run on solar power only. During cloudy periods, the unit will still work, but its output will be reduced. It will not work at night.
- **Hybrid DC and AC grid 240V power (AC/DC).** The system will always prioritize DC solar power and will draw AC grid 240V power to compensate when needed. This would be applicable during cloudy periods and at night.
- **AC grid 240V power only (AC).** Flexibility to add solar panels later on if desired).
- **48V battery power (DC)***

****Please note that additional components are required when powering the unit by battery, and that PV recommendations differ from those used in Hybrid AC/DC or solar-only modes. These alternate configurations are not covered in this manual.***

Electrical Input Requirements & Recommended Solar Parameters		
Model	12,000 BTU	18,000 BTU
Power AC	208V-230V (50Hz) 240V (60Hz)	208V-230V (50Hz) 240V (60Hz)
Power Input DC	80-380 VDC	80-380 VDC
Max PV Voltage AC/DC Mode	380 VOC	380 VOC
Max PV Voltage DC Only Mode	350 VOC	350 VOC
Max PV DC Input Current	DC 15 A	DC 15 A
Recommended solar array size ACDC / Hybrid mode	900-1200 W	1300-1600 W
Recommended solar array size DC-only / Solar-Only mode	1200-1400 W	1600-1800W

Recommendations

- Calculate the required number of solar panels based on the maximum DC power input.
- Ensure the total DC voltage (VOC) stays within the allowable range.
- Always connect PV modules in series.
- The number of panels depends on the type of panels used and their wattage

Product Specifications

MODEL	12,000 BTU	18,000 BTU
COOLING PERFORMANCE		
SEER2	23.40 Btu/W	21.70 Btu/W
EER	13.74 Btu/W	12.79 Btu/W
Cooling Capacity	3500 W (12,000 Btu/h)	5150 W (18,000 Btu/h)
HEATING PERFORMANCE		
HSPF2	9.70 Btu/W	9.55 Btu/W
COP (Btu/W)	13.34 Btu/W	13.70 Btu/W
COP(W/W)	3.90 W/W	4.01 W/W
Heating Capacity	3500 W (12,000 Btu/h)	5150 W (18,000 Btu/h)
ELECTRICAL (AC)		
Rated Voltage	208-240 V	
Min/Max Voltage	150-265 V	
Rated Current Cooling	3.85 A	5.88 A
Rated Current Heating	4.02 A	5.80 A
Rated Power Cooling	180-860 W	220-1340 W
Rated Power Heating	180-905 W	220-1320 W
Rated Frequency	50-60 Hz	
Circuit Breaker	15 A	
ELECTRICAL (DC)		
Rated Voltage (DC Solar-Only Mode)	80-350 VDC	
Rated Voltage (AC/DC Hybrid Mode)	80-380 VDC	
Maximum Input PV Voltage	380 VOC	
Maximum Input PV Amperage	15 A	
Recommended PV Wattage	900 - 1400 W	1300 - 1800 W
48V Battery Bank Minimum Capacity (if applicable)	5 kWh or more	
REFRIGERANT		
Refrigerant Type	R32 (830 g/29.3 oz)	R32 (950 g/33.5 oz)
Maximum Allowable Pressure	4.3 MPa (~624 psi)	
Liquid Valve Diameter	6.35 mm (1/4")	
Gas Valve Diameter	9.5 mm (3/8")	
Max Refrigerant Lineset Length	15 m (49.2 ft)	20 m (65.6 ft)
Max Refrigerant Lineset Drop Height	5 m (16.4 ft)	10 m (32.8 ft)

Product Specifications (Continued)

MODEL	12,000 BTU	18,000 BTU
COMPRESSOR		
Compressor Type	Rotary	
Compressor Trademark	HIGHLY	
Input Power	830 W	900 W
INDOOR UNIT		
Fan Type	Cross-flow	
Fan Speed (High, Medium, Low, Auto)	1300/1200/1100/960 rpm	1050/950/850/750 rpm
Air Flow (High, Medium, Low, Auto)	540/485/435/350 m ³ /h (318/285/256/206 CFM)	980/880/740/620 m ³ /h (577/518/436/365 CFM)
Sound Pressure (Low, Medium, High)	24-37-42 dB(A)	30-42-45 dB(A)
Operating Temperature Range	16 - 32 °C (60 - 90 °F)	
Unit Dimensions (W x D x H)	895 x 210 x 298 mm (35.2 x 8.3 x 11.7in)	1000 x 236 x 306 mm (39.4 x 9.3 x 12.0in)
Packaging Dimension	965 x 275 x 370 mm (38.0 x 10.8x14.6in)	1075 x 310 x 385 mm (42.3 x 12.2x 15.2in)
Net Weight	11kg (24.3 lbs)	13kg (28.7 lbs)
OUTDOOR UNIT		
Sound Pressure	52 dB(A)	54 dB(A)
Operating Temperature Range (Cooling)	0 - 55 °C (32 - 131°F)	
Operating Temperature Range (Heating)	-15- 32 °C (5- 90 °F)	
Unit Dimensions (W x D x H)	782 x 336 x 544 mm (30.8 x 13.2x 21.4in)	856 x 365 x 555 mm (33.7x 14.4x 21.9in)
Packaging Dimension (W x D x H)	855 x 367 x 600 mm (33.7x 14.4x 23.6 in)	913x 396 x 604 mm (35.9 x 15.6x 23.8 in)
Net Weight	27 kg (59.5 lbs)	31kg (68.3 lbs)

Indoor Unit Installation

Installation Summary

4

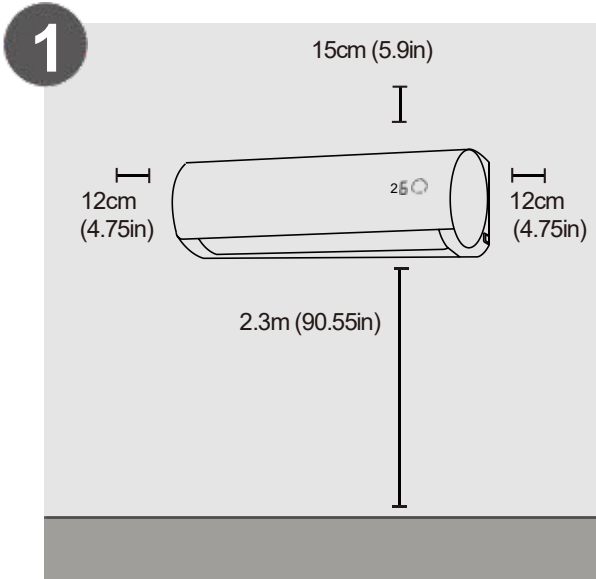

Select Installation Location

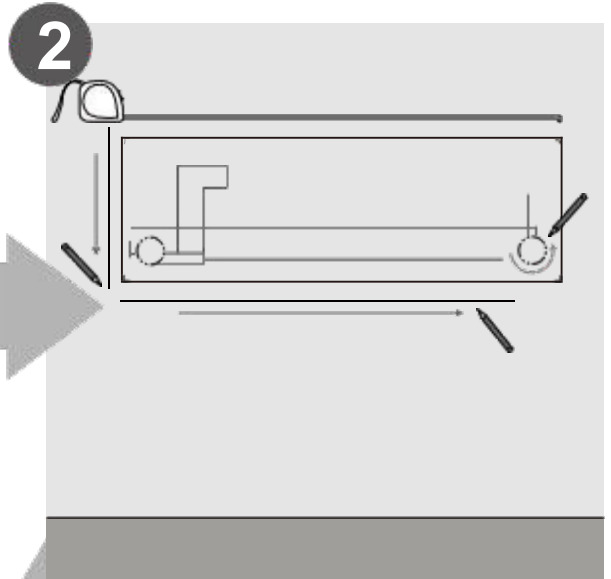

Determine Wall Hole Position

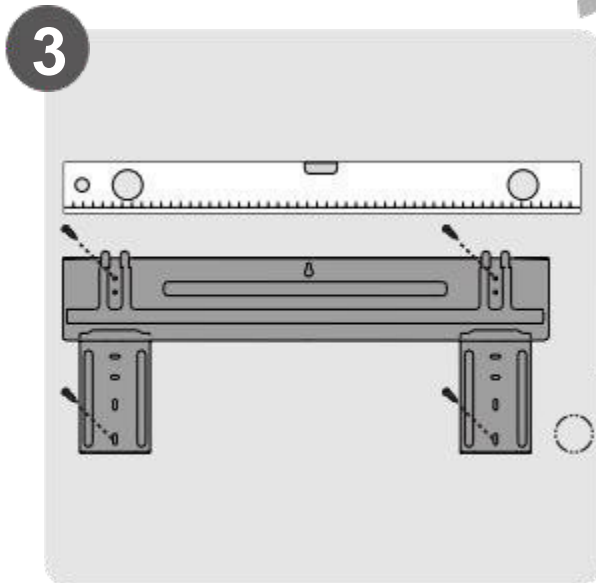

Attach Mounting Plate

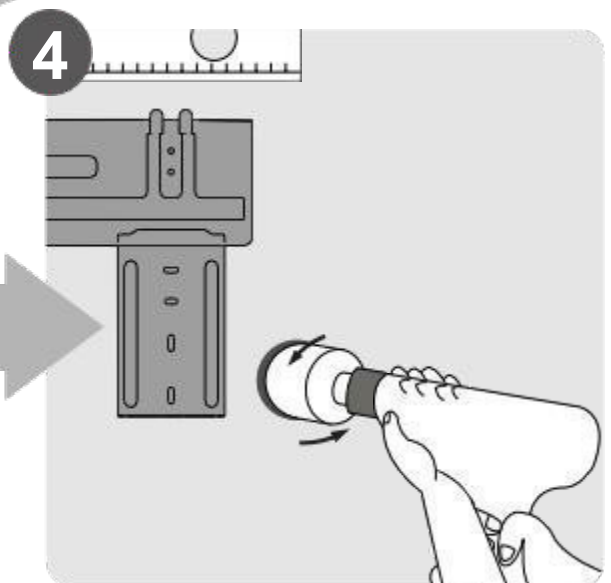

Drill Wall Hole

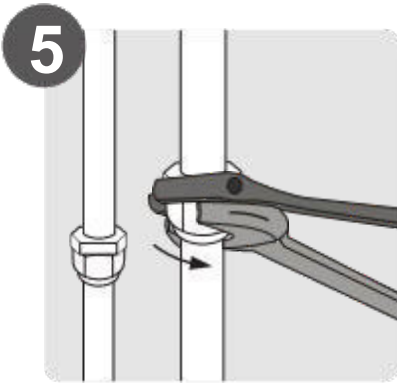

Connect Piping

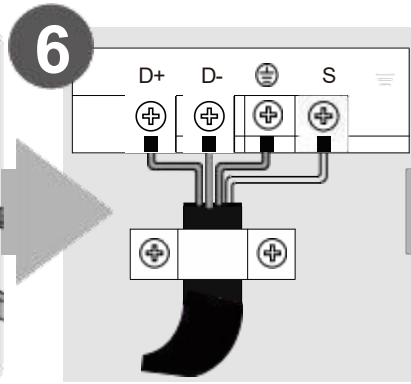

Connect Wiring

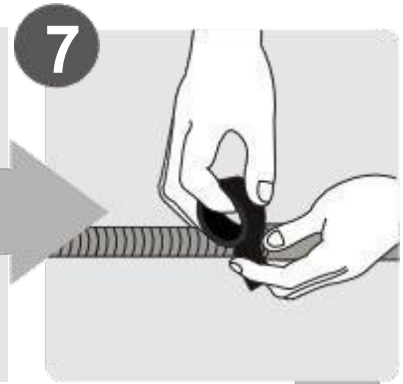

Prepare Drain Hose

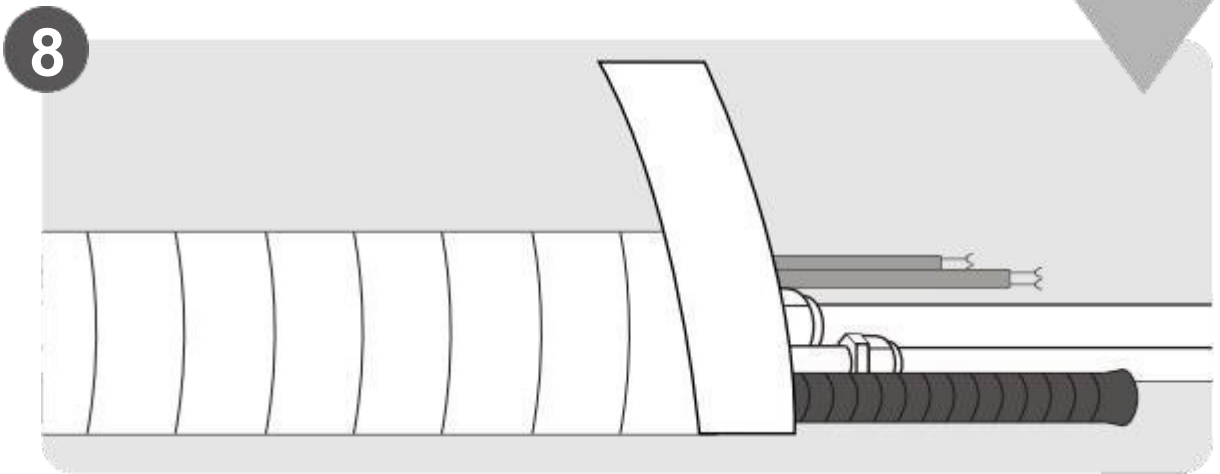

Wrap Piping and Cable



Mount Indoor Unit

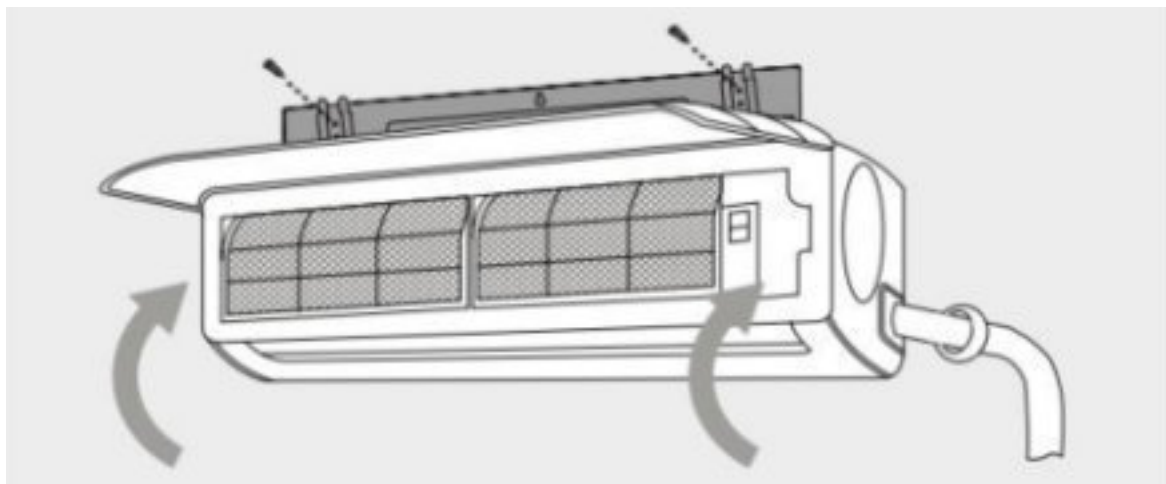

Installation Instructions – Indoor Unit

PRIOR TO INSTALLATION

Before installing the indoor unit, refer to the label on the product box to make sure that the model number of the indoor unit matches the model number of the outdoor unit.

Step 1: Select installation location

Before installing the indoor unit, you must choose an appropriate location. The following standards will help you choose an appropriate location for the unit.

Proper installation locations meet the following standards:

- Good air circulation
- Convenient drainage
- Noise from the unit will not disturb other people
- Firm and solid—the location will not vibrate
- Strong enough to support the weight of the unit
- A location at least one meter from all other electrical devices (e.g., TV, radio, computer)

DO NOT install unit in the following locations:

- ⊘ Near any source of heat, steam, or combustible gas
- ⊘ Near flammable items such as curtains or clothing
- ⊘ Near any obstacle that might block air circulation
- ⊘ Near the doorway
- ⊘ In a location subject to direct sunlight

NOTE ABOUT WALL HOLE:

If there is no fixed refrigerant piping:

While choosing a location, be aware that you should leave ample room for a wall hole (see **Drill wall hole for connective piping step**) for the signal cable and refrigerant piping that connect the indoor and outdoor units. The default position for all piping is the right side of the indoor unit (while facing the unit). However, the unit can accommodate piping to both the left and right.

Refer to the following diagram to ensure proper distance from walls and ceiling:

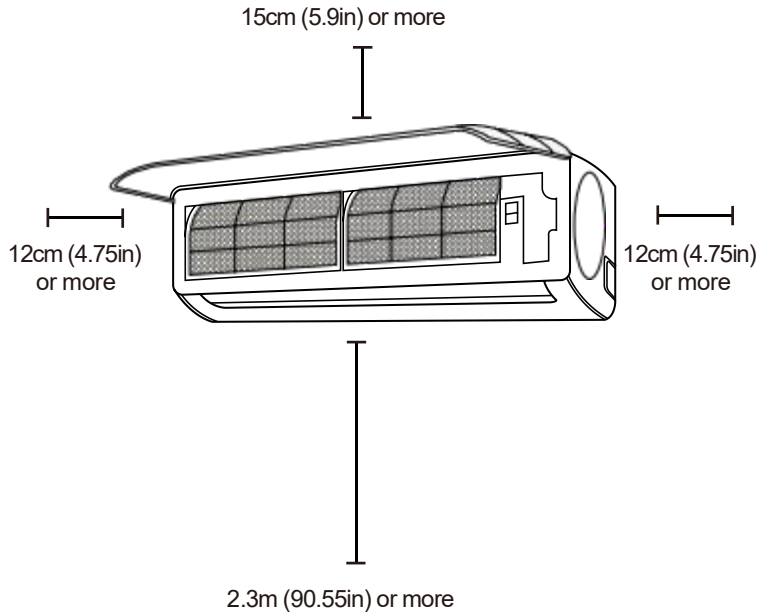

Fig. 4.1

Step 2: Attach mounting plate to wall

The mounting plate is the device on which you will mount the indoor unit.

1. Remove the screw that attaches the mounting plate to the back of the indoor unit.
2. Place the mounting plate against the wall in a location that meets the standards in the Select Installation Location step. (See Mounting Plate Dimensions for detailed information on mounting plate sizes.)
3. Drill holes for mounting screws in places that:
 - can support at least four times the weight of the unit, either by using anchors or by screwing directly into the studs.
 - correspond to screw holes in the mounting plate
4. Secure the mounting plate to the wall with the screws provided.
5. Make sure that mounting plate is flat against the wall.

NOTE FOR CONCRETE OR BRICK WALLS:

If the wall is made of brick, concrete, or a similar material, drill holes corresponding to the anchor size, insert the sleeve anchors, or use an alternative anchoring method of your choice to secure the mounting plate to the wall.

Step 3: Drill wall hole for connective piping

You must drill a hole in the wall for refrigerant piping, the drainage pipe, power cable and the signal cable that will connect the indoor and outdoor units.

1. Determine the location of the wall hole based on the position of the mounting plate. Refer to **Mounting Plate Dimensions** on the next page to help you determine the optimal position. The wall hole should have a 65mm (2.5in) diameter at least, and at a slightly lower angle to facilitate drainage.
2. Using a 65-mm (2.5in) core drill, drill a hole in the wall. Make sure that the hole is drilled at a slight downward angle, so that the outdoor end of the hole is lower than the indoor end by about 5mm to 7mm (0.2-0.275in). This will ensure proper water drainage. (See **Fig. 4.2**)
3. Place the protective wall cuff in the hole. This protects the edges of the hole and will help seal it when you finish the installation process.

! CAUTION

When drilling the wall hole, make sure to avoid wires, plumbing, and other sensitive components.

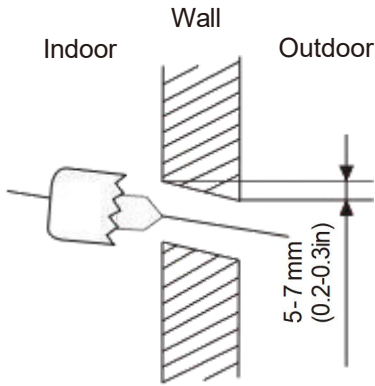
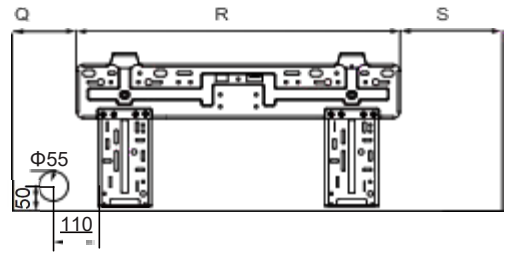

Fig. 4.2

MOUNTING PLATE DIMENSIONS

Different models have different mounting plates. In order to ensure that you have ample room to mount the indoor unit, the diagrams to the right show different types of mounting plates along with the following dimensions:

- Width of mounting plate
- Height of mounting plate
- Width of indoor unit relative to plate
- Height of indoor unit relative to plate
- Recommended position of wall hole (both to the left and right of mounting plate)
- Relative distances between screw holes



12,000BTU ≤

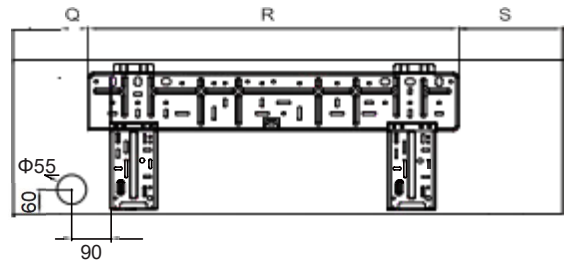

18,000BTU ≥

Indoor Unit
Installation

Correct Orientation of Mounting Plate



Step 4: Prepare refrigerant piping

The refrigerant piping is inside an insulating sleeve attached to the back of the unit. You must prepare the piping before passing it through the hole in the wall. Refer to the **Refrigerant Piping Connection** section of this manual for detailed instructions on pipe flaring and flare torque requirements, technique, etc.

1. Based on the position of the wall hole relative to the mounting plate, choose the side from which the piping will exit the unit.
2. If the wall hole is behind the unit, keep the knock-out panel in place. If the wall hole is to the side of the indoor unit, remove the plastic knock-out panel from that side of the unit. (See **Fig. 4.3**). This will create a slot through which your piping can exit the unit. Use needle nose pliers if the plastic panel is too difficult to remove by hand.
3. If existing connective piping is already embedded in the wall, proceed directly to the **Connect Drain Hose** step. If there is no embedded piping, connect the indoor unit's refrigerant piping to the connective piping that will join the indoor and outdoor units. Refer to the **Refrigerant Piping Connection** section of this manual for detailed instructions.
4. Based on the position of the wall hole relative to the mounting plate, determine the necessary angle of your piping.
5. Grip the refrigerant piping at the base of the bend.
6. Slowly, with even pressure, bend the piping towards the hole. **Do not** dent or damage the piping during the process.

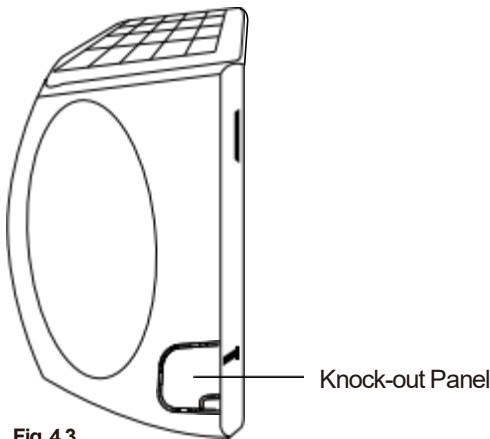

Fig. 4.3

NOTE ON PIPING ANGLE

Refrigerant piping can exit the indoor unit from four different angles:

- Left-hand side
- Left rear
- Right-hand side
- Right rear

Refer to **Fig. 4.4** for details.

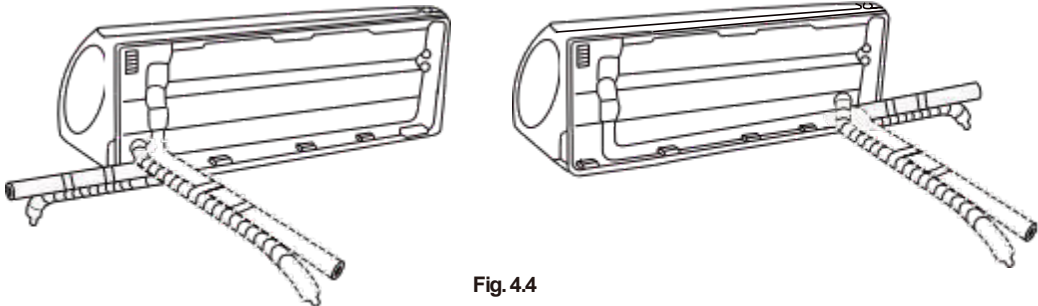

Fig. 4.4

! CAUTION

Be extremely careful not to dent or damage the piping while bending them away from the unit. Any dents in the piping will affect the unit's performance.

Step 5: Connect drain hose

By default, the drain hose is attached to the left-hand side of unit (when you're facing the back of the unit). However, it can also be attached to the right-hand side.

- To ensure proper drainage, attach the drain hose on the same side that your refrigerant piping exits the unit.
- Attach drain hose extension (purchased separately) to the end of drain hose.
- For the portion of the drain hose that will remain indoors, wrap it with insulating tape to prevent condensation.
- Remove the air filter and pour a small amount of water into the drain pan to make sure that water flows from the unit smoothly.

NOTE ON DRAIN HOSE PLACEMENT

Make sure to arrange the drain hose according to **Fig. 4.5** .

- ⊘ **DO NOT** kink the drain hose.
- ⊘ **DO NOT** create a water trap.
- ⊘ **DO NOT** put the end of drain hose in water or a container that will collect water.

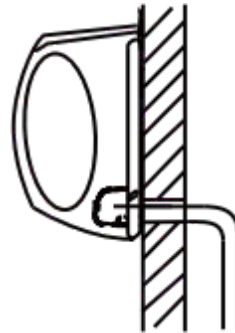

Fig. 4.5

✓ **CORRECT**

Make sure there are no kinks or dentin drain hose to ensure proper drainage.

⊘ **NOT CORRECT**

Kinks in the drain hose will create water traps.

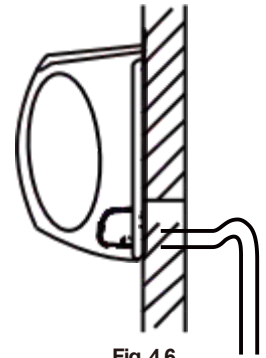

Fig. 4.6

⊘ **NOT CORRECT**

Kinks in the drain hose will create water traps.

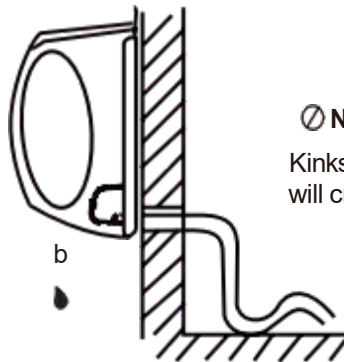

Fig. 4.7

⊘ **NOT CORRECT**

Do not place the end of the drain hose in water or in containers that collect water. This will prevent proper drainage.

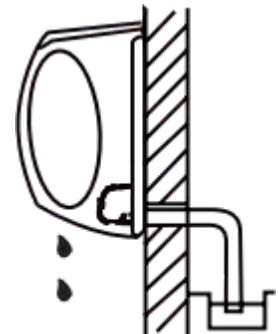

Fig. 4.8

**BEFORE PERFORMING ELECTRICAL WORK, READ THESE REGULATIONS**

1. All wiring must comply with local and national electrical codes, and must be installed by a licensed electrician.
2. All electrical connections must be made according to the Electrical Connection Diagram located on the panels of the indoor and outdoor units.
3. If a serious safety issue is found with the electrical system, the installation will be paused. The situation will be explained clearly, and work will not continue until the issue is properly resolved to ensure safety.
4. Make sure the power supply is sufficient and always stays within the rated voltage range. An inadequate power supply can cause malfunction, electrical shock, or fire.
5. If connected to AC grid power, install a surge protector and a main power switch (disconnect switch) with a capacity of 1.5 times the unit's maximum current.
6. If connecting power to fixed wiring, a switch or circuit breaker that disconnects all poles and has a contact separation of at least 1/8in (3mm) must be incorporated in the fixed wiring. The qualified technician must use an approved circuit breaker.
7. Only connect the unit to an dedicated circuit breaker. Do not connect another appliance to that circuit breaker.
8. Make sure to properly ground the air conditioner in accordance with local electrical codes and regulations.
9. Every wire must be firmly connected. Loose wiring can cause the terminal to overheat, resulting in product malfunction and possible fire.
10. Do not let wires touch or rest against refrigerant tubing, the compressor, or any moving parts within the unit.
11. If the unit has an auxiliary electric heater, it must be installed at least 1 meter (40in) away from any combustible materials.

**WARNING**

BEFORE PERFORMING ANY ELECTRICAL OR WIRING WORK, TURN OFF THE MAIN POWER TO THE SYSTEM.

Step 6: Connect signal cable

The signal cable enables communication between the indoor and outdoor units. You must first choose the right cable size before preparing it for connection.

Cable Types

- **Indoor Power Cable** (if applicable): H05VV-F or H05V2V2-F
- **Outdoor Power Cable:** H07RN-F
- **Signal Cable:** H07RN-F

Minimum Cross-Sectional Area of Power and Signal Cables

North America

Appliance Amps (A)	AWG	mm ²
10	18	1.0
13	16	1.2
18	14	2.0
25	12	3.0
30	10	5.0

Other Regions

Rated Current of Appliance (A)	Nominal Cross-Sectional Area (mm ²)
> 3 and ≤ 6	0.75
> 6 and ≤ 10	1
> 10 and ≤ 16	1.5
> 16 and ≤ 25	2.5
> 25 and ≤ 32	4
> 32 and ≤ 40	6

CHOOSE THE RIGHT CABLE SIZE

The size of the power supply cable, signal cable, fuse, and switch needed is determined by the maximum current of the unit. The maximum current is indicated on the nameplate located on the side panel of the unit. Refer to this nameplate to choose the right cable, fuse, or switch.

TAKE NOTE OF FUSE SPECIFICATIONS

The air conditioner's circuit board (PCB) is designed with a fuse to provide overcurrent protection. The specifications of the fuse are printed on the circuit board, such as: 20A/250VAC

1. Prepare the cable for connection:
 - a. Using wire strippers, strip the rubber jacket from both ends of signal cable to reveal about 15cm (6in) of the wires inside.
 - b. Strip the insulation from the ends of the wires.
 - c. Using wire crimper, crimp u-type lugs on the ends of the wires.

PAY ATTENTION TO LIVE WIRE

While crimping wires, make sure you clearly distinguish the Live ("L") Wire from other wires.

2. Open front panel of the indoor unit.
3. Using a screwdriver, open the wire box cover on the right side of the unit. This will reveal the terminal block.

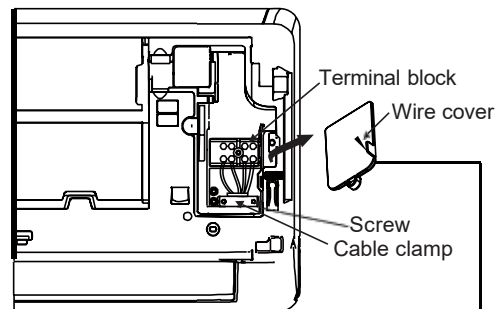

Fig. 4.9

The Wiring Diagram is located on the inside of the indoor unit's wire cover.

WARNING

ALL WIRING MUST BE PERFORMED STRICTLY IN ACCORDANCE WITH THE WIRING DIAGRAM LOCATED ON THE INSIDE OF THE INDOOR UNITS' WIRE COVER.

4. Unscrew the cable clamp below the terminal block and place it to the side.
5. Facing the back of the unit, remove the plastic panel on the bottom left-hand side.

6. Feed the signal wire through this slot, from the back of the unit to the front.
7. Facing the front of the unit, match the wire colors with the labels on the terminal block, connect the u-lug and firmly screw each wire to its corresponding terminal.

CAUTION

DO NOT MIX UP D+, D- AND S WIRES

This is dangerous, and can cause the air conditioning unit to malfunction.

8. After checking to make sure every connection is secure, use the cable clamp to fasten the signal cable to the unit. Screw the cable clamp down tightly.
9. Replace the wire cover on the front of the unit, and the plastic panel on the back.

NOTE ABOUT WIRING

THE WIRING CONNECTION PROCESS MAY DIFFER SLIGHTLY BETWEEN UNITS.

Step 7: Wrap piping and cables

Before passing the piping, drain hose, and the signal cable through the wall hole, you must bundle them together to save space, protect them, and insulate them.

1. Bundle the drain hose, refrigerant pipes, and signal cable according to **Fig. 4.12** .

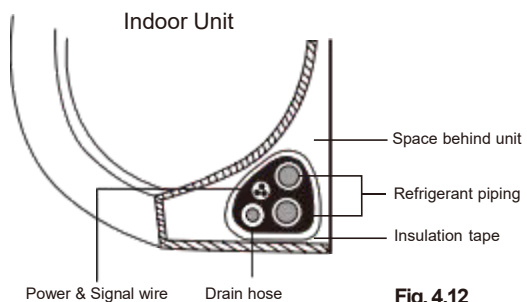

Fig. 4.12

DRAIN HOSE MUST BE ON BOTTOM

Make sure that the drain hose is at the bottom of the bundle. Putting the drain hose at the top of the bundle can cause the drain pan to overflow, which can lead to fire or water damage.

DO NOT INTERTWINE SIGNAL CABLE WITH OTHER WIRES

While bundling these items together, do not intertwine or cross the signal cable with any other wiring.

2. Using adhesive vinyl tape, attach the drain hose to the underside of the refrigerant pipes.
3. Using insulation tape, wrap the signal wire, refrigerant pipes, and drain hose tightly together. Double-check that all items are bundled in accordance with **Fig. 4.12** .

DO NOT WRAP ENDS OF PIPING

When wrapping the bundle, keep the ends of the piping unwrapped. You need to access them to test for leaks at the end of the installation process (refer to **Electrical Checks and Leak Checks** section of this manual).

Step 8: Mount indoor unit

If you installed new connective piping to the outdoor unit, do the following:

1. If you have already passed the refrigerant piping through the hole in the wall, proceed to Step 4.
2. Otherwise, double-check that the ends of the refrigerant pipes are sealed to prevent dirt or foreign materials from entering the pipes.
3. Slowly pass the wrapped bundle of refrigerant pipes, drain hose, and signal wire through the hole in the wall.
4. Hook the top of the indoor unit on the upper hook of the mounting plate.
5. Check that unit is hooked firmly on mounting by applying slight pressure to the left and right-hand sides of the unit. The unit should not jiggle or shift.
6. Using even pressure, push down on the bottom half of the unit. Keep pushing down until the unit snaps onto the hooks along the bottom of the mounting plate.
7. Again, check that the unit is firmly mounted by applying slight pressure to the left and the right-hand sides of the unit.

If refrigerant piping is already embedded in the wall, do the following:

1. Hook the top of the indoor unit on the upper hook of the mounting plate.
2. Use a bracket or wedge to prop up the unit, giving you enough room to connect the refrigerant piping, signal cable, and drain hose. Refer to **Fig. 4.13** for an example.

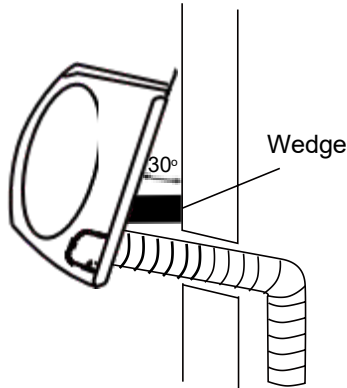
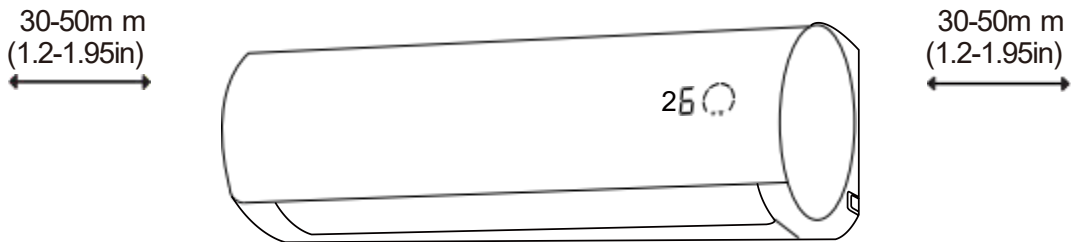

Fig. 4.13

3. Connect drain hose and refrigerant piping (refer to **Refrigerant Piping Connection** section of this manual for instructions).
4. Keep pipe connection point exposed to perform the leak test (refer to **Electrical Checks and Leak Checks** section of this manual).
5. After the leak test, wrap the connection point with insulation tape.
6. Remove the bracket or wedge that is propping up the unit.
7. Using even pressure, push down on the bottom half of the unit. Keep pushing down until the unit snaps onto the hooks along the bottom of the mounting plate.

UNIT IS ADJUSTABLE

Keep in mind that the hooks on the mounting plate are smaller than the holes on the back of the unit. If you find that you don't have ample room to connect embedded pipes to the indoor unit, the unit can be adjusted left or right by about 30-50mm (1.25-1.95in), depending on the model. (See **Fig. 4.14** .)



Move to left or right

Fig. 4.14

Outdoor Unit Installation

5

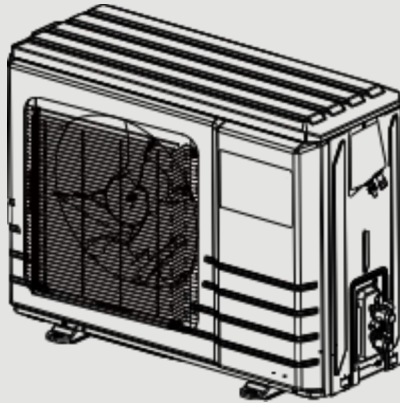

Installation Instructions – Outdoor Unit

Step 1: Select installation location

Before installing the outdoor unit, you must choose an appropriate location. The following are standards that will help you choose an appropriate location for the unit.

Proper installation locations meet the following standards:

- ✓ Meets all spatial requirements shown in Installation Space Requirements (Fig. 5.1)
- ✓ Good air circulation and ventilation
- ✓ Firm and solid—the location can support the unit and will not vibrate
- ✓ Noise from the unit will not disturb others
- ✓ Protected from prolonged periods of direct sunlight or rain

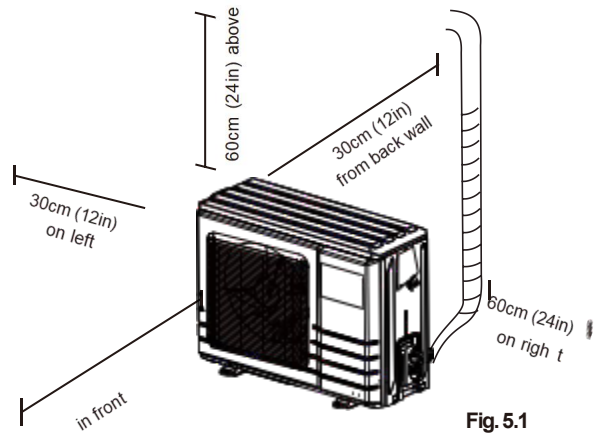

Fig. 5.1

DO NOT install unit in the following locations:

- ⊘ Near an obstacle that will block air inlets and outlets
- ⊘ Near a public street, crowded areas, or where noise from the unit will disturb others
- ⊘ Near animals or plants that will be harmed by hot air discharge
- ⊘ Near any source of combustible gas
- ⊘ In a location that is exposed to large amounts of dust
- ⊘ In a location exposed to an excessive amount of salty air, unless permitted by your unit's specifications.

SPECIAL CONSIDERATIONS FOR EXTREME WEATHER

If the unit is exposed to heavy wind:

Install unit so that air outlet fan is at a 90° angle to the direction of the wind. If needed, build a barrier in front of the unit to protect it from extremely heavy winds.

See **Fig. 5.2** and **Fig. 5.3** below.

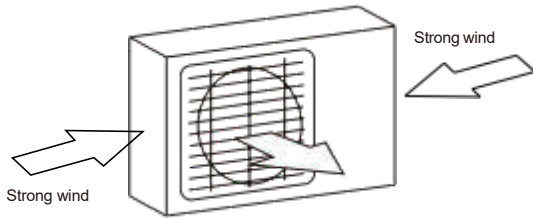

Fig. 5.2

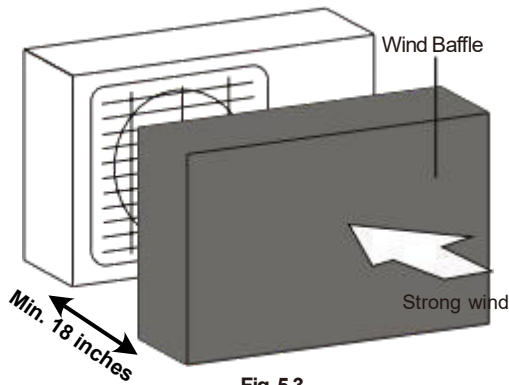

Fig. 5.3

If the unit is frequently exposed to heavy rain or snow:

Build a shelter above the unit to protect it from the rain or snow. Be careful not to obstruct air flow around the unit. **If the unit is frequently exposed to salty air (seaside):** Use outdoor unit that is specially designed to resist corrosion.

Step 2 : Anchor outdoor unit

The outdoor unit can be anchored to the ground or to a wall-mounted bracket.

UNIT MOUNTING DIMENSIONS

The following is the outdoor unit sizes and the distance between the mounting feet. Prepare the installation base of the unit according to the dimensions below.

Capacity	L	H	W
12,000 BTU	31 3/8" (79.7cm)	21 7/8" (55.6cm)	13 1/4" (33.6cm)
18,000 BTU	34 3/8" (87.4cm)	22" (55.9cm)	13 7/8" (35.3cm)

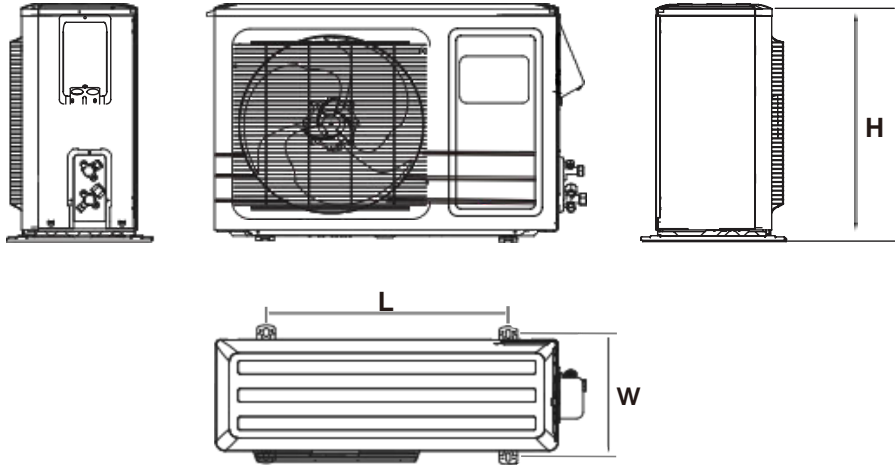

Fig. 5.5

If you will install the unit on the ground or on a concrete mounting platform, do the following:

1. Mark the positions for four expansion bolts based on dimensions in the Unit Mounting Dimensions chart.
2. Pre-drill holes for expansion bolts.
3. Clean concrete dust away from holes.
4. Place a nut on the end of each expansion bolt.
5. Hammer expansion bolts into the pre-drilled holes.
6. Remove the nuts from expansion bolts, and place outdoor unit on bolts.
7. Put washer on each expansion bolt, then replace the nuts.

8. Using a wrench, tighten each nut until snug.

WARNING

WHEN DRILLING INTO CONCRETE, EYE PROTECTION IS RECOMMENDED AT ALL TIMES.

If you will install the unit on a wall-mounted bracket, do the following:

CAUTION

Before installing a wall-mounted unit, make sure that the wall is made of solid brick, concrete, or of similarly strong material. **The wall must be able to support at least four times the weight of the unit.**

1. Mark the position of bracket holes based on dimensions in the Unit Mounting Dimensions chart.
2. Pre-drill the holes for the expansion bolts.
3. Clean dust and debris away from holes.
4. Place a washer and nut on the end of each expansion bolt.
5. Thread expansion bolts through holes in mounting brackets, put mounting brackets in position, and hammer expansion bolts into the wall.
6. Check that the mounting brackets are level.
7. Carefully lift unit and place its mounting feet on brackets.
8. Bolt the unit firmly to the brackets.

TO REDUCE VIBRATIONS OF WALL-MOUNTED UNIT

You can install the wall-mounted unit with rubber gaskets to reduce vibrations and noise.

Step 3 : Connect signal and power cables

The outside unit's terminal block is protected by an electrical wiring cover on the side of the unit. A comprehensive wiring diagram is printed on the inside of the wiring cover.

BEFORE PERFORMING ELECTRICAL WORK, READ THESE REGULATIONS

- All wiring must comply with local and national electrical codes, and must be installed by a licensed electrician.
- All electrical connections must be made according to the Electrical Connection Diagram located on the side panels of the indoor and outdoor units.
- If there is a serious safety issue with the power supply, stop work immediately. Explain your reasoning to the client, and refuse to install the unit until the safety issue is properly resolved.
- Make sure the power supply is sufficient and always stays within the rated voltage range. An inadequate power supply can cause malfunction, electrical shock, or fire.
- If connecting power to fixed wiring, install a surge protector and main power switch with a capacity of 1.5 times the maximum current of the unit.
- If connecting power to fixed wiring, a switch or circuit breaker that disconnects all poles and has a contact separation of at least 1/8in (3mm) must be incorporated in the fixed wiring. The qualified technician must use an approved circuit breaker or switch.
- Only connect the unit to an individual branch circuit outlet. Do not connect another appliance to that outlet.
- Make sure to properly ground the air conditioner.
- Every wire must be firmly connected. Loose wiring can cause the terminal to overheat, resulting in product malfunction and possible fire.
- **Do not** let wires touch or rest against refrigerant tubing, the compressor, or any moving parts within the unit.
- If the unit has an auxiliary electric heater, it must be installed at least 1 meter (40in) away from any combustible materials.



WARNING

BEFORE PERFORMING ANY ELECTRICAL OR WIRING WORK, TURN OFF ALL SOURCE OF POWER.

1. Prepare the cable for connection:

USE THE RIGHT CABLE

- Outdoor Power Cable: H07RN-F
- Signal Cable: H07RN-F

Minimum Cross-Sectional Area of Power and Signal Cables

North America

Appliance Amps (A)	AWG	²
10	18	1.0
13	16	1.2
18	14	2.0
25	12	3.0
30	10	5.0

Other Regions

Rated Current of Appliance (A)	Nominal Cross-Sectional Area (mm ²)
> 3 and ≤ 6	0.75
> 6 and ≤ 10	1
> 10 and ≤ 16	1.5
> 16 and ≤ 25	2.5
> 25 and ≤ 32	4
> 32 and ≤ 40	6

Ensure the wire is properly stripped, firmly secured, and positioned to maintain a stable electrical connection.

PAY ATTENTION TO LIVE WIRE

While crimping wires, make sure you clearly distinguish the Live ("L") Wire from other wires.



WARNING

ALL WIRING MUST PERFORMED STRICTLY IN ACCORDANCE WITH THE WIRING DIRGRAM LOCATED INSIDE THE OUTDOOR UNIT'S WIRE COVER.

2. Unscrew the electrical wiring cover and remove it.
3. Unscrew the cable clamp below the terminal block and place it to the side.
4. Match the wire colors/labels with the labels on the terminal block, and firmly screw the u-lug of each wire to its corresponding terminal.
5. After checking to make sure every connection is secure, loop the wires around to prevent rainwater from flowing into the terminal.
6. Using the cable clamp, and fasten the cable to the unit. Screw the cable clampdown tightly.
7. Before connect the solar array to the air conditioner, make sure solar array voltage is between 80~380V DC and do not reverse solar array positive and negative output to air conditioner.

The diagrams below show the two possible configurations for connecting the outdoor unit. Depending on your heat pump's version, the wiring may vary.

Please compare your unit with the illustrations to select the matching diagram.

Diagram 1

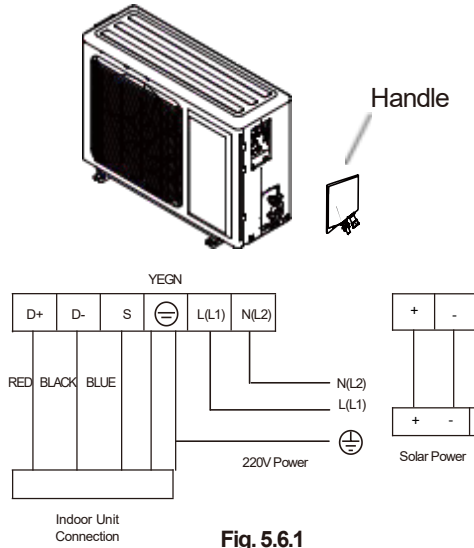
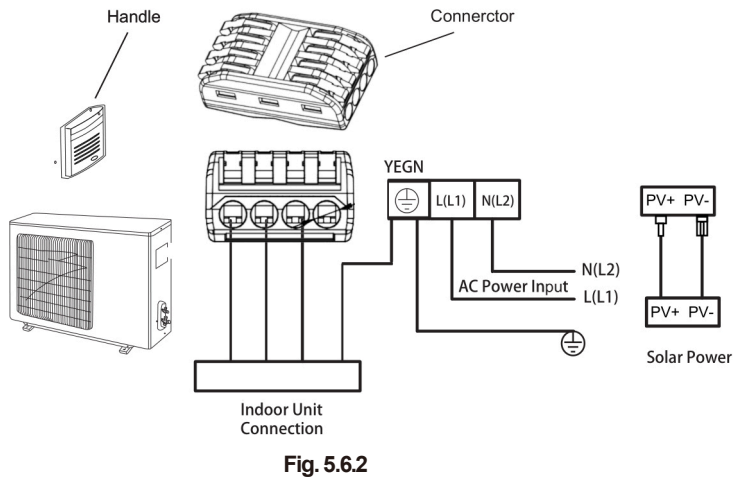
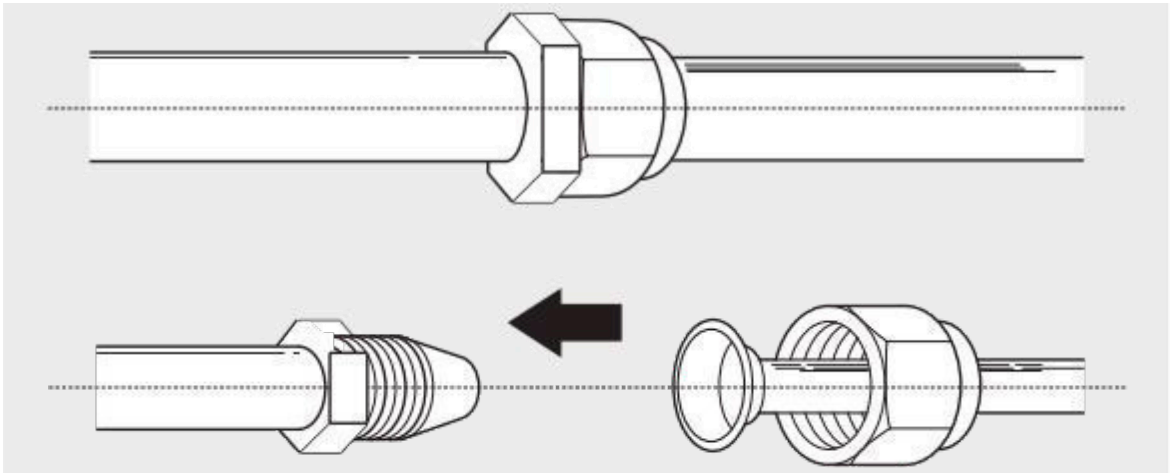

Diagram 2



Refrigerant Piping Connection

6



Note on Pipe Length

The length of refrigerant piping will affect the performance and energy efficiency of the unit. Nominal efficiency is tested on units with a pipe length of 5 meters (16 ft).

Refer to the table below for specifications on the maximum length and drop height of piping.

Maximum Length and Drop Height of Refrigerant Piping per Unit Model

Model	Capacity	Max. Length	Max. Drop Height
ECO-SPLIT	12,000 BTU/h \leq	15 m / 50 ft	5 m / 16 ft
	18,000 BTU/h \geq	20 m / 65 ft	10 m / 32ft

Connection Instructions – Refrigerant Piping

Step 1: Cut pipes

When preparing refrigerant pipes, take extra care to cut and flare them properly. This will ensure efficient operation and minimize the need for future maintenance.

1. Measure the distance between the indoor and outdoor units.
2. Use the piping kit accessory or pipes purchased locally

3. Using a pipe cutter, cut the pipe a little longer than the measured distance.
4. Make sure that the pipe is cut at a perfect 90° angle. Refer to **Fig. 6.1** for bad cut examples.

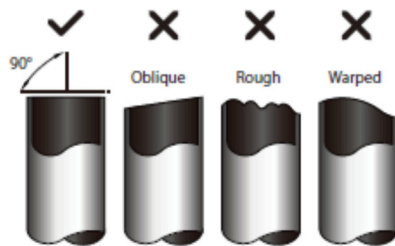

Fig. 6.1



DO NOT DEFORM PIPE WHILE CUTTING

Be extra careful not to damage, dent, or deform the pipe while cutting. This will drastically reduce the efficiency of the unit.

Step 2: Remove burrs

Burrs can affect the air-tight seal of refrigerant piping connection. They must be completely removed.

1. Hold the pipe at a downward angle to prevent burrs from falling into the pipe.
2. Using a reamer or deburring tool, remove all burrs from the cut section of the pipe.

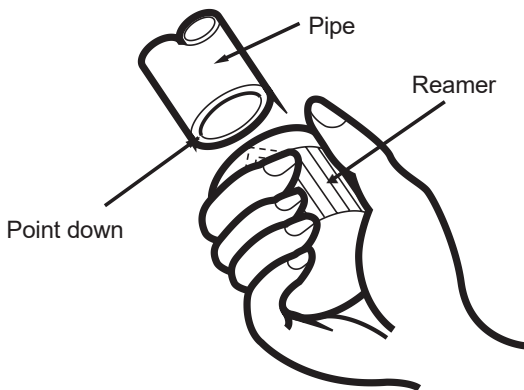

Fig. 6.2

Step 3: Flare pipe ends

Proper flaring is essential to achieve an airtight seal.

1. After removing burrs from cut pipe, seal the ends with PVC tape to prevent foreign materials from entering the pipe.
2. Sheath the pipe with insulating material.
3. Place flare nuts on both ends of pipe. Make sure they are facing in the right direction, because you can't put them on or change their direction after flaring. See Fig. 6.3.

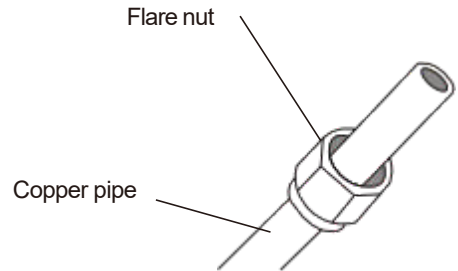

Fig. 6.3

4. Remove PVC tape from ends of pipe when ready to perform flaring work.
5. Clamp flare form on the end of the pipe. The end of the pipe must extend beyond the edge of the flare form in accordance with the dimensions shown in the table below.

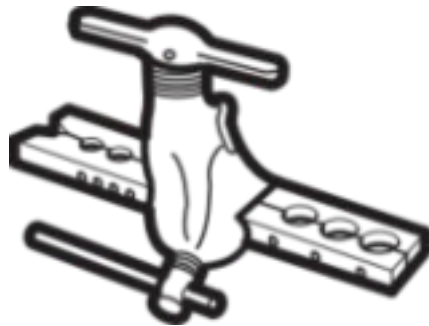

Fig. 6.4

PIPING EXTENSION BEYOND FLARE FORM

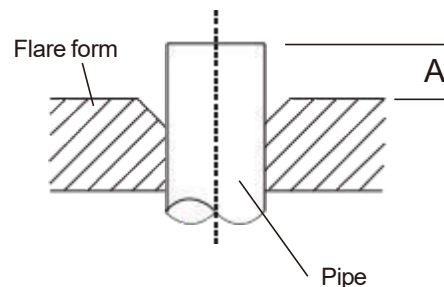

Fig. 6.5

6. Place flaring tool onto the form.
7. Turn the handle of the flaring tool clockwise until the pipe is fully flared.
8. Remove the flaring tool and flare form, then inspect the end of the pipe for cracks and even flaring.

Step 4: Connect pipes

When connecting refrigerant pipes, be careful not to use excessive torque or to deform the piping in any way. You should first connect the low-pressure pipe, then the high-pressure pipe.

MINIMUM BEND RADIUS

When bending connective refrigerant piping, the minimum bending radius is 10cm. See Fig 5.6 .

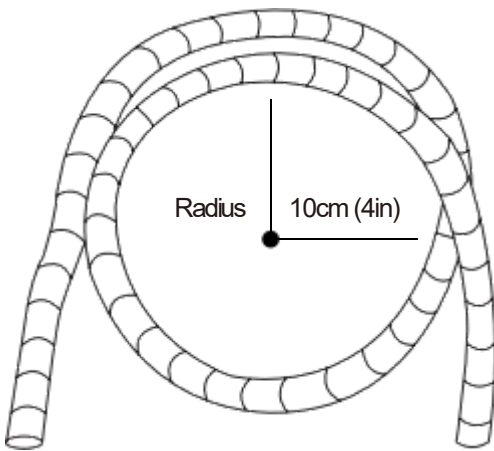

Fig. 6.6

Instructions for Connecting Piping to Indoor Unit

1. Align the center of the two pipes that you will connect. See Fig. 6.7 .

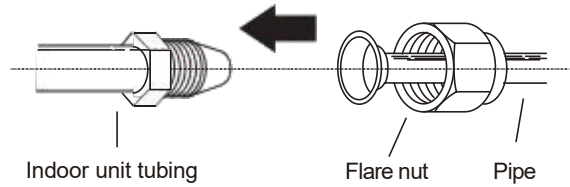

Fig. 6.7

2. Tighten the flare nut as tightly as possible by hand.
3. Using a spanner, grip the nut on the unit tubing.
4. While firmly gripping the nut on the unit tubing, use a torque wrench to tighten the flare nut according to the torque values in the **Torque Requirements** table below. Loosen the flaring nut slightly, then tighten again.

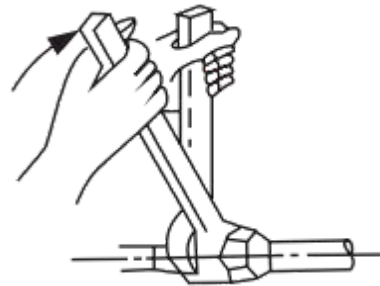

Fig. 6.8

TORQUE REQUIREMENTS

Outer Diameter of Pipe (mm)	Tightening Torque (N·m)
Ø 6.35 mm 1/4"	15-20
Ø 9.52 mm 3/8"	31-42

Refrigerant Piping Connection

! DO NOT USE EXCESSIVE TORQUE

Excessive force can break the nut or damage the refrigerant piping. Max. torque must not exceed torque requirements shown in the table above.

Instructions for Connecting Piping to Outdoor Unit

1. Remove protective caps from ends of valves.
2. Align flared pipe end with each valve, and tighten the flare nut as tightly as possible by hand.
3. Using a spanner, grip the body of the valve. Do not grip the nut that seals the service valve. (See **Fig. 6.10**)

USE SPANNER TO GRIP MAIN BODY OF VALVE

Torque from tightening the flare nut can snap off other parts of valve.

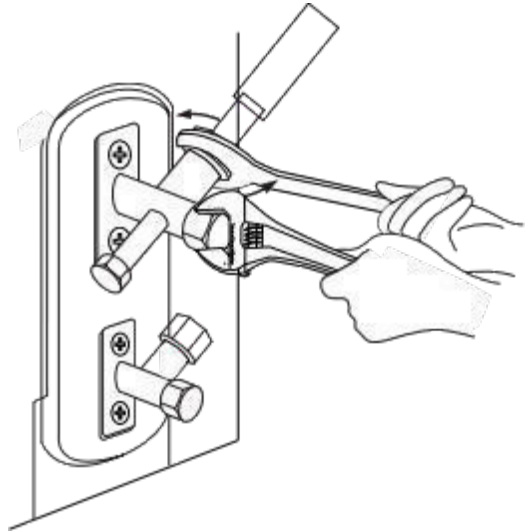
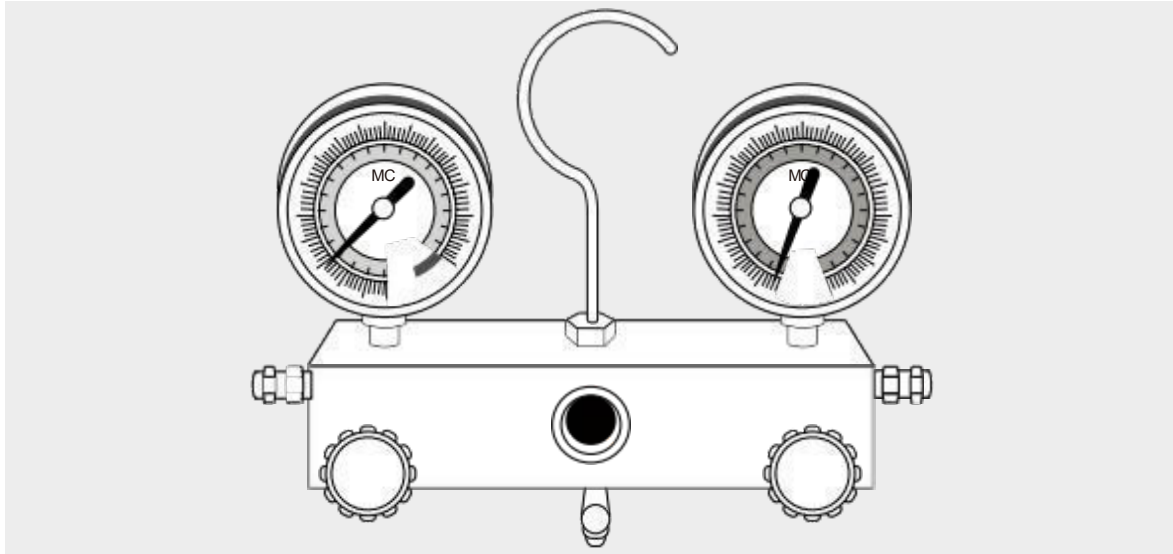

Fig. 6.10

5. While firmly gripping the body of the valve, use a torque wrench to tighten the flare nut according to the correct torque values.
6. Loosen the flaring nut slightly, and then tighten again.
7. Repeat Steps 3 to 6 for the remaining pipe.



Preparations and Precautions

Air and foreign matter in the refrigerant circuit can cause abnormal rises in pressure, which can damage the air conditioner, reduce its efficiency, and cause injury. Use a vacuum pump and manifold gauge to evacuate the refrigerant circuit, removing any non-condensable gas and moisture from the system.

Evacuation should be performed upon initial installation and when unit is relocated.

BEFORE PERFORMING EVACUATION

Check to make sure that both high-pressure and low-pressure pipes between the indoor and outdoor units are connected properly in accordance with the Refrigerant Piping Connection section of this manual.

Check to make sure all wiring is connected properly.

Evacuation Instructions

Before using the manifold gauge and vacuum pump, read their operation manuals to familiarize yourself with how to use them properly.

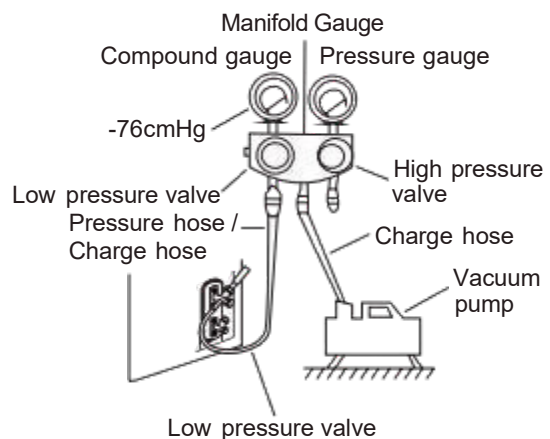

Fig. 7.1

1. Connect the charge hose of the manifold gauge to service port on the outdoor unit's low pressure valve.
2. Connect another charge hose from the manifold gauge to the vacuum pump.

3. Open the Low Pressure side of the manifold gauge. Keep the High Pressure side closed. Make sure to open the larger pipe. Opening the smaller one by mistake can cause refrigerant to escape.
4. Turn on the vacuum pump to evacuate the system.
5. Run the vacuum for at least 15 minutes, or until the Compound Meter reads -76cmHG (-10⁵ Pa).
6. Close the Low Pressure side of the manifold gauge, and turn off the vacuum pump.
7. Wait for 5 minutes, then check that there has been no change in system pressure.
8. If there is a change in system pressure, refer to Gas Leak Check section for information on how to check for leaks. If there is no change in system pressure, unscrew the cap from the packed valve (high pressure valve).
9. Insert hexagonal wrench into the packed valve (high pressure valve) and open the valve by turning the wrench in a 1/4 counterclockwise turn. Listen for gas to exit the system, then close the valve after 5 seconds.
10. Watch the Pressure Gauge for one minute to make sure that there is no change in pressure. The Pressure Gauge should read slightly higher than atmospheric pressure.

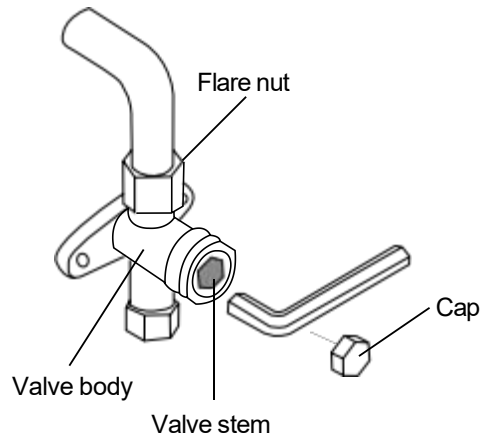

Fig. 7.2

11. Remove the charge hose from the service port.
12. Using hexagonal wrench, fully open both the high pressure and low pressure valves.
13. Tighten valve caps on all three valves (service port, high pressure, low pressure) by hand. You may tighten it further using a torque wrench if needed.

! OPEN VALVE STEMS GENTLY

When opening valve stems, turn the hexagonal wrench until it hits against the stopper. Do not try to force the valve to open further.

Note on Adding Refrigerant

Some systems require additional charging depending on pipe lengths. The standard pipe length varies according to local regulations. The additional refrigerant to be charged can be calculated using the following formula:

ADDITIONAL REFRIGERANT PER PIPE LENGTH

Connective Pipe Length (m)	Air Purging Method	Additional Refrigerant	
< Standard pipe length	Vacuum Pump	N/A	
< Standard pipe length (5m/16.4ft)	Vacuum Pump	$12000\text{BTU} \leq$ R32 (Pipe length – standard length) x 30g/m (Pipe length – standard length) x 0.32oz/ft	$18,000\text{BTU} \geq$ R32 (Pipe length – standard length) x 50g/m (Pipe length – standard length) x 0.53oz/ft

! CAUTION

DO NOT mix refrigerant types.

Electrical and Gas Leak Checks

8

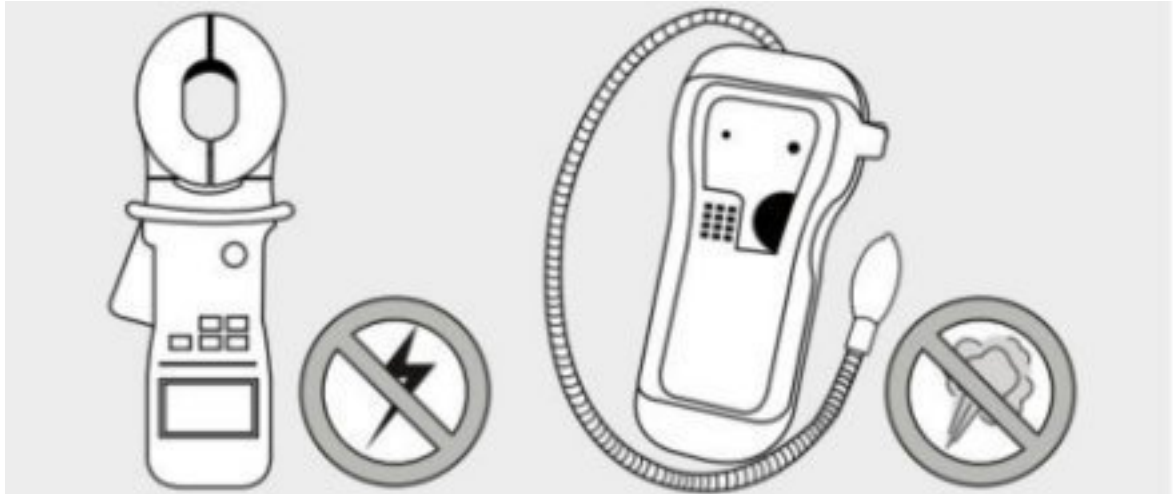

Electrical Safety Checks

After installation, confirm that all electrical wiring is installed in accordance with local and national regulations, and according to the Installation Manual.

BEFORE TEST RUN

Check Grounding Work

Measure grounding resistance by visual detection and with grounding resistance tester. Grounding resistance must be less than 4Ω .

Note : This may not be required for some locations in the US.

DURING TEST RUN

Check for Electrical Leakage

During the **Test Run**, use an electroprobe and multimeter to perform a comprehensive electrical leakage test.

If electrical leakage is detected, turn off the unit immediately and call a licensed electrician to find and resolve the cause of the leakage.

Note : This may not be required for some locations in the US.

WARNING— RISK OF ELECTRIC SHOCK

ALL WIRING MUST COMPLY WITH LOCAL AND NATIONAL ELECTRICAL CODES, AND MUST BE INSTALLED BY A LICENSED ELECTRICIAN.

Gas Leak Checks

There are two different methods to check for gas leaks.

Soap and Water Method

Using a soft brush, apply soapy water or liquid detergent to all pipe connection points on the indoor unit and outdoor unit. The presence of bubbles indicates a leak.

Leak Detector Method

If using leak detector, refer to the device's operation manual for proper usage instructions.

AFTER PERFORMING GAS LEAK CHECKS

After confirming that the all pipe connection points **DO NOT** leak, replace the valve cover on the outside unit.

Installation of the Solar Photovoltaic System

9

This manual contains information regarding the installation and safe handling of solar photovoltaic module. All instructions should be read and understood before attempting to install. If there is any question, please contact Ecosolaris support department for further explanation. The installer should conform to all the safety precautions listed in this guide when installing the module. Local codes should also be followed in such installations.

This manual describes several typical systems of solar photovoltaic, but does not involve the specific structures and installation procedures of the installation. Please consult the supplier for the information of the following assemblies:

1. The specifications of solar photovoltaic system;
2. Cable material;
3. Connecting components;
4. Bracket and support;
5. Supporting parts.

Keep this guide in a safe place for further reference (care and maintenance) and in case of sale or disposal of the module at the end of its service life.

General Requirements

- * Installation should be performed only by qualified persons, who are familiar with the mechanical and electrical requirement of installing solar photovoltaic system.
- * All modules come with a permanently attached junction box and #10AWG terminated in Multi-Contact (MC4) PV-KBT4 (female) or PV-KST4 (male) connectors.
- * The installer should assume the risk of all injury that might occur during installation, including, without limitation, the risk of electric shock.
- * The solar photovoltaic power system must comply with the specifications outlined in the table on page 7, "System Configuration & Electrical Specifications."

- * One individual solar module generates DC voltage greater than 30 V when exposed to direct sunlight. Contact with a DC voltage of 30V or more is potentially hazardous. Electrical joints such as the wire terminal will cause sparks, burning or deadly electric shock. Do not touch such terminals directly under any circumstances.

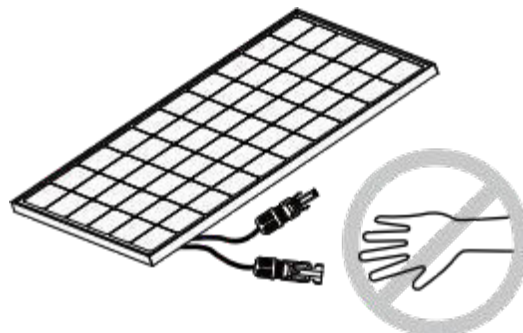

Fig. 9.1

- * Disconnecting wires from a photovoltaic module that is exposed to sunlight, may result in an electric shock. Such arcs burns, combustion and may otherwise create problems. Therefore, be extremely careful!

- * Photovoltaic solar modules convert light energy to direct-current electrical energy. They are designed for outdoor use. Solar modules can be ground, roof, vehicles, or boat roof mounted. Proper design of support structures is the responsibility of the system designer and installer. Proper use of mounting holes is suggested in the following paragraph.
- * Do not attempt to disassemble the module, and do not remove any nameplates or components attached.

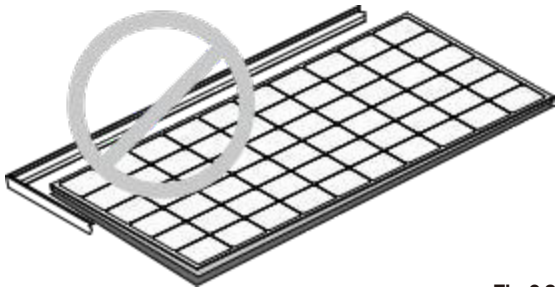

Fig. 9.2

- * Do not apply paint or adhesive to module top surface.

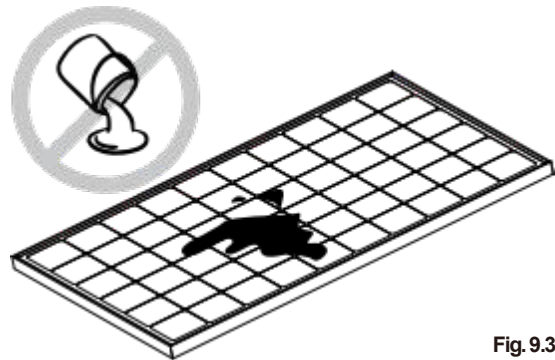

Fig. 9.3

- * Do not use mirrors or other magnifiers to concentrate sunlight on the module artificially.

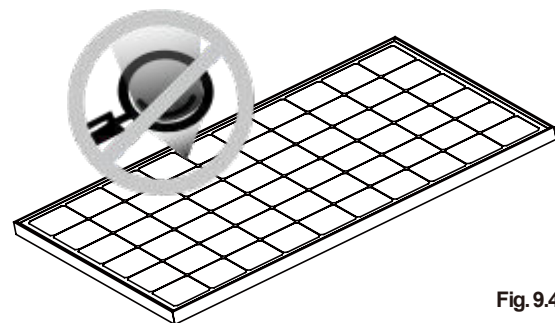

Fig. 9.4

- * When installing the system, abide with all local, regional and national statutory regulations.
- * Obtain a building permit where necessary. Abide with any local and national regulations when mounting on vehicles or boats.



SAFETY PRECAUTION FOR INSTALLATION SOLAR PHOTOVOLTAIC SYSTEM

- * When installing the solar modules or repairing the air conditioner, ensure the circuit breaker between solar panel and the outdoor unit is the "OFF" state (push the switch to "OFF" position).

During normal operation, the circuit breaker should be in the "ON" state (push the switch to "ON" position).

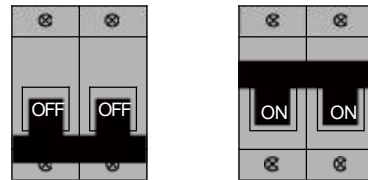

Fig. 9.5

- * Solar modules generate electrical energy when light strikes their front surface, producing a DC voltage that typically exceeds 30V. Modules must be connected in series (see Fig. 9.6), where the total voltage equals the sum of each module's voltage. They should not be connected in parallel, as this configuration increases current instead of voltage and is not compatible with the system's requirements.

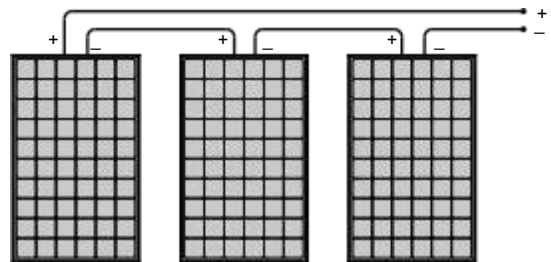

Fig. 9.6

- * Keep children well away from the system while transporting and installing mechanical and electrical components.

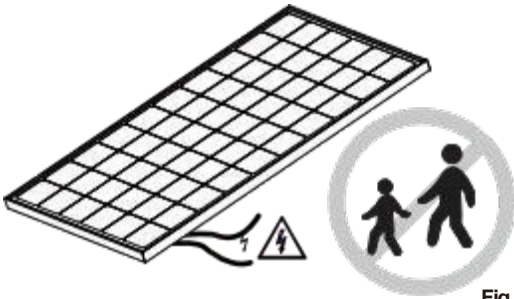

Fig. 9.7

- * Use only insulated tools that are approved for working on electrical installations.

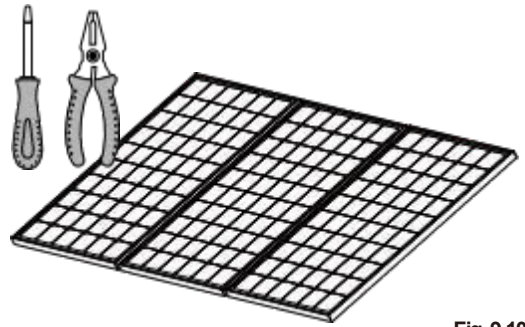

Fig. 9.10

- * Completely cover the module with an opaque material during installation to keep electricity from being generated. Do not touch the components or the end of live wires. However, if appropriate protection has been taken during the operation according to the local safety regulations, the above requirement is unnecessary.

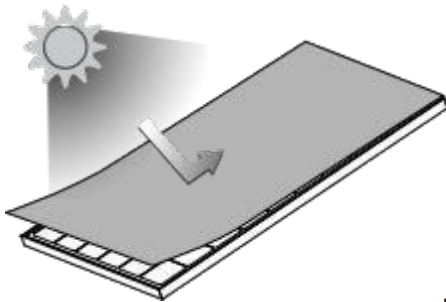

Fig. 9.8

- * When performing installation in dry conditions, please ensure the tools used in the dry.

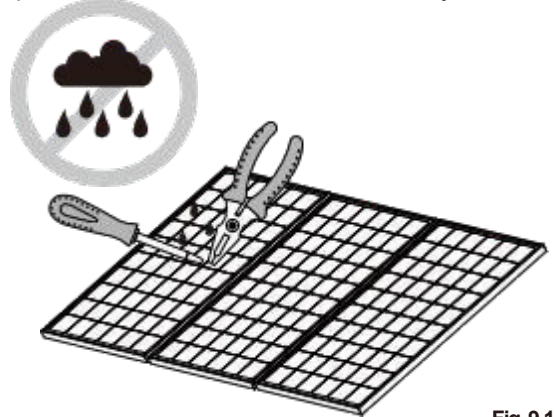

Fig. 9.11

- * Do not wear metallic rings, watchbands, ear, nose, lip rings or other metallic devices while installing or troubleshooting photovoltaic systems.

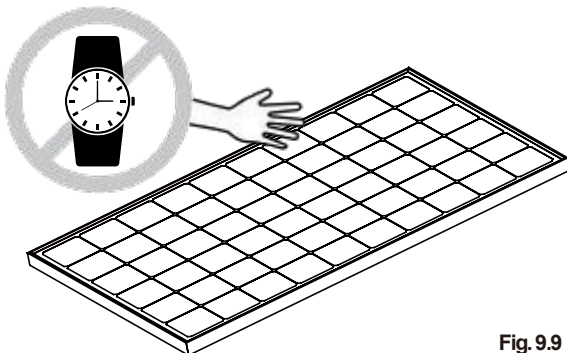

Fig. 9.9

- * Abide by the safety regulations for all other components used in the system, including wiring and cables, connectors, charge controllers, inverters, storage batteries and rechargeable batteries, etc.

Use only equipment, connectors, wiring and support frames suitable for use in a solar electric system. Always use the same type of module within a particular photovoltaic system.

- * The module frame must be properly grounded. The grounding wire must be properly fastened to the module frame to assure good electrical contact. Use the recommended type, or an equivalent, connector for this wire.

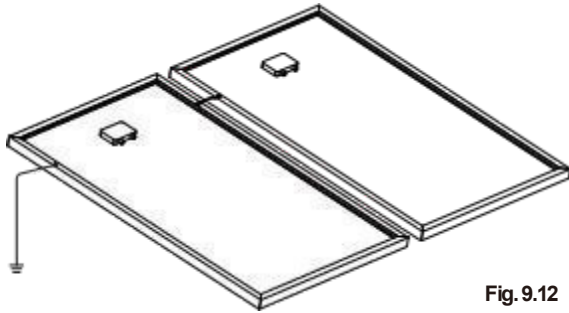

Fig. 9.12

- * Under normal outdoor conditions, the module will produce current and voltages that are different from those listed in the datasheet. Data sheet values are values expected at standard test conditions. Accordingly, during system design, values of short-circuit current (I_{sc}) and open circuit voltage (V_{oc}) marked on UL series modules should be multiplied by a factor of 1.25 when determining component voltage ratings, conductor ampacity, fuse size and size of controls connected to the module or system output.
- * The hole in the back of the module frame is used to drain the water, which should not be blocked.

Mechanical Installation

1. Selecting installation place

- * Select a suitable place for installation of the module. The module should not be shaded at anytime of the day.
- * The module should be facing due south in northern latitudes and due north in southern latitudes for best power generation.
- * For detailed information on the best elevation tilt angle for the installation, please consult with the solar photovoltaic system supplier.

- * Do not mount module near the place where the flammable gas may be generated or collected.

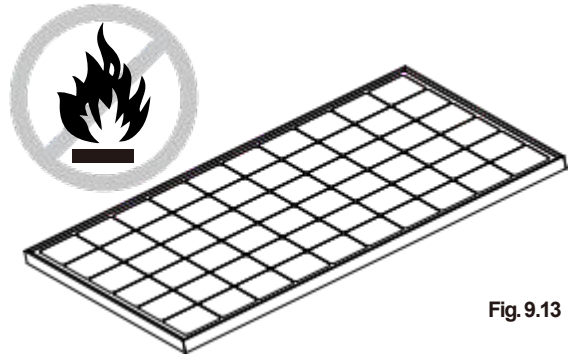

Fig. 9.13

2. Selecting the proper support frame

- * Always observe the instructions and safety precautions included with the support frame to be used with the module.
- * Never attempt to drill holes in the glass surface of the module. It will void the warranty.
- * Do not drill additional mounting holes in the frame of the module. It will void the warranty.

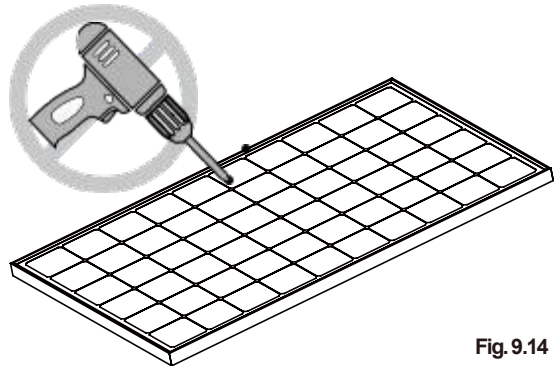

Fig. 9.14

- * Modules must be securely attached to the mounting structure using four mounting points for normal installation. If additional wind or snow loads are considered for the installation, additional mounting points should also be used.
- * The support frame must be made of durable, corrosion-resistant and UV-resistant material.
- * The heat expansion and cold contraction of the support frame should have no effect on to its usage and performance.

3. Ground mounting

Select the height of the mounting system to prevent the lowest edge of the module from being covered by snow for a long time in winter in areas that experience heavy snowfalls. In addition, assure the lowest portion of the module is placed high enough so that it is not shaded by plants or trees or damaged by sand and stone driven by wind.

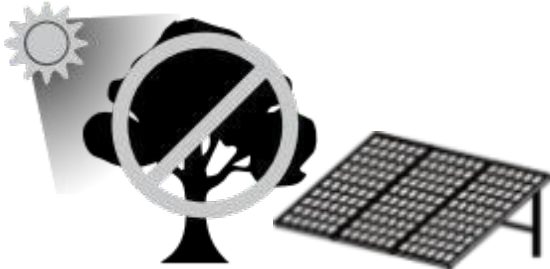

Fig. 9.15

- * When installing module on a roof, ensure that the roof construction is suitable. In addition, any roof penetration required to mount the module must be properly sealed to prevent leaks. In some cases, a special support frame may be necessary.
- * The roof installation of solar modules may affect the fireproofing the house construction, so it is necessary to use an earth ground fault circuit breaker. Any improper installation may cause accidental injuries.

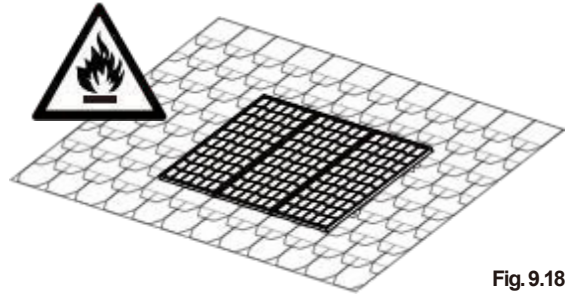

Fig. 9.18

4. Roof mounting

* When installing a module on a roof or building, ensure that it is securely fastened and cannot fall because of wind or snow loads.

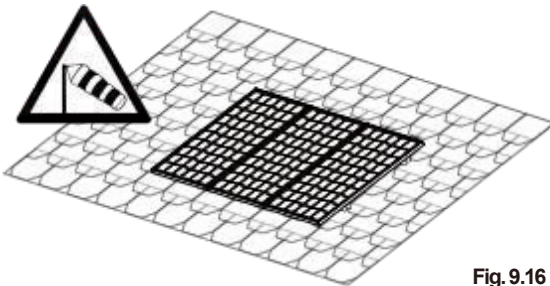

Fig. 9.16

- * When installing the module on a roof or building, do so in calm wind. Installing a module during strong wind may cause accidents.

5. Pole mounting

When installing a module on a pole, choose a pole and module mounting structure that will withstand anticipated wind for the area. The pole must have a solid foundation.

* Provide adequate ventilation under a module for cooling (5cm minimum air space between module and mounting surface).

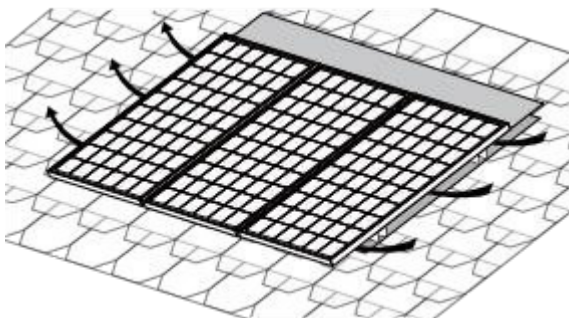

Fig. 9.17

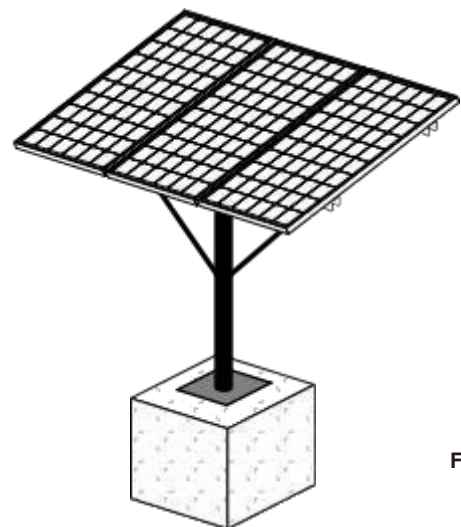

Fig. 9.19

- * Module mounting must use the pre-drilled mounting holes in the frame.
- * The most common mounting is achieved by mounting the module using the four symmetry points closed to the inner side of the module frame.
- * If excessive wind or snow load are expected, all eight mounting holes must be used.
- * If you want to install the module without using the pre-drilled mounting holes in the frame, please consult with the supplier.
- * Do not install in the rainy weather. It may cause insulation failure due to moisture, and there is a risk of electric shock.

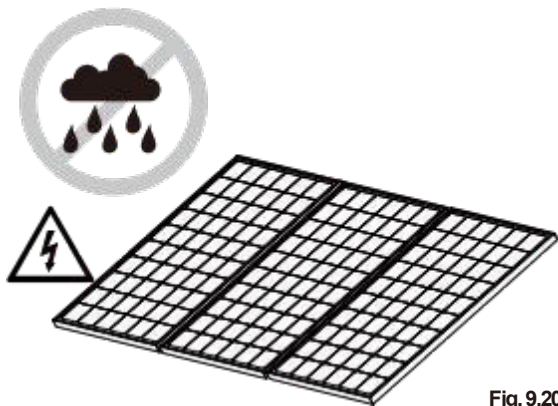

Fig. 9.20

- * Do not attempt to lift the module by grasping the modules junction box while moving.

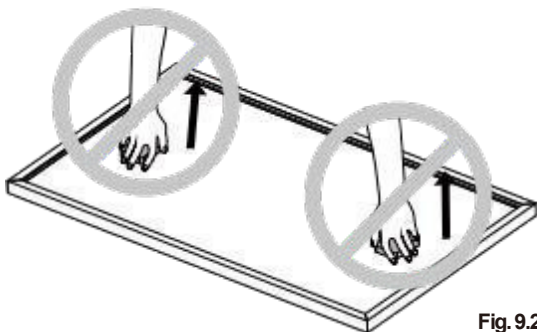

Fig. 9.21

- * Do not stand or step on module.

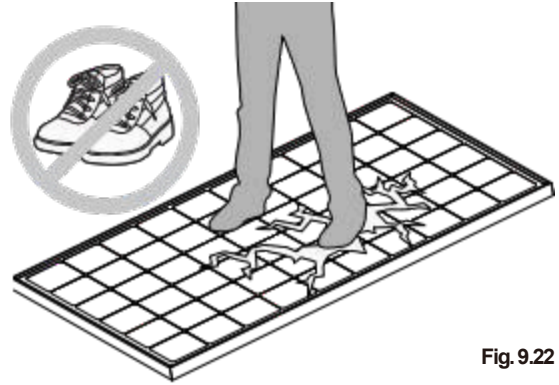

Fig. 9.22

- * Do not throw the module or drop anything on the module. To avoid glass breakage, do not place any heavy objects on the module.

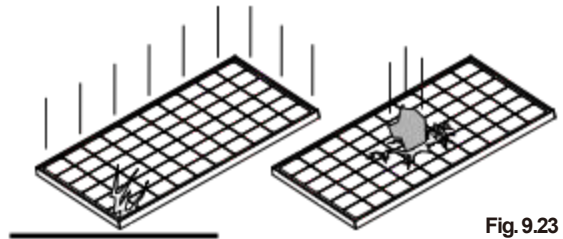

Fig. 9.23

- * Do not set the module down hard on any surface.
- * Inappropriate transportation and installation may break the glass of the module.

Electrical Installation

1. General installation

- * Do not use modules of different configurations in the same system.
- * The solar photovoltaic array consists of modules connected in series. Modules in series can increase the output voltage of the solar PV system, especially for the applications requiring high voltage. If modules are connected in series, the total voltage should be less than 380V.
- * If modules used in the solar photovoltaic system

are not the specified brand of the manufacturer, it must comply with the electrical requirement. The cross section area of cable and the capacity of connector must be selected to suit the maximum system short circuit current. Otherwise, the cable and the connector will be overheated under large current.

Any hardware used must be compatible with the mounting structure material to avoid galvanic corrosion. MC4 connector is the recommended connector and the recommended system wires size is AWG10(4sq mm).

Installation sketch as figure below.

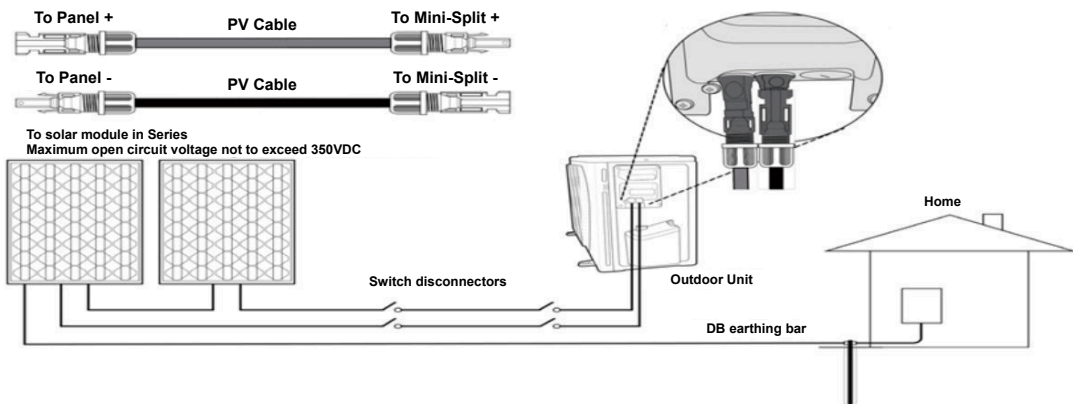

- * The PV-wire should be single-pole, double insulated solar cable, the length of which is due to the distance from PV modules to outdoor unit of air conditioner. The recommended conductor cross section is AWG10(4sq mm), and it should accord with UL4703.
- * The MC-4 Connectors should be assembled to the PV-wires on both side, and please follow Fig. 9.25 to make the MC4 connector.

If you want to connect the photovoltaic modules by using the cables purchased by yourself, the following requirements must be complied:

- * Cable installation should comply with all local regional and national regulations.
- * In some countries, an individual circuit breaker used between the solar panel and air conditioner must be installed. So select a circuit breaker in accordance with local regulations.
- * Cable installation needs to distinguish the positive pole and negative pole. Reversed connection may cause permanent damage to the air conditioner.
- * Use qualified photovoltaic cables only.

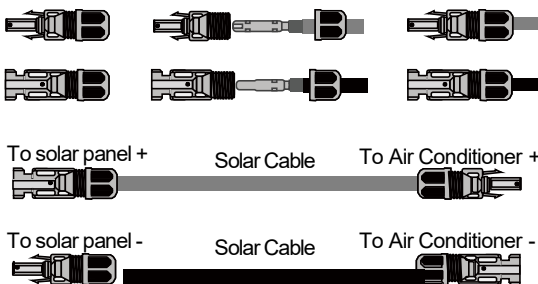

Fig. 9.25

- * The cable can resist UV rays and climate of rapid change.
- * The rated voltage of the cable is more than 600V.
- * The cross-section area of the cable depends on the maximum short circuit current and the length of wire.
- * Be very careful when installing the cable at extremely low temperature.
- * Recommend to use the cable of cross section area of AWG10(4sq mm) or greater, and the wire should be as short as possible to reduce the energy consumption.
- * Cables must be securely fastened on the support frame to avoid wireslack.

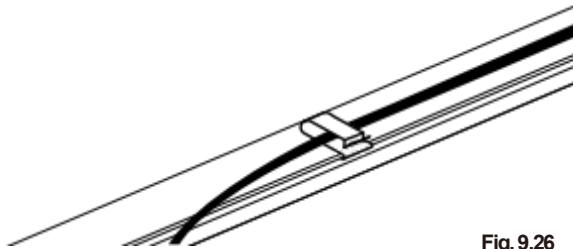

Fig. 9.26

- * Do not place the cable on the sharp edge of things. And pay attention to the minimum bending radius of the wire.

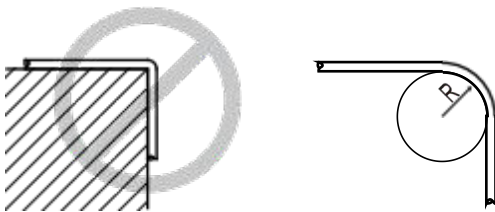

Fig. 9.27

- * Do not unplug the connector when power is on.

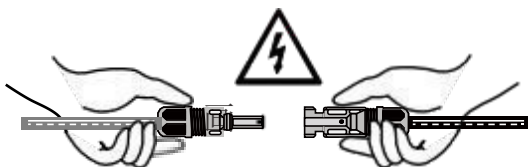

Fig. 9.28

- * The protecting sheath must be used on the cable if there is a possibility of children or animals touch it easily.

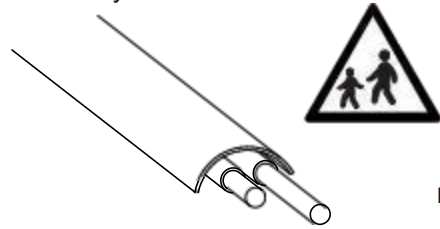

Fig. 9.29

- * The manufacturer of the solar photovoltaic system can supply cables suitable for use in a solar electric system.

If you want to use the connector purchased by yourself, the following requirements must be complied:

- * Use only connector special designed for solar electric system.
- * Use the recommended or specified tools when install the connectors.
- * Do not unplug the connectors when the power is on.
- * The connector suitable for the solar photovoltaic system can obtain from the manufacturer.

Electrical Connection

- * Completely cover the module with an opaque material during mechanical installation and electrical installations.
- * Protect the cables from being damaged.
- * Ground mounting must abide with all local regulations.

Grounding

- * The module frame must be properly grounded. The grounding wire must be fastened to the module frame properly to assure good electrical contact.

- * If the support frame is made of metal, the surface of the frame must be electroplated and have excellent conductivity. The grounding wire must be fastened to the support frame properly.
- * There are two pre-drilled mounting holes in the frame, used to install the grounding cable. Each module should connect with the grounding cable.
- * We recommend the closed lug when grounding. First insert the ground cable into the jack of the closed lug and weld, then insert the stainless steel bolt (M3) into the tab of the lug, the founding hole on the frame and finally a nut to

secure the entire assembly. The spring washer is required in order to prevent screw loosening and cause improper grounding.

- * The grounding resistance must be less than 10ohms.

Junction Box Installation

- * All modules come with a permanently attached junction box and provide with fitted cables.
- * The junction box do not need the customer to install, please contact the manufacturer if there is any problem with the module.

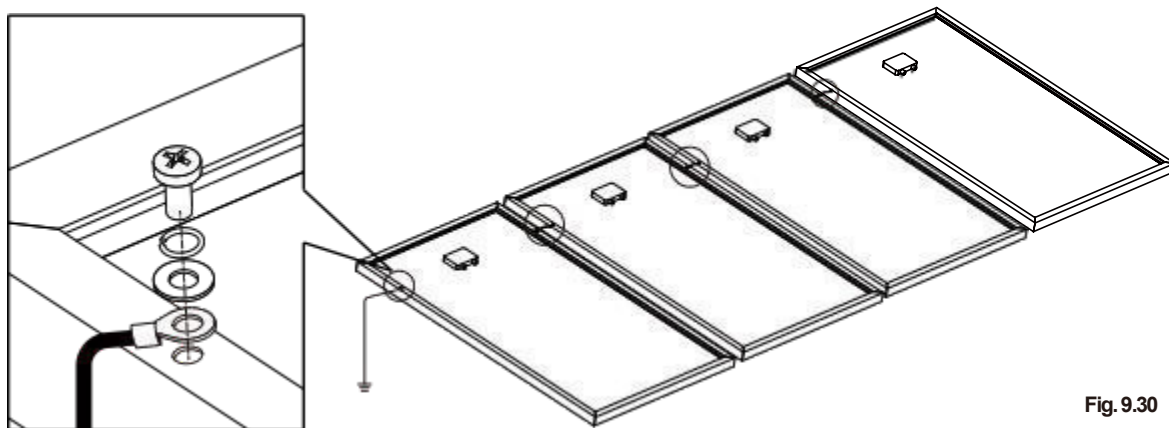

Fig. 9.30

DISCLAIMER OF LIABILITY

Because the use of this manual and the conditions or methods of installation, operation, use, and maintenance of the photovoltaic (PV) product are beyond our control, we do not assume any responsibility and expressly disclaim liability for any loss, damage, or expense arising from or in any way related to such installation, operation, use, or maintenance. The manufacturer accepts no responsibility for any infringement of patents or other third-party rights that may result from the use of the PV product. No license is granted, whether by implication, modification, or otherwise, under any patent or patent rights.

The information contained in this manual is based on the manufacturer's knowledge and experience and is believed to be accurate; however, such information—including but not limited to product specifications and recommendations—does not constitute a warranty, either expressed or implied.

We reserve the right to modify this manual, the PV product, its specifications, or any related product documentation at any time without prior notice.

GROUNDING PRINCIPALS

Equipment grounding provides protection from shock caused by a ground fault and is required for all PV systems by the National Electrical Code (NEC).

A ground fault occurs when a current-carrying conductor comes into contact with the frame or chassis of an appliance or an electrical box. A person who touches the frame or chassis of the faulty appliance will complete the circuit and receive a shock.

The frame or chassis is deliberately wired to a grounding electrode by an equipment grounding electrode conductor. The wire does not normally carry current except in the event of a ground fault. The grounding conductor must be continuous, connecting every non-current carrying metal part of the installation to ground. It must bond or connect to every metal electrical box, equipment chassis, and photovoltaic panel mounting. The grounding wire is never fused, switched, or interrupted in anyway. When metal conduit or armored cable is used, a separate equipment ground is not usually necessary since the conduit itself acts as the continuous conductor in lieu of the grounding wire. Grounding wires are still needed to connect appliance frames to the conduit.

1. Ground-fault protection

Roof-mounted DC PV arrays located on dwellings must be provided with DC ground-fault protection (NEC 2005, Article 690.5) Ground-fault protection isolates the grounded conductor (in DC, this is the negative wire) from ground, underground-fault conditions.

2. Size of equipment grounding conductor

The size of the equipment grounding wire can be as large as the current carrying conductors, both positive and negative wires, but not smaller than

specified in NEC 2005, table 250.122.

3. Four pieces solar panels grounding

Using min. 4 mm² solar cable between solar panels and air conditioner. A 30A DC circuit breaker between solar panels and air conditioner is recommended. Both solar panels and air conditioner side should do a good grounding.

Compatible MC4 solar connectors are used in both side of the solar cable. Please follow the positive and negative mark on the air conditioner.

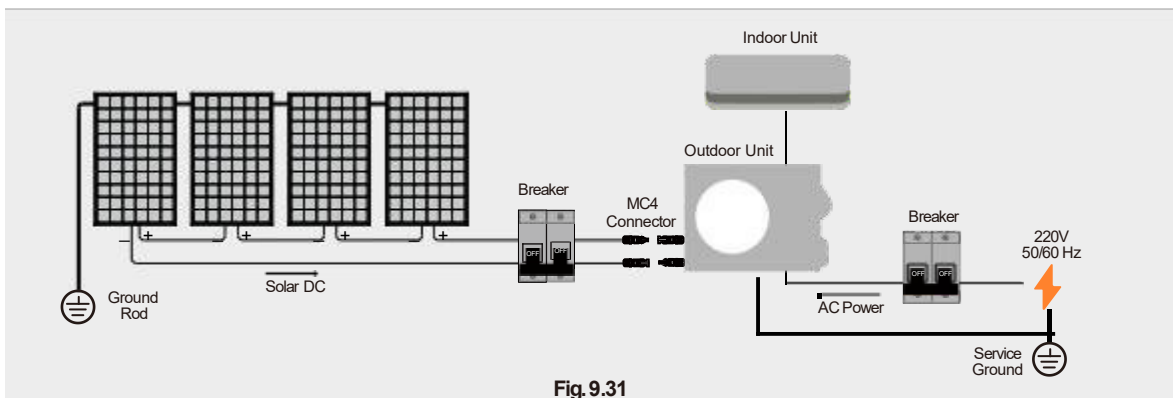

Test Run

10

Before Test Run

Only perform test run after you have completed the following steps:

- **Electrical Safety Checks** – Confirm that the unit's electrical system is safe and operating properly
- **Gas Leak Checks** – Check all flare nut connections and confirm that the system is not leaking
- Confirm that gas and liquid (high and low pressure) valves are fully open

Test Run Instructions

You should perform the **Test Run** for at least 30 minutes.

1. Connect power to the unit.
2. Press the **ON/OFF** button on the remote controller to turn it on.
3. Press the **MODE** button to scroll through the following functions, once at a time:
 - COOL – Select lowest possible temperature
 - HEAT – Select highest possible temperature
4. Let each function run for 5 minutes, and perform the following checks:

List of Checks to Perform	PASS (✓)	FAIL (×)	TEST RESULT
Solar array Voc test			
Solar array grounding fault test			
Solar array operating current test			
No electrical leakage			
Unit is properly grounded			
All electrical terminals properly covered			
Indoor and outdoor units are solidly installed			
All pipe connection points do not leak			
Water drains properly from drain hose			
All piping is properly insulated			
Unit performs COOL function properly			
Unit performs HEAT function properly			
Indoor unit louvers rotate properly			
Indoor unit responds to remote controller			

DOUBLE-CHECK PIPE CONNECTIONS

During operation, the pressure of the refrigerant circuit will increase. This may reveal leaks that were not present during your initial leak check. Take time during the Test Run to double-check that all refrigerant pipe connection points do not have leaks. Refer to **Gas Leak Check** section for instructions.

5. After the Test Run is successfully complete, and you confirm that all checkpoints in List of Checks to Perform have PASSED, do the following:
 - a. Using remote control, return unit to normal operating temperature.
 - b. Using insulation tape, wrap the indoor refrigerant pipe connections that you left uncovered during the indoor unit installation process.

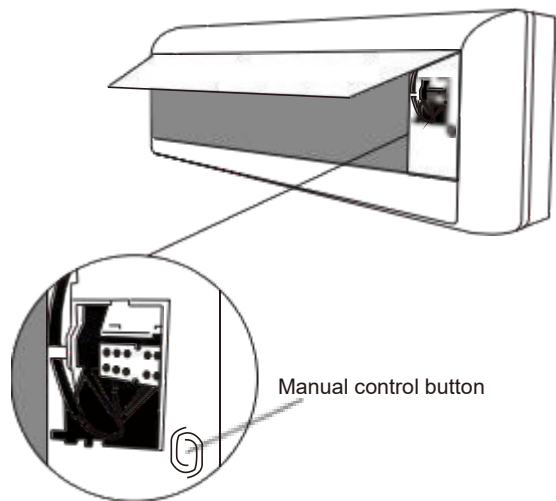

Fig. 10.1

IF AMBIENT TEMPERATURE IS BELOW 16°C (61°F)

You can't use the remote controller to turn on the COOL function when the ambient temperature is below 16°C. In this instance, you can use the **MANUAL CONTROL** button to test the COOL function.

1. Lift the front panel of the indoor unit, and raise it until it clicks in place.
2. The **MANUAL CONTROL** button is located on the right-hand side of the unit. Press it twice to select the COOL function. See **Fig 10.1**.
3. Perform Test Run as normal.

Table of revisions

11

Table of revisions			
Revision date	Version	Revisions	Revised by
12.2025	V2.02.01		CB, JR
05.2026	V2.02.02	VOC clarification, line set length adjustment, unit dimension correction, refrigerant charge clarification	CB, JR

Solar Cooling
By  **ECOSOLARIS**